



FRÄSSYSTEME

MILLING SYSTEMS

2023/2024



ERLEBEN SIE HORN
EXPLORE HORN

Erleben Sie HORN

Außergewöhnliche Ergebnisse sind immer die Verbindung aus dem optimalen Zerspanprozess und dem perfekten Werkzeug. Dafür kombiniert HORN Spitzentechnologie, Leistung und Zuverlässigkeit. Von der Einzelteil- bis zur Serienfertigung, bei Standard- oder Sonderanwendungen: Unsere Werkzeuge bieten Ihnen schnelle, wirtschaftliche und qualitativ hochwertige Lösungen. Bei der Wahl der individuellen Schnittparameter unterstützen Sie unsere Tabellen mit praxiserprobten Erfahrungswerten im jeweiligen Katalog. Nutzen Sie darüber hinaus das Fachwissen unserer Innen- und Außendienstmitarbeiter.

Nachhaltigkeit ist ein zentraler Bestandteil unserer Unternehmensphilosophie. Daher stehen bei uns Qualitätssicherung, Umweltschutz, Energieeffizienz und Sicherheit hinsichtlich unserer Produkte und unserer Produktion seit jeher im Fokus. Als leistungsfähiger und zuverlässiger Werkzeugpartner tragen wir dafür Sorge, dass Sie gemeinsam mit uns in eine innovative und wirtschaftliche Zukunft gehen.



Lothar Horn
Geschäftsführer
Paul Horn GmbH



Markus Horn
Geschäftsführer
Paul Horn GmbH



Matthias Rommel
Geschäftsführer
Paul Horn GmbH

Explore HORN

Exceptional results are always a combination of the optimum cutting process and the perfect tool. To achieve this, HORN combines advanced technology, performance and reliability. From single part to series production, for standard or special applications: Our tools offer you fast, economical, high quality solutions. To assist you when choosing cutting parameters, our tables in the respective catalogue provide proven empirical values. Take advantage of the expertise of our office staff and sales engineers.

Sustainability is a central part of our corporate philosophy. That is why we have always focused on quality assurance, environmental protection, energy efficiency and safety with regard to our products and our production. As an efficient and reliable tool partner, we make sure that you join us in an innovative and strong economic future.



Lothar Horn
CEO
Paul Horn GmbH

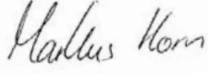

Markus Horn
CEO
Paul Horn GmbH



Matthias Rommel
CEO
Paul Horn GmbH

A	System DC Nut- und Gewindefräser Vollhartmetall System DC Solid Carbide Groove and Thread Milling Cutter		A
B	Nutfräsen (zirkular) Groove Milling by circular interpolation	M304/M306/M308/M311/ M116/M313/M328/M332/M335	B
	Plan- und Hochvorschubfräsen Face and High Feed Milling	M620	
C	Nutfräsen Groove Milling	M275	C
D	Nutfräsen Groove Milling	380/381	D
E	Nutfräsen Groove Milling	M101	E
F	Nutfräsen Groove Milling	382/383/M310	F
G	Gewindefräsen Thread Milling	M275/M306/M308/M311 M313/M328/M332/380	G
H	Technische Hinweise Nut- und Zirkularfräsen Technical Instructions Groove and Circular Milling		H
I	Verzahnungsbearbeitung Gear Machining		I
J	T-Nuten-Fräsen Milling of T-Slots	M311/M313/M328/M406 M409	J
K	Mehrkantschlagen Polygon Milling	M275/381	K
L	System DA / DAH Hochvorschubfräsen System DA / DAH High Feed Milling		L
M	Tangentialfräsen Tangential Milling	M406/M409/M610	M

- Alle Abmessungen sind in mm angegeben, sofern nicht anders vermerkt.
All dimensions in mm, unless otherwise noted
- Weitere Abmessungen und Ausführungen sind auf Anfrage erhältlich.
Further dimensions and versions are available on request.
- Das Anzugsmoment der Schrauben finden Sie im Kapitel "Technische Hinweise".
For torque specification of the screw, please see "Technical Instructions".
- Alle Hartmetall-Fräaserschäfte mit beschädigter Schneidplattenaufnahme können von unserem Reparaturservice instand gesetzt werden.
All carbide milling shanks with damaged seating can be repaired by HORN.
- Lieferzeiten / delivery times
 - ▲ ab Lager / on stock
 - △ 4 Wochen / 4 weeks
- Einsatz für Werkstoffgruppen / Use for material groups
 - empfohlen / recommended
 - bedingt einsetzbar / alternative recommended
 - nicht geeignet / not suitable

Die HORN-Trennstellencodierung - wofür wird sie benötigt?

Die Trennstellencodierung stellt sicher, dass Sie immer die zueinander passenden Werkzeuge finden und wird bei Werkzeughaltern und bei Schneidplatten ausgewiesen. Wenn die Codes übereinstimmen, kann die Schneidplatte im entsprechenden Werkzeughalter verwendet werden.

Das gilt auch für unser modulares Haltersystem, hier gibt die Trennstellencodierung die Schnittstelle zwischen Grundhalter und Kassette an.

The HORN connection interface code - what is it needed for?

The connection interface code ensures that you will always find the appropriate tools and is shown on toolholders and inserts. If the codes match, the insert can be used in the corresponding toolholder.

This also applies to our modular holder system, where the connection code indicates the interface between the holder and the cassette.

HORN-Trennstellencodes und mögliche Kombinationen:

HORN connection interface codes and possible combinations:

HIS = Plattensitzgröße / Insert seat

HWS = Trennstelle Werkstückseitig / Interface workpiece side

HMS = Trennstelle Maschinenseitig / Interface machine side

HIS	↔	HWS
HMS	↔	HWS

Beispiel Schneidplatte

Example insert

Bestellnummer Part number	Ds	Nw	w	s	s ₁	t _{max}	Z	HIS	TA45
306.0050.10.00	9,7	0,5	0,57	3,4	3,2	0,85	3	306060R	▲

Beispiel Klemmhalter

Example toolholder

Bestellnummer Part number	d	l ₁	Form	HWS
M306.0707.03A	7,5	100	A	306060R • 306060L

N Technische Hinweise, Zubehör
Technical Instructions, Additional Equipment

INDEX

Übersicht Anwendungen

Overview Application

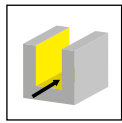

Nutfräsen
Groove milling



Vollradiusnut fräsen
Full radius groove milling

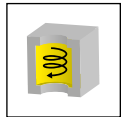

Zirkularnut
Circular groove



Innennut fräsen
Internal groove milling



Seegerringnut
Circlip groove

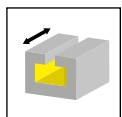

T-Nuten DIN650
T-Slots DIN650

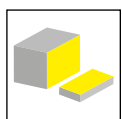

Trennfräsen
Slot milling

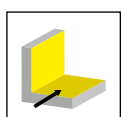

Eckfräsen
Corner milling

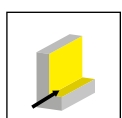

Besäumen
Trimming

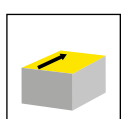

Planfräsen
Face milling

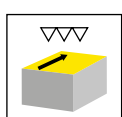

Schlichtfräsen
Finishing

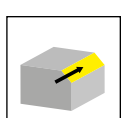

Fasen
Chamfering

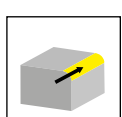

Radius fräsen
Radius milling

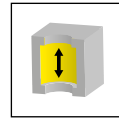

Bohrung fräsen
Bore milling

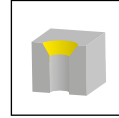

Fase fräsen
Chamfer milling

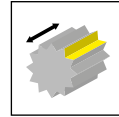

Verzahnung fräsen
Gear milling

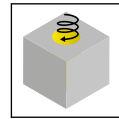

Zirkulareintauchen
Circular plunging

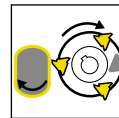

Mehrkantschlagen
Polygon milling

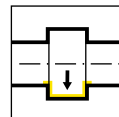

Einstechen innen
Internal grooving

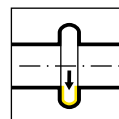

Einstechen innen Vollradius
Internal grooving full radius



Ausdrehen und Fasen innen
Internal boring and grooving chamfer

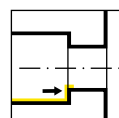

Rückwärtsdrehen innen
Internal back turning

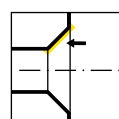

Fasen innen
Internal chamfering

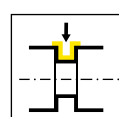

Einstechen außen
External grooving

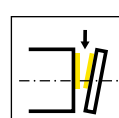

Abstechen
Parting off

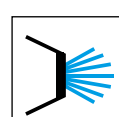

Innenkühlung
Internal coolant

Übersicht Anwendungen

Overview Application

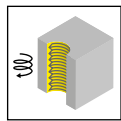

Gewinde fräsen innen
Thread milling internal

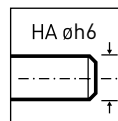

Schaftform
Shank form



Gewinde Teilprofil
Partial profile thread

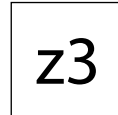

Zähnezahlen
Numbers of teeth



Gewinde Vollprofil
Full profile thread

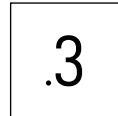

Geometrie .3
Geometry

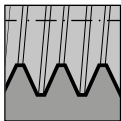

Gewinde innen
Internal thread

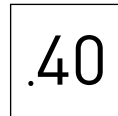

Geometrie .40 für Aluminium
Geometry .40 for aluminium

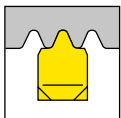

Gewinde Whitworth
Whitworth thread

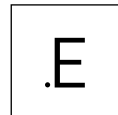

Geometrie .E
Geometry

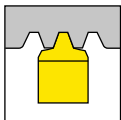

Trapezgewinde
Trapezoidal thread

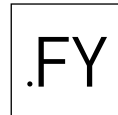

Geometrie .FY
Geometry



BSW
BSF

Whitworth-Rohrgewinde
Whitworth pipe thread



NPT
NPTF

National pipe thread



45°

Anstellwinkel 45°
Approach angle 45°

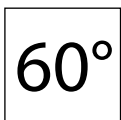

60°

Gewinde metrisch
Metric ISO thread
Anstellwinkel 60° (Kapitel Tangentialfräsen)
Approach angle 60° (Chapter Tangential Milling)



UN

Unified-Gewinde
Unified thread

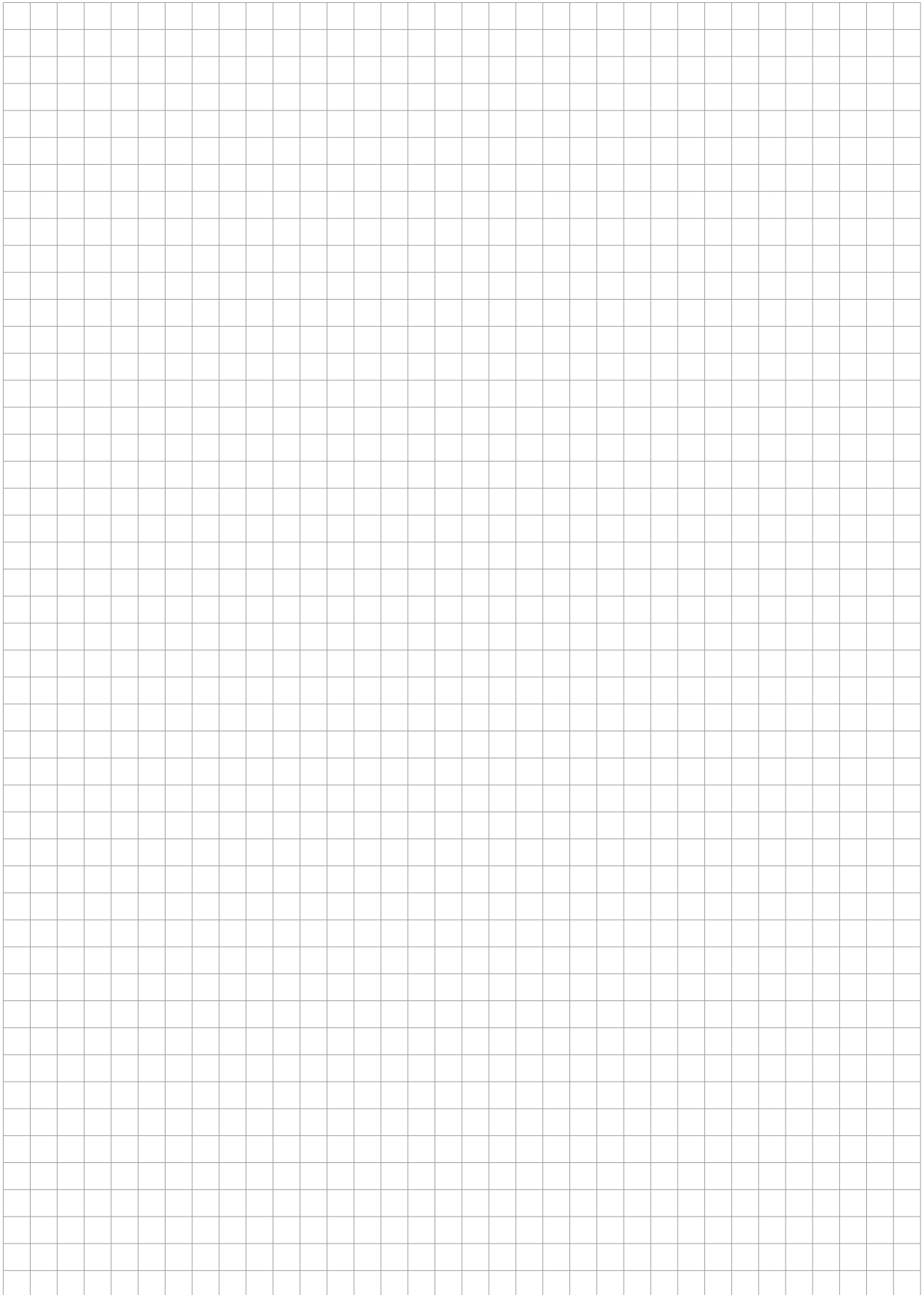

DC



Vollhartmetall-Schaftfräser System DC

- Gewindefräsen Teilprofil
- Gewindefräsen Vollprofil
- Nutfräsen
- Fasfräsen

Solid Carbide End Mills System DC

- Thread milling partial profile
- Thread milling full profile
- Groove milling
- Chamfer milling

Gewindefräser
Thread Milling Cutter
DCG



Seite/Page
13-14



Seite/Page
15



Seite/Page
16



Seite/Page
17

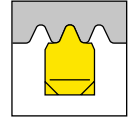

Seite/Page
18

Nutfräser
Groove milling cutter
DCR/DCN/DCX

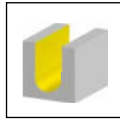

Seite/Page
19

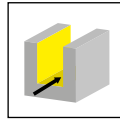

Seite/Page
20-21

Fasfräser
Chamfer Milling Cutter
DCF

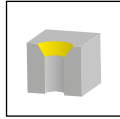

Seite/Page
22

Schnittdaten
Cutting data

Seite/Page
23-25



z3

60°

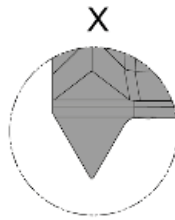
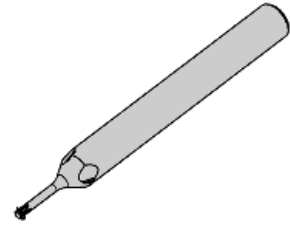
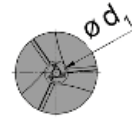
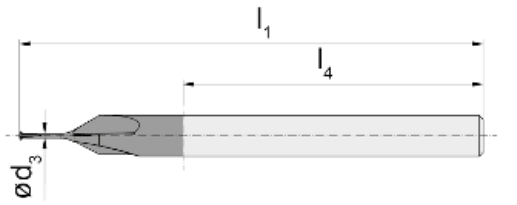

HM-Sorten
Carbide grades

▲ ab Lager
on stock

Δ 4 Wochen
4 weeks

Bestellnummer Part number	Gewinde Thread	D _{min}	Z	P	d ₁	d ₂	d ₃	l ₁	l ₃	l ₄	ES15
DCG.3.M1.025.2.1.03	M1	0,75	3	0,25	0,7	3	0,33	34	3	22	▲
DCG.3.M11.025.2.1.03	M1,1	0,8	3	0,25	0,75	3	0,4	34	2,75	22	Δ
DCG.3.M12.025.2.1.03	M1,2	0,9	3	0,25	0,8	3	0,43	34	3	22	▲
DCG.3.M14.030.2.1.03	M1,4	1,1	3	0,3	1	3	0,43	34	4	22	▲
DCG.3.M16.035.2.1.03	M1,6	1,2	3	0,35	1,1	3	0,53	34	4	22	▲
DCG.3.M2.040.2.1.03	M2	1,7	3	0,4	1,5	3	0,93	34	6	22	▲
DCG.3.M22.045.2.1.03	M2,2	1,9	3	0,45	1,7	3	1,13	34	6	22	▲
DCG.3.M25.045.2.1.03	M2,5	2,2	3	0,45	2	3	1,3	34	8	22	▲
											P ●
											M ○
											K ●
											N -
											S -
											H -



z3

60°

z4

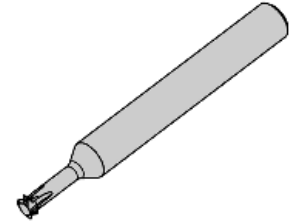
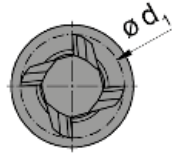
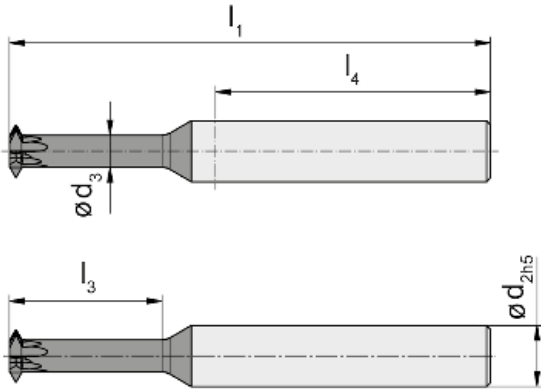

HM-Sorten
Carbide grades

▲ ab Lager
on stock

△ 4 Wochen
4 weeks

Bestellnummer Part number	Gewinde Thread	D _{min}	Z	P	P _{max}	d ₁	d ₂	d ₃	l ₁	l ₃	l ₄	AN25
DCG.3.M3.025.2.1.04	M3	2,4	3	0,25	0,35	2	4	1,45	39	8	22	▲
DCG.3.M3.035.2.1.04	M3	2,4	3	0,25	0,35	2	4	1,35	39	8	22	▲
DCG.3.M3.050.2.1.04	M3	2,4	3	0,5	0,5	2	4	1,2	39	8	22	▲
DCG.3.M35.050.2.1.04	M3,5	2,7	3	0,5	0,6	2,3	4	1,35	39	8	22	▲
DCG.3.M4.070.3.1.06	M4	3,3	3	0,7	0,75	2,8	6	1,7	50	10	36	▲
DCG.3.M5.050.3.1.06	M5	4,2	3	0,5	0,75	3,6	6	2,5	50	10	36	▲
DCG.3.M5.080.3.1.06	M5	4,2	3	0,8	1	3,6	6	2,2	50	10	36	▲
DCG.4.M6.100.3.1.06	M6	5	4	1	1,25	4,3	6	2,4	63	10	40	▲
DCG.4.M6.100.5.1.06	M6	5	4	1	1,25	4,3	6	2,4	63	16	40	▲
DCG.4.M8.075.5.1.08	M8-M10	6,5	4	0,75	1	5,5	8	3,85	63	16	40	▲
DCG.4.M8.075.6.1.08	M8-M10	6,5	4	0,75	1	5,5	8	3,85	63	20	36	▲
DCG.4.M8.075.7.1.08	M8-M10	6,5	4	0,75	1	5,5	8	3,85	77	25	40	▲
DCG.4.M8.125.6.1.08	M8-M10	6,5	4	1,25	1,5	5,5	8	3,4	63	20	36	▲
DCG.4.M8.125.8.1.08	M8-M10	6,5	4	1,25	1,5	5,5	8	3,4	77	30	40	▲
DCG.4.M10.150.6.1.08	M10-M12	8	4	1,5	1,75	6,8	8	4,1	63	20	36	▲
DCG.4.M10.150.8.1.08	M10-M12	8	4	1,5	1,75	6,8	8	4,1	77	30	40	▲

P ●

M ○

K -

N -

S -

H -



z3

z4

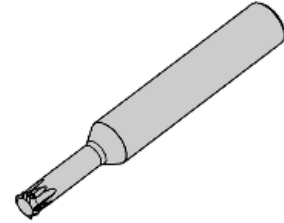
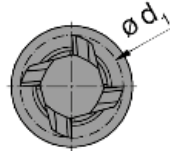
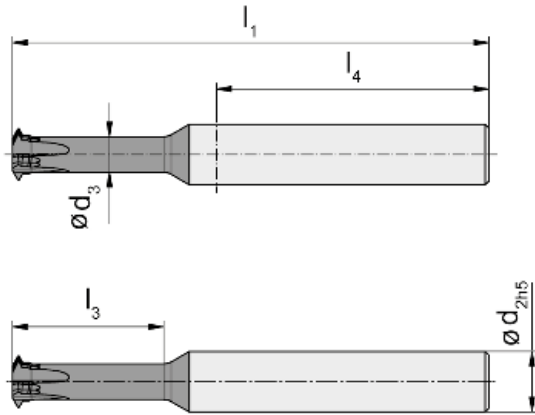

HM-Sorten
Carbide grades

▲ ab Lager
on stock

△ 4 Wochen
4 weeks

Bestellnummer Part number	Gewinde Thread	D _{min}	Z	P	d ₁	d ₂	d ₃	l ₁	l ₃	l ₄	AN25
DCG.3.M3.035.2.2.04	M3	2,4	3	0,35	2	4	1,4	39	8	22	▲
DCG.3.M3.050.2.2.04	M3	2,4	3	0,5	2	4	1,25	39	8	22	▲
DCG.3.M4.070.3.2.06	M4	3,3	3	0,7	2,8	6	1,9	50	10	36	▲
DCG.3.M5.050.3.2.06	M5	4,2	3	0,5	3,6	6	2,85	50	10	36	▲
DCG.4.M6.075.5.2.06	M6	5	4	0,75	4,2	6	3,1	63	16	40	▲
DCG.4.M6.100.5.2.06	M6	5	4	1	4,2	6	2,8	63	16	40	▲
DCG.4.M8.125.5.2.08	M8	6,5	4	1,25	5,5	8	3,7	63	16	40	▲
DCG.4.M10.100.6.2.08	M10	8	4	1	6,8	8	5,4	63	20	36	▲
DCG.4.M10.100.7.2.08	M10	8	4	1	6,8	8	5,4	77	25	40	▲
DCG.4.M10.150.6.2.08	M10	8	4	1,5	6,8	8	4,7	63	20	36	▲
DCG.4.M12.100.6.2.10	M12	10	4	1	8	10	6,3	63	20	36	▲
DCG.4.M12.125.8.2.10	M12	10	4	1,25	8	10	6,1	77	30	40	▲
DCG.4.M12.175.6.2.10	M12	10	4	1,75	8	10	5,5	63	20	36	▲
DCG.4.M12.175.8.2.10	M12	10	4	1,75	8	10	5,5	77	30	40	▲

P	●
M	o
K	-
N	-
S	-
H	-

UN z3 z4

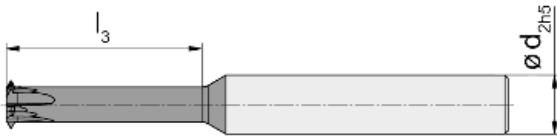
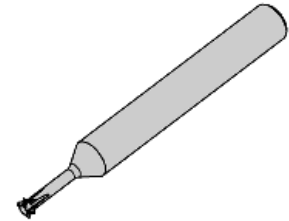
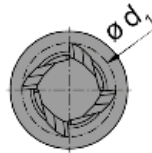
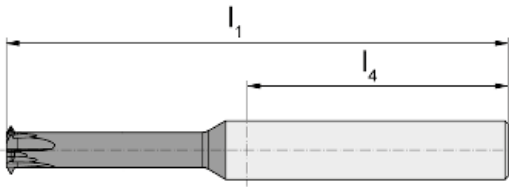

HM-Sorten
Carbide grades

▲ ab Lager
on stock

△ 4 Wochen
4 weeks

Bestellnummer Part number	Gewinde Thread	D _{min}	Z	P	d ₁	d ₂	d ₃	l ₁	l ₃	l ₄	AN25
DCG.3.60.540.2.04	#5 - 40 UNC	2,4	3	0,635	2	4	1,1	39	8	22	▲
DCG.3.60.632.2.04	#6 - 32UNC #8 - 32UNC	2,6	3	0,794	2,2	4	-	39	8	22	▲
DCG.4.60.1420.3.06	1/4" - 20 UNC	4,9	4	1,27	3,5	6	-	63	10	40	▲
DCG.4.60.1428.3.06	1/4" - 28 UNF	5,3	4	0,907	3,5	6	-	63	10	40	▲
DCG.4.60.51618.3.06	5/16" - 18 UNC	6,4	4	1,411	4,2	6	-	63	10	40	▲
DCG.4.60.3816.7.08	3/8" - 16 UNC	7,8	4	1,588	5,5	8	-	77	25	40	▲
DCG.4.60.71620.7.08	7/16" - 20 UNF	9,1	4	1,27	7,2	8	-	77	30	40	▲
DCG.4.60.1213.7.08	1/2" - 13 UNC	10,5	4	1,953	7,9	8	-	77	30	40	▲
											P ●
											M o
											K -
											N -
											S -
											H -

Gewindefräser Thread Milling Cutter

DCG



A

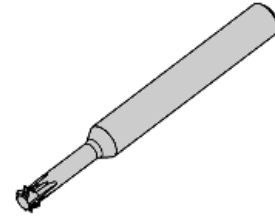
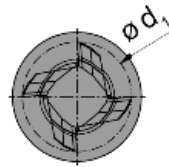
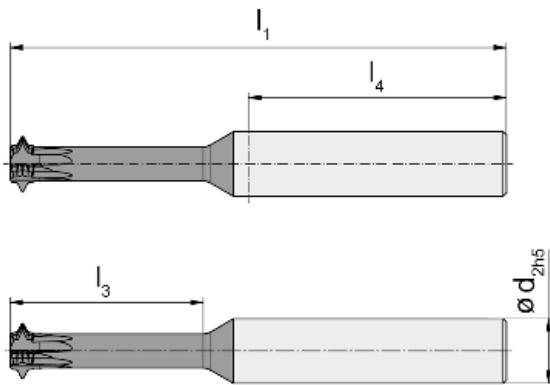
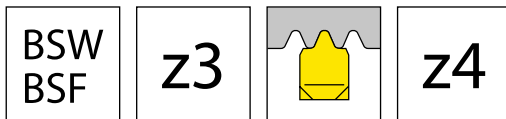

HM-Sorten
Carbide grades

▲ ab Lager
on stock

△ 4 Wochen
4 weeks

Bestellnummer Part number	Gewinde Thread	D _{min}	Z	P	d ₁	d ₂	d ₃	l ₁	l ₃	l ₄	AN25
DCG.3.55.1840.2.04	1/8" - 40 BSW	2,3	3	0,635	2	4	1	39	8	22	▲
DCG.3.55.53232.2.04	5/32" - 32 BSW	2,9	3	0,794	2,3	4	-	39	8	22	▲
DCG.3.55.31632.3.06	3/16" - 32 BSF	3,7	3	0,794	2,8	6	-	50	10	36	▲
DCG.3.55.73224.3.06	7/32" - 24 BSW	4,2	3	1,058	3,6	6	-	50	10	36	△
DCG.3.55.73228.3.06	7/32" - 28 BSF	4,3	3	0,907	3,6	6	-	50	10	36	▲
DCG.3.55.1420.5.06	1/4" - 20 BSW	4,7	3	1,27	4	6	-	63	16	40	▲
DCG.3.55.1426.5.06	1/4" - 26 BSF	5	3	0,977	4,2	6	-	63	16	40	▲
DCG.4.55.51618.5.06	5/16" - 18 BSW	6,1	4	1,411	5,2	6	-	63	16	40	▲
DCG.4.55.93226.5.06	9/32" - 26 BSF	5,8	4	0,977	5	6	-	63	16	40	△
DCG.4.55.3816.5.08	3/8" - 16 BSW	7,4	4	1,588	6,3	8	-	63	16	40	▲
DCG.4.55.3820.5.08	3/8" - 20 BSF	7,8	4	1,27	6,5	8	-	63	16	40	▲
DCG.4.55.71614.5.08	7/16" - 14 BSW	8,7	4	1,814	7,2	8	-	63	16	40	▲
DCG.4.55.71614.7.08	7/16" - 14 BSW	8,7	4	1,814	7,2	8	-	77	25	40	▲
DCG.4.55.71618.5.08	7/16" - 18 BSF	9,3	4	1,411	7,5	8	-	63	16	40	△
DCG.4.55.71618.7.08	7/16" - 18 BSF	9,3	4	1,411	7,5	8	-	77	25	40	△
DCG.4.55.1212.6.10	1/2" - 12 BSW	9,9	4	2,117	8,5	10	-	63	20	40	▲
DCG.4.55.1212.8.10	1/2" - 12 BSW	9,9	4	2,117	8,5	10	5,25	77	30	40	▲
DCG.4.55.1216.6.10	1/2" - 16 BSF	10,6	4	1,588	9,5	10	-	63	20	40	△

P	●
M	○
K	-
N	-
S	-
H	-

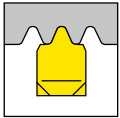

z4

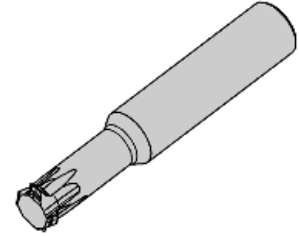
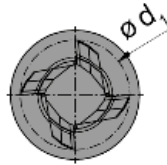
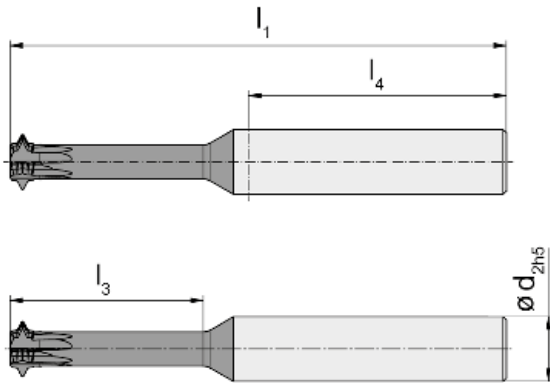

HM-Sorten
Carbide grades

▲ ab Lager
on stock

△ 4 Wochen
4 weeks

Bestellnummer Part number	Gewinde Thread	D _{min}	Z	P	d ₁	d ₂	d ₃	l ₁	l ₃	l ₄	AN25
DCG.4.55.G18.5.08	G 1/8"	8,5	4	0,91	6,6	8	3,9	63	16	40	▲
DCG.4.55.G14.6.10	G 1/4"	11,4	4	1,34	9,5	10	7,1	63	20	40	▲
DCG.4.55.G38.8.10	G 3/8"	14,9	4	1,34	9,8	10	9,4	77	30	40	▲
											P ●
											M ○
											K -
											N -
											S -
											H -

Nutfräser

Groove milling cutter

DCR



A

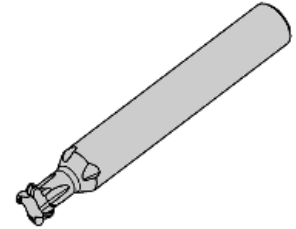
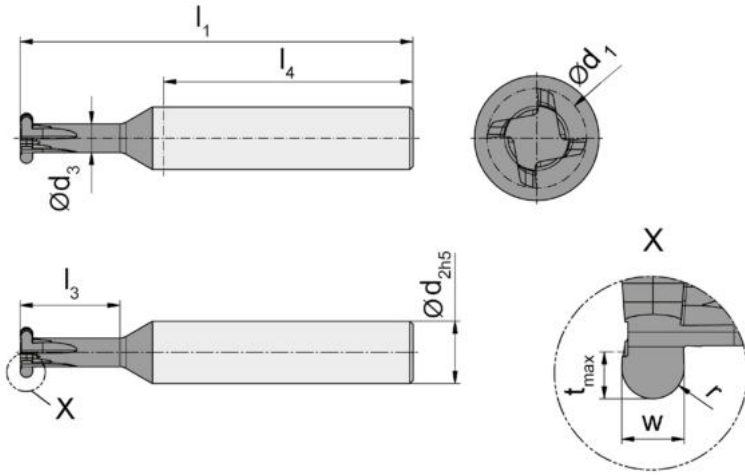
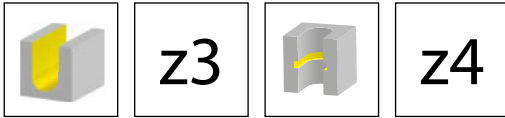

HM-Sorten
Carbide grades

▲ ab Lager
on stock

Δ 4 Wochen
4 weeks

Bestellnummer Part number	Z	w	t _{max}	r	d ₁	d ₂	d ₃	l ₁	l ₃	l ₄	AN25
DCR.3.40.10.05.1.06	3	1	0,5	0,5	4	6	2,75	50	4	36	▲
DCR.3.60.10.05.1.06	3	1	1	0,5	6	6	3,7	50	4	36	▲
DCR.3.60.10.05.2.06	3	1	1	0,5	6	6	3,7	63	6	40	▲
DCR.3.60.15.75.2.06	3	1,5	1	0,75	6	6	3,7	63	6	40	▲
DCR.4.80.15.75.3.08	4	1,5	1,5	0,75	8	8	4,6	63	8	40	▲
DCR.4.80.15.75.5.08	4	1,5	1,5	0,75	8	8	4,6	63	16	40	▲
DCR.4.80.20.10.3.08	4	2	1,5	1	8	8	4,6	63	8	40	▲
DCR.4.80.20.10.5.08	4	2	1,5	1	8	8	4,6	63	16	40	▲
DCR.4.100.10.05.6.10	4	1	2	0,5	10	10	5,5	77	20	55	▲
DCR.4.100.15.75.6.10	4	1,5	2	0,75	10	10	5,5	77	20	55	▲
DCR.4.100.20.10.6.10	4	2	2	1	10	10	5,5	77	20	55	▲
DCR.4.100.25.12.6.10	4	2,5	2	1,25	10	10	5,5	77	20	55	▲
DCR.4.100.30.15.6.10	4	3	2	1,5	10	10	5,5	77	20	55	▲
P	●										
M	o										
K	-										
N	-										
S	-										
H	-										

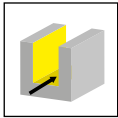

z3

z4

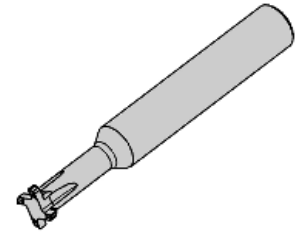
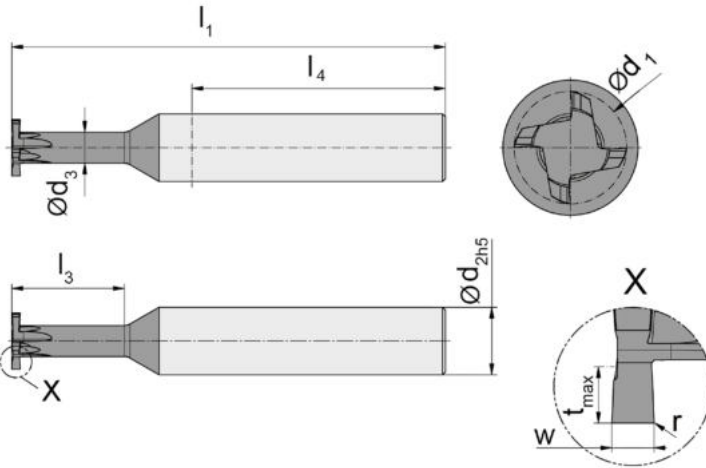

HM-Sorten
Carbide grades

▲ ab Lager
on stock

△ 4 Wochen
4 weeks

Bestellnummer Part number	Z	w	t _{max}	r	d ₁	d ₂	d ₃	l ₁	l ₃	l ₄	AN25
DCN.3.30.05.00.1.06	3	0,5	0,4	-	3	6	2	50	3	36	▲
DCN.3.30.05.00.2.06	3	0,5	0,4	-	3	6	2	50	5	36	▲
DCN.3.30.10.00.1.06	3	1	0,4	-	3	6	2	50	3	36	▲
DCN.3.30.10.00.2.06	3	1	0,4	-	3	6	2	50	5	36	▲
DCN.3.40.05.00.1.06	3	0,5	0,5	-	4	6	2,8	50	4	36	▲
DCN.3.40.10.00.1.06	3	1	0,5	-	4	6	2,8	50	4	36	▲
DCN.3.60.10.00.1.06	3	1	1	-	6	6	3,7	50	4	36	▲
DCN.3.60.10.00.2.06	3	1	1	-	6	6	3,7	63	6	40	▲
DCN.3.60.15.15.2.06	3	1,5	1	0,15	6	6	3,7	63	6	40	▲
DCN.4.80.15.15.3.08	4	1,5	1,5	0,15	8	8	4,6	63	8	40	▲
DCN.4.80.15.15.5.08	4	1,5	1,5	0,15	8	8	4,6	63	16	40	▲
DCN.4.80.20.15.3.08	4	2	1,5	0,15	8	8	4,6	63	8	40	▲
DCN.4.80.20.15.5.08	4	2	1,5	0,15	8	8	4,6	63	16	40	▲
DCN.4.100.10.00.6.10	4	1	2	-	10	10	5,5	77	20	50	▲
DCN.4.100.15.00.6.10	4	1,5	2	-	10	10	5,5	77	20	50	▲
DCN.4.100.20.15.6.10	4	2	2	0,15	10	10	5,5	77	20	50	▲
DCN.4.100.25.15.6.10	4	2,5	2	0,15	10	10	5,5	77	20	50	▲
DCN.4.100.30.15.6.10	4	3	2	0,15	10	10	5,5	77	20	50	▲

P	●
M	o
K	-
N	-
S	-
H	-

Nutfräser

Groove milling cutter

DCX



A

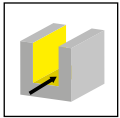

z6

z8

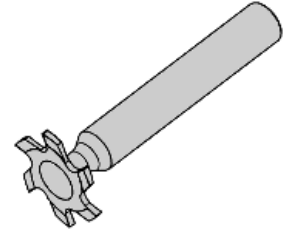
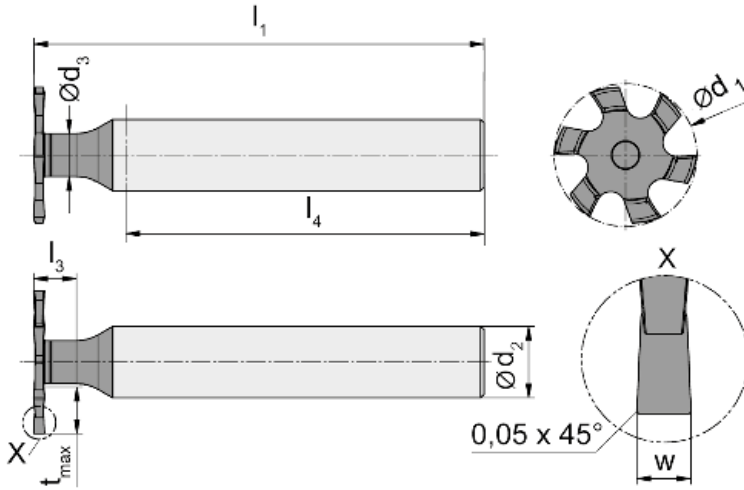

HM-Sorten
Carbide grades

▲ ab Lager
on stock

△ 4 Wochen
4 weeks

Bestellnummer Part number	Z	w	t _{max}	d ₁	d ₂	d ₃	l ₁	l ₃	l ₄	AS/45
DCX.6.20.150.2.05.10	6	1,5	7	20	10	5	63	6	50	▲
DCX.6.20.200.2.05.10	6	2	7	20	10	5	63	6	50	▲
DCX.6.20.250.2.05.10	6	2,5	7	20	10	5	63	6	50	▲
DCX.6.25.150.2.06.10	6	1,5	9	25	10	6	63	6	51	▲
DCX.6.25.200.2.06.10	6	2	9	25	10	6	63	6	51	▲
DCX.6.25.250.2.06.10	6	2,5	9	25	10	6	63	6	51	▲
DCX.6.30.150.4.07.12	6	1,5	11	30	12	7	80	9	65	▲
DCX.6.30.200.4.07.12	6	2	11	30	12	7	80	9	65	▲
DCX.6.30.250.4.07.12	6	2,5	11	30	12	7	80	9	65	▲
DCX.6.30.300.4.07.12	6	3	11	30	12	7	80	9	65	▲
DCX.6.35.150.4.08.12	6	1,5	13	35	12	8	80	11	64	▲
DCX.6.35.200.4.08.12	6	2	13	35	12	8	80	11	64	▲
DCX.6.35.250.4.08.12	6	2,5	13	35	12	8	80	11	64	▲
DCX.6.35.300.4.08.12	6	3	13	35	12	8	80	11	64	▲
DCX.8.40.150.4.09.12	8	1,5	15	40	12	9	80	11	65	▲
DCX.8.40.200.4.09.12	8	2	15	40	12	9	80	11	65	▲
DCX.8.40.250.4.09.12	8	2,5	15	40	12	9	80	11	65	▲
DCX.8.40.300.4.09.12	8	3	15	40	12	9	80	11	65	▲

P	●
M	●
K	●
N	○
S	●
H	-

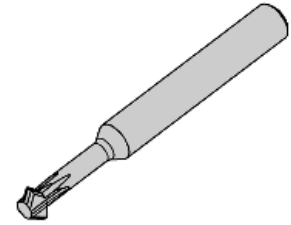
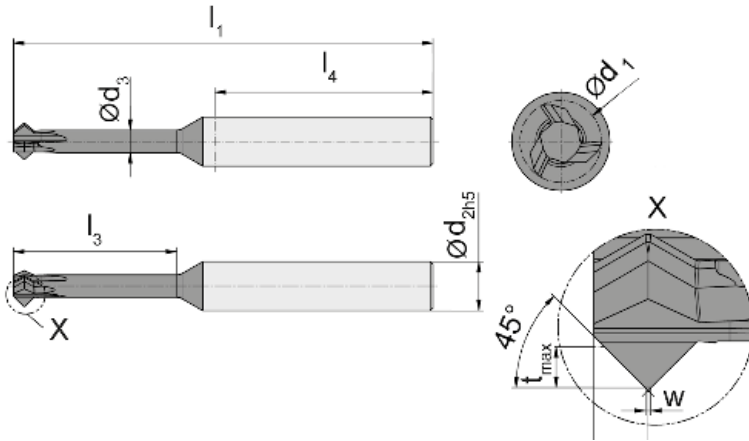
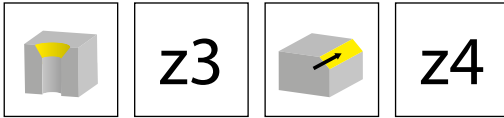

HM-Sorten
Carbide grades

▲ ab Lager
on stock

△ 4 Wochen
4 weeks

Bestellnummer Part number	Z	w	Fase Chamfer	t_{max}	d_1	d_2	d_3	l_1	l_3	l_4	AN25
DCF.3.20.4545.1.04	3	0,2	45°	0,3	2	4	1,25	39	4	22	▲
DCF.3.30.4545.2.04	3	0,2	45°	0,3	3	4	2,1	39	6	22	▲
DCF.3.40.4545.3.06	3	0,2	45°	0,75	4	6	2,2	50	8	36	▲
DCF.3.50.4545.3.06	3	0,2	45°	1	5	6	2,7	50	10	36	▲
DCF.3.60.4545.5.06	3	0,2	45°	1,25	6	6	3,15	63	16	40	▲
DCF.3.60.4545.6.06	3	0,2	45°	1,25	6	6	3,15	63	20	40	▲
DCF.3.75.4545.6.08	3	0,2	45°	1,5	7,5	8	4,1	63	20	40	▲
DCF.3.75.4545.8.08	3	0,2	45°	1,5	7,5	8	4,1	77	30	40	▲
DCF.4.75.4545.8.08	4	0,2	45°	1,5	7,5	8	4,1	77	30	40	▲
											P ●
											M o
											K -
											N -
											S -
											H -

Werkstoff Material		Materialgruppe Material group	Härte (HB) Hardness Brinell	Zug- festigkeit R_m [N/mm ²] Tensile Strength	Beispiel Werkstoff Example Material	Schnittgeschwindigkeit v_c (m/min) / Startwerte Cutting speed v_c (m/min) / Start values		
						ES1_ AN2_ AS4_	fz	
P	unlegierter Stahl Carbon steel	~ 0,2 % C	P1.1	125	430	CK15	250-180	0,01 -0,03
		~ 0,4% C geglüht annealed	P1.2	190	610	19Mn6	220-160	0,01 -0,03
		~ 0,4% C vergütet quenched	P1.3	210	640	36Mn5	200-140	0,01 -0,03
		~ 0,6% C geglüht annealed	P1.4	190	610	C55	180-120	0,01 -0,03
		~ 0,6% C vergütet quenched	P1.5	300	1000	CK60	150-90	0,01 -0,03
		Automatenstahl Free cutting steel	P1.6	220	750	9SMn28	250-180	0,01 -0,03
	niedrig legierter Stahl (<5%) Alloyed steel	gegüht annealed	P2.1	180	590	100Cr6	200-140	0,01 -0,03
		vergütet quenched	P2.2	280	960	14NiCr10	150-90	0,01 -0,03
		vergütet quenched	P2.3	350	1250	34CrMo4	140-80	0,01 -0,03
		vergütet quenched	P2.4	430	1450	55Cr3	140-80	0,01 -0,03
	hochlegierter Stahl (>5%) high alloyed steel	gegüht annealed	P3.1	200	680	X10CrAl18	180-120	0,01 -0,03
		gehärtet hardened	P3.2	350	1200	X210Cr2	140-80	0,01 -0,03
	Stahlguss Cast steel	unlegiert unalloyed	P4.1	180	590	GE200	250-180	0,01 -0,03
		legiert alloyed	P4.2	220	750	GX40CrSi28	220-160	0,01 -0,03
	Sinterstahl Sintered steel	weich soft	P5.1	220	570	Sint-D39		0,01 -0,03
M	Rostfreier Stahl Stainless steel	martensitisch ferritisch martensitic ferritic	M1.1	200	680	X16Cr13	150-90	0,01 -0,03
		austenitisch austenitic ferritic	M1.2	300	1000	X6CrNiMo- Ti17-12-2	140-80	0,01 -0,03
		austenitisch ferritisch austenitic	M1.3	230	780	X2CrNi- MoN17-13-3	120-60	0,01 -0,03
H	Gehärtete Stähle Hardened steels	50-55 HRC	H1.1	-	-			
		55-60 HRC	H1.2	-	-			
		60-63 HRC	H1.3	-	-			
		> 63HRC	H1.4	-	-			

Werkstoff Material		Materialgruppe Material group	Härte (HB) Hardness Brinell	Zug- festigkeit R_m [N/mm ²] Tensile Strength	Beispiel Werkstoff Example Material	Schnittgeschwindigkeit vc (m/min) / Startwerte Cutting speed vc (m/min) / Start values		
						ES1_ AN2_ AS4_	fz	
K	Grauguss Grey cast iron	niedrige Festigkeit low tensile strength	K1.1	180	250	GG-25	230-190	0,01 -0,03
		hohe Festigkeit high tensile strength	K1.2	250	350	GG-40	230-190	0,01 -0,03
	Kugelgraphit- guss Spheroidal graphite cast iron	ferritisch ferritic	K2.1	160	400	GGG-40	220-160	0,01 -0,03
		perlitisches perlitic	K2.1	260	700	GGG-60	220-160	0,01 -0,03
	Temperguss Malleable cast iron	ferritisch ferritic	K3.1	200	400	GTW-45	220-160	0,01 -0,03
		perlitisches perlitic	K3.2	260	700	GTS-55-04	220-160	0,01 -0,03
	Ausferritisches Gusseisen / ADI Ausferritic spheroidal cast iron / ADI	vergütet quenched	K4.1	260	800			
		vergütet quenched	K4.2	350	1050			
		vergütet quenched	K4.3	450	1400			
N	Al-Legierungen Al-alloys	nicht vergütbar not heat treatable	N1.1	30		AlMg1	bis 1000	0,02 - 0,04
		vergütbar heat treatable	N1.2	100	340	AlMgSi1	600-200	0,02 - 0,04
	Al-Guss- Legierung Al-cast-alloy	< 6% Si	N2.1	80	300	AlMgSi6	400-200	0,02 - 0,04
		6-10% Si	N2.2	100	320	AlSi7Mg		
		10-15 % Si	N2.3	130	450	AlSi12		
	Kupfer- Legierungen Copper-alloys	Reinkupfer Pure copper	N3.1	100	340	Cu	400-200	0,02 - 0,04
		Messing, Bronze Brass	N3.2	90	310	CuZn40Pb	400-200	0,02 - 0,04
		Messing bleifrei Lead-free brass	N3.3	110	430	CuZn40	400-200	0,02 - 0,04
		hochfest high strength	N3.4	300	1000	CuZn25Al- 5Mn4Fe3	160-100	0,02 - 0,04
	Graphit Graphite		N4.1					
S	Warmfeste Legierung (Fe) Heat resistant alloy	geglüht annealed	S1.1	200	670		120-60	0,02 - 0,04
		gehärtet hardened	S1.2	275	930		120-60	0,02 - 0,04
	Warmfeste Legierung (Ni, Co) Heat resistant alloy	geglüht annealed	S2.1	250	840	Inconel 600	90-30	0,02 - 0,04
		gehärtet hardened	S2.2	350	1200	Inconel 713	90-30	0,02 - 0,04

Werkstoff Material	Materialgruppe Material group	Härte (HB) Hardness Brinell	Zug- festigkeit R _m [N/mm ²] Tensile Strength	Beispiel Werkstoff Example Material	Schnittgeschwindigkeit vc (m/min) / Startwerte Cutting speed vc (m/min) / Start values		
					ES1_ AN2_ AS4_	fz	
S Titan	Titanlegierung α Titanium alloy α	S3.1	120	240		120-80	0,02 - 0,04
	Titanlegierung α-β Titanium alloy α-β	S3.2	360	1200		120-80	0,02 - 0,04
	Titanlegierung β Titanium alloy β	S3.3	410	1400		120-80	0,02 - 0,04
O	Thermoplaste Thermoplastics	01.1					
	Duroplaste Duroplaste	01.2					
	Kunststoffe glasfaser- verstärkt Plastics glass fibre reinforced	GFK	01.3				
	Kunststoffe kohlefaser- verstärkt Plastics carbon fibre reinforced	CKF	01.4				

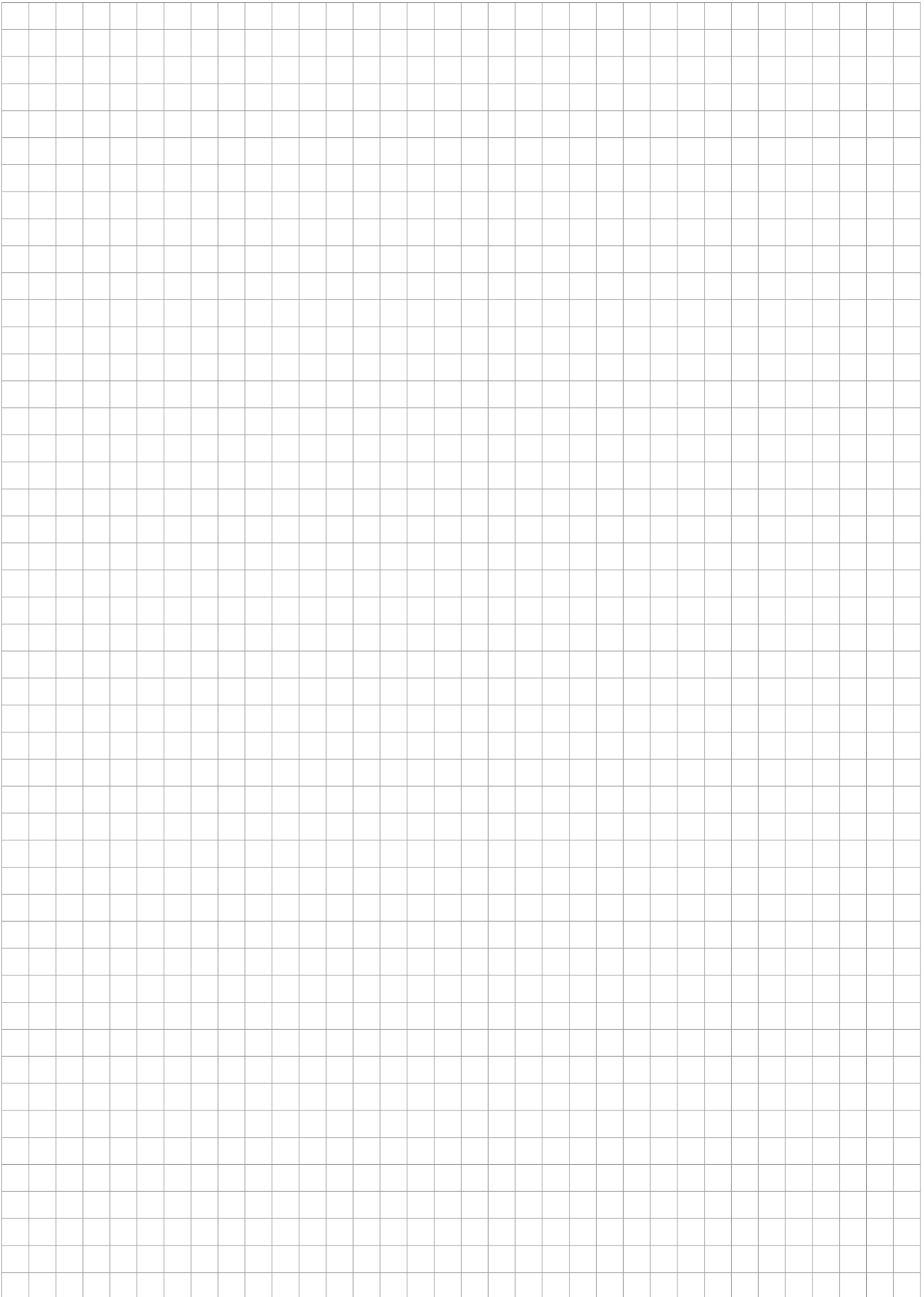



System/System	Seite/Page
M304	28
M306	36
M308	66
M311	88
M116	110
M313	116
M328	150
M332	176
M335	200
M620	204

Nutfräsen (zirkular)

Groove Milling by circular interpolation



B

Frälerschaft
Milling shank
M304/M304.ST

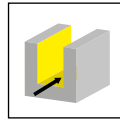

Seite/Page
30-31

Schneidplatte
Insert
304

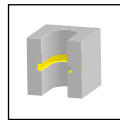

Seite/Page
32

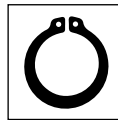

Seite/Page
33

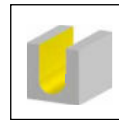

Seite/Page
34

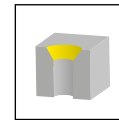

Seite/Page
35

M304



**Fräser mit wechselbarer
Schneidplatte**

ab Bohrung \varnothing 7,7 mm

**Milling shank with
exchangeable insert**

from bore \varnothing 7,7 mm

Frärschaft

Milling shank

M304



B

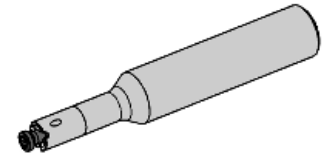
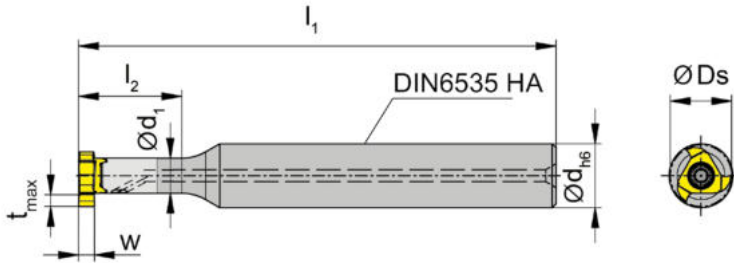
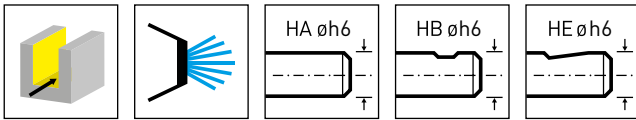

Bestellnummer Part number	d	l ₁	l ₂	d ₁	Form	HWS
M304.0008.01A	8	60	13	4,4	A	304044R
M304.0008.02A	8	64	17	4,4	A	304044R
M304.0008.03A	8	68	21	4,4	A	304044R
M304.0008.01B	8	60	13	4,4	B	304044R
M304.0008.02B	8	64	17	4,4	B	304044R
M304.0008.03B	8	68	21	4,4	B	304044R
M304.0008.01E	8	60	13	4,4	E	304044R
M304.0008.02E	8	64	17	4,4	E	304044R
M304.0008.03E	8	68	21	4,4	E	304044R

w, Ds, tmax siehe Schneidplatte
w, Ds, tmax see inserts

Ersatzteile

Spare Parts

Frärschaft Milling shank	Spannschraube Clamping Screw	TORX PLUS®-Schlüssel TORX PLUS® Wrench
M304...	1.8.4T6EP	T6PL

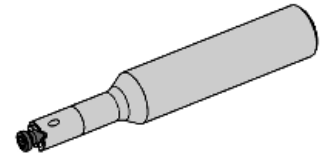
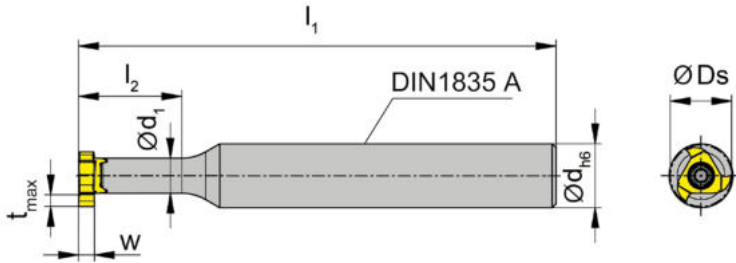
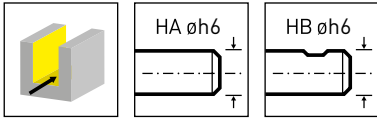

Bestellnummer Part number	d	l ₁	l ₂	d ₁	Form	HWS
M304.ST08.01A	8	60	13	4,4	A	304044R
M304.ST08.01B	8	60	13	4,4	B	304044R

w, Ds, tmax siehe Schneidplatte
w, Ds, tmax see inserts

Ersatzteile
Spare Parts

Fräserschaft Milling shank	Spannschraube Clamping Screw	TORX PLUS®-Schlüssel TORX PLUS® Wrench
M304...	1.8.4T6EP	T6PL

B

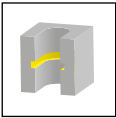

z3



Abbildung = rechtsschneidend
Picture = right hand cutting version

▲ ab Lager
on stock

HM-Sorten
Carbide grades

△ 4 Wochen
4 weeks

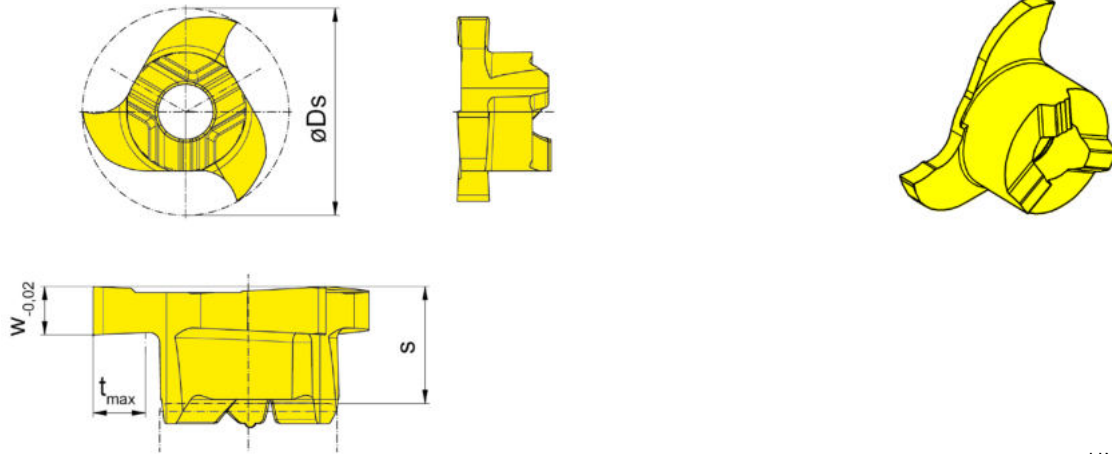
Bestellnummer Part number	Ds	w	s	r	t _{max}	Z	HIS	EG35	EG55	IG35
304.0025.20	7,7	0,25	2,6	-	1,3	3	304044R	▲		△
304.0030.20	7,7	0,3	2,6	-	1,3	3	304044R	▲		△
304.0040.20	7,7	0,4	2,6	-	1,3	3	304044R	▲		△
304.0050.20	7,7	0,5	2,6	-	1,3	3	304044R		▲	▲
304.0060.20	7,7	0,6	2,6	-	1,3	3	304044R	▲		△
304.0070.20	7,7	0,7	2,6	-	1,3	3	304044R	▲		△
304.0100.20	7,7	1	2,6	-	1,3	3	304044R		▲	▲
304.0150.20	7,7	1,5	2,9	0,1	1,3	3	304044R		▲	▲
304.0200.20	7,7	2	2,9	0,2	1,3	3	304044R		▲	▲
P	●	●	-							
M	●	○	●							
K	○	○	-							
N	-	-	-							
S	-	-	●							
H	-	-	-							



Abbildung = rechtsschneidend
Picture = right hand cutting version

HM-Sorten
Carbide grades
▲ ab Lager
on stock
Δ 4 Wochen
4 weeks

Bestellnummer Part number	Ds	Nw	w	s	t _{max}	Z	HIS	EG55	IG35
304.0080.20	7,7	0,8	0,87	2,6	1,3	3	304044R	▲	▲
304.0090.20	7,7	0,9	0,97	2,6	1,3	3	304044R	▲	▲
304.0110.20	7,7	1,1	1,21	2,9	1,3	3	304044R	▲	▲
304.0130.20	7,7	1,3	1,41	2,9	1,3	3	304044R	▲	▲
								P	● -
								M	○ ●
								K	○ -
								N	- -
								S	- ●
								H	- -

B

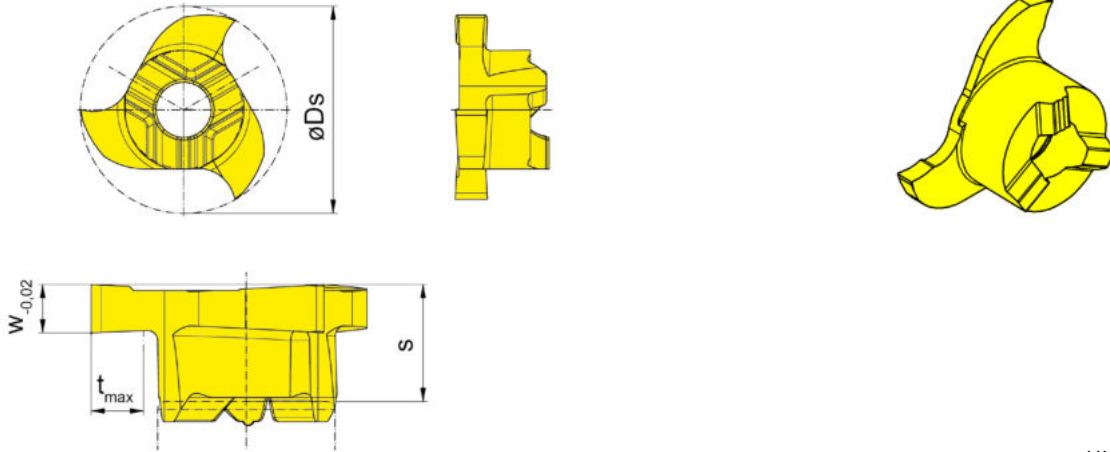

z3



Abbildung = rechtsschneidend
Picture = right hand cutting version

▲ ab Lager
on stock

HM-Sorten
Carbide grades
Δ 4 Wochen
4 weeks

Bestellnummer Part number	Ds	w	s	r	t _{max}	Z	HIS	EG55	IG35
304.0004.08	7,7	0,8	2,6	0,4	1,3	3	304044R	▲	▲
304.0006.12	7,7	1,2	2,9	0,6	1,3	3	304044R	▲	▲
304.0008.16	7,7	1,6	2,9	0,8	1,3	3	304044R	Δ	Δ
								P ● -	
								M ○ ●	
								K ○ -	
								N - -	
								S - ●	
								H - -	

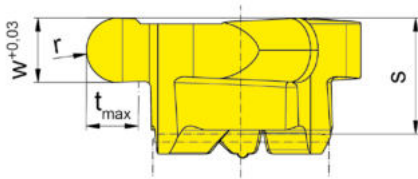
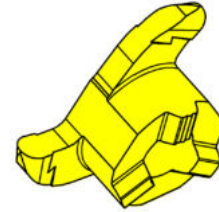
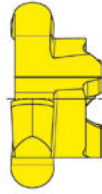
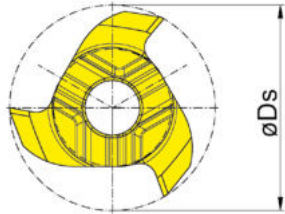
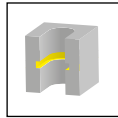

Abbildung = rechtsschneidend
Picture = right hand cutting version

▲ ab Lager
on stock

HM-Sorten
Carbide grades
Δ 4 Wochen
4 weeks

Bestellnummer Part number	D_s	E	s	w	α	b	t_{max}	Z	HIS	EG55	IG35
304.1515.20	7,7	1,4	2,75	0,2	15°	1	0,3	3	304044R	Δ	Δ
304.3030.20	7,7	1,4	2,75	0,2	30°	1	0,6	3	304044R	▲	▲
304.4545.20	7,7	1,4	2,75	0,2	45°	1	1	3	304044R	▲	▲
										P	•
										M	○
										K	○
										N	-
										S	-
										H	-

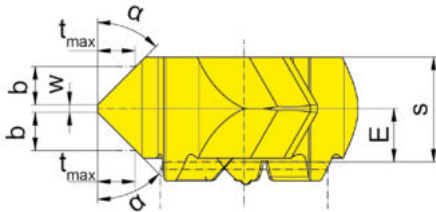
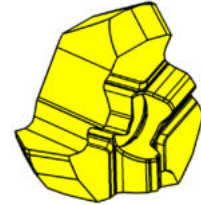
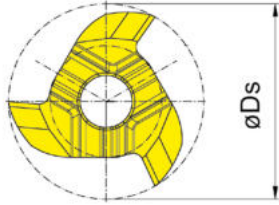
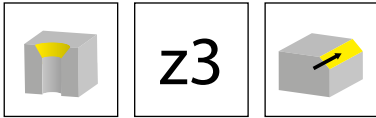
Nutfräsen (zirkular)

Groove Milling by circular interpolation



B

Frälerschaft
Milling shank
M306/M306.ER/M306.ST

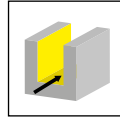

Seite/Page
38-42

Grundaufnahme
Basic Holder
WFB

Seite/Page
43

Einschraubfräser
Screw-in cutter
M306.M

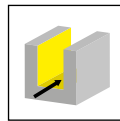

Seite/Page
44

Schneidplatte
Insert
108/306/606

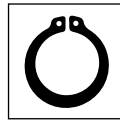

Seite/Page
45-46, 50-54, 60

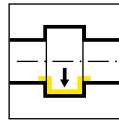

Seite/Page
47

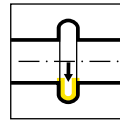

Seite/Page
48

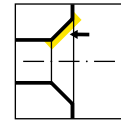

Seite/Page
49



Seite/Page
54, 57

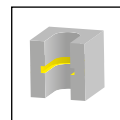

Seite/Page
55-56

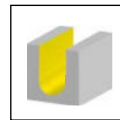

Seite/Page
58

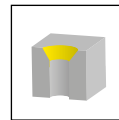

Seite/Page
59, 62-63

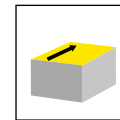

Seite/Page
64-65

M306



**Fräser mit wechselbarer
Schneidplatte**

ab Bohrung \varnothing 10 mm

**Milling shank with
exchangeable insert**

from bore \varnothing 10 mm

Fräserschaft

Milling shank

M306



B

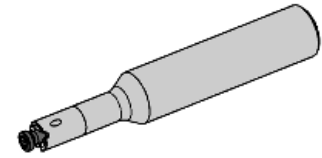
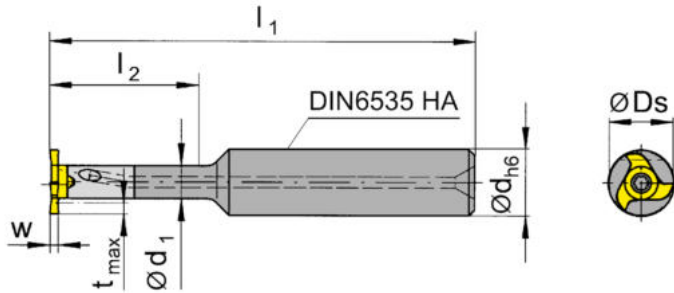
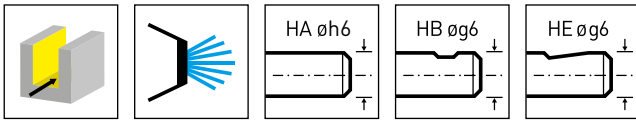

Bestellnummer Part number	d	l ₁	l ₂	d ₁	Form	HWS
M306.0012.01A	12	80	21	6	A	306060R • 306060L
M306.0012.02A	12	90	30	6	A	306060R • 306060L
M306.0012.03A	12	100	42	6	A	306060R • 306060L
M306.0012.01B	12	80	21	6	B	306060R • 306060L
M306.0012.02B	12	90	30	6	B	306060R • 306060L
M306.0012.03B	12	100	42	6	B	306060R • 306060L
M306.0012.01E	12	80	21	6	E	306060R • 306060L
M306.0012.02E	12	90	30	6	E	306060R • 306060L
M306.0012.03E	12	100	42	6	E	306060R • 306060L

w, Ds, tmax siehe Schneidplatte
w, Ds, tmax see inserts

Ersatzteile

Spare Parts

Fräserschaft Milling shank	Spannschraube Clamping Screw	TORX PLUS®-Schlüssel TORX PLUS® Wrench
M306...	2.6.5T8EP	T8PL

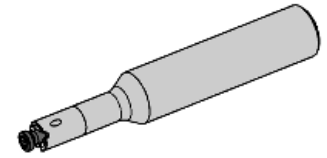
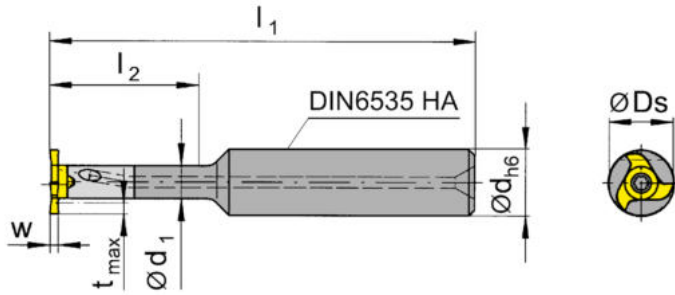
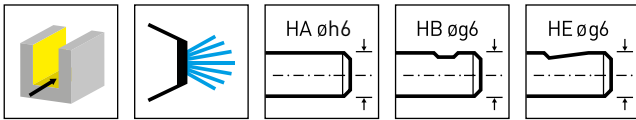

Bestellnummer Part number	d	l ₁	l ₂	d ₁	Form	HWS
M306.0712.02A	12	90	30	7,3	A	306060R • 306060L
M306.0716.01A	16	100	25	7,3	A	306060R • 306060L
M306.0716.02A	16	110	35	7,3	A	306060R • 306060L
M306.0712.02B	12	90	30	7,3	B	306060R • 306060L
M306.0716.01B	16	100	25	7,3	B	306060R • 306060L
M306.0712.02E	12	90	30	7,3	E	306060R • 306060L
M306.0716.01E	16	100	25	7,3	E	306060R • 306060L

w, Ds, tmax siehe Schneidplatte
w, Ds, tmax see inserts

Ersatzteile
Spare Parts

Fräuserschaft Milling shank	Spannschraube Clamping Screw	TORX PLUS®-Schlüssel TORX PLUS® Wrench
M306...	2.6.5T8EP	T8PL

B

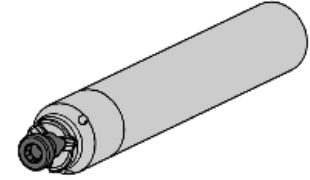
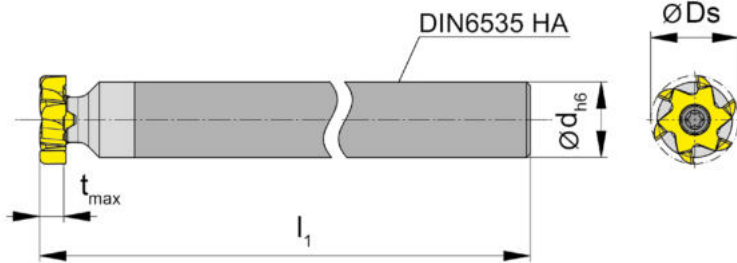
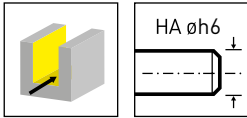

Bestellnummer Part number	d	l ₁	Form	HWS
M306.0707.03A	7,5	100	A	306060R • 306060L
M306.1010.03A	10	120	A	306060R • 306060L

tmax und Ds siehe SP
tmax and Ds see inserts

Ersatzteile

Spare Parts

Fräserschaft Milling shank	Spannschraube Clamping Screw	TORX PLUS®-Schlüssel TORX PLUS® Wrench
M306...	2.6.5T8EP	T8PL

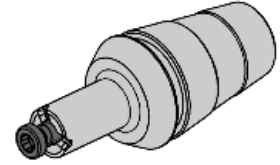
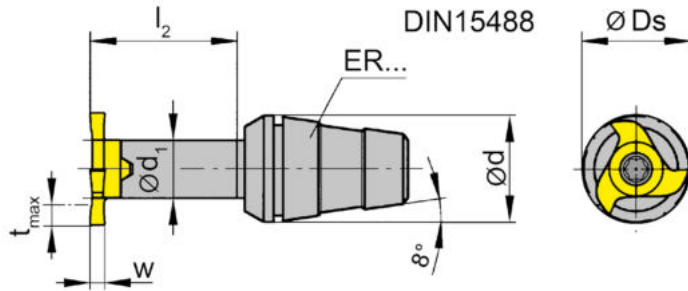

Bestellnummer Part number	d	l ₂	d ₁	Spannmutter Clamping nut	HWS
M306.ER11.02	11	16	6	ER11.6499	306060R • 306060L

w, Ds, tmax siehe Schneidplatte
w, Ds, tmax see inserts

Spannmutter ist nicht im Lieferumfang enthalten - bitte separat bestellen!
Clamping nut is not combined with milling shank - separate order required!

Ersatzteile
Spare Parts

Fräserschaft Milling shank	Spannschraube Clamping Screw	TORX PLUS®-Schlüssel TORX PLUS® Wrench
M306.ER11.02	2.6.5T8EP	T8PL

B

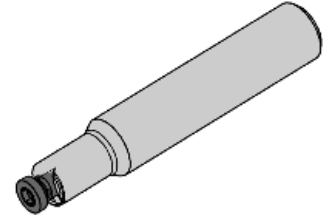
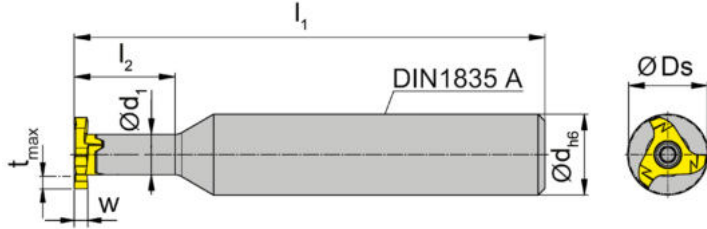
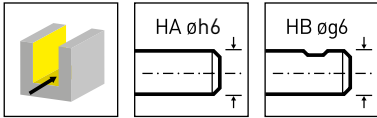

Bestellnummer Part number	d	l ₁	l ₂	d ₁	Form	HWS
M306.ST10.01A	10	60	15	6	A	306060R • 306060L
M306.ST12.01A	12	70	15	6	A	306060R • 306060L
M306.ST10.01B	10	60	15	6	B	306060R • 306060L
M306.ST12.01B	12	70	15	6	B	306060R • 306060L

w, D_s, t_{max} siehe Schneidplatte
w, D_s, t_{max} see inserts

Ersatzteile

Spare Parts

Frälerschaft Milling shank	Spannschraube Clamping Screw	TORX PLUS®-Schlüssel TORX PLUS® Wrench
M306...	2.6.5T8EP	T8PL

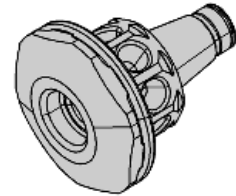
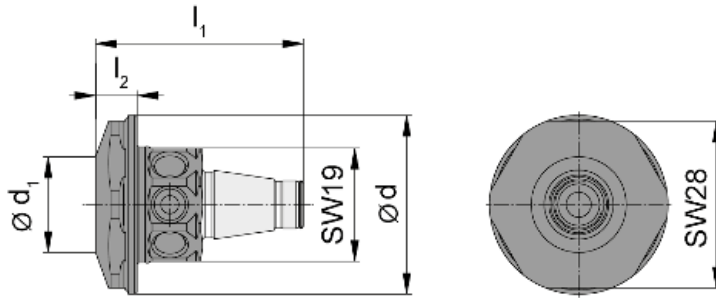

Bestellnummer Part number	l_1	l_2	d_1	d
WFB.2012.M081.01	35	7	16	30

für Einschraubfräser
for Screw-in cutter

B

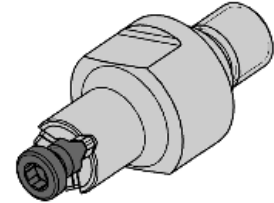
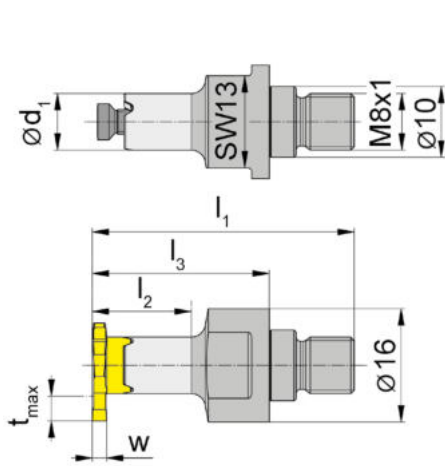
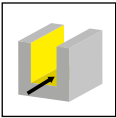

Bestellnummer Part number	l_1	l_2	l_3	d_1	SW
M306.M081.01	37	11	25	6	13

w, D_s , t_{max} siehe Schneidplatte
w, D_s , t_{max} see inserts

Ersatzteile

Spare Parts

Einschraubfräser Screw-in cutter	Spannschraube Clamping Screw	TORX PLUS®-Schlüssel TORX PLUS® Wrench
M306.M081.01	2.6.5T8EP	T8PL

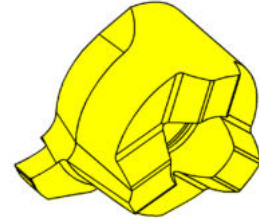
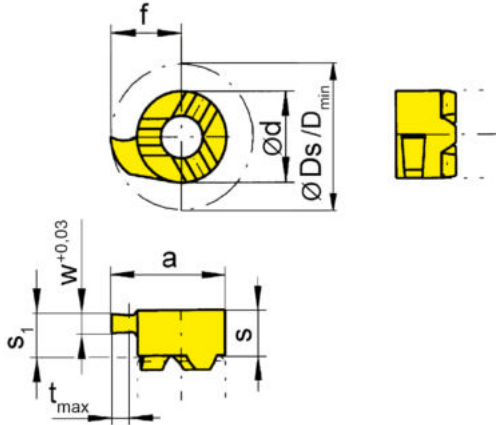
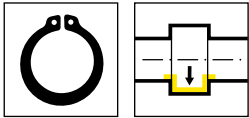

R = rechts wie gezeichnet
R = right hand version shown

L = links spiegelbildlich
L = left hand version

▲ ab Lager
on stock

HM-Sorten
Carbide grades
Δ 4 Wochen
4 weeks

Bestellnummer Part number	w	Nw	f	Ds	d	s	s ₁	a	t _{max}	D _{min}	Z	HIS	EG55	TH35	TN35	
R108.0070.00	0,74	0,7	4,8	9,6	6	3,6	3,2	7,8	1	8	1	306060R	▲	▲	▲	
R108.0080.00	0,84	0,8	4,8	9,6	6	3,6	3,2	7,8	1	8	1	306060R	▲	▲	▲	
R108.0090.00	0,94	0,9	4,8	9,6	6	3,6	3,2	7,8	1	8	1	306060R	▲	▲	▲	
L108.0070.00	0,74	0,7	4,8	9,6	6	3,6	3,2	7,8	1	8	1	306060L	Δ	▲	▲	
L108.0080.00	0,84	0,8	4,8	9,6	6	3,6	3,2	7,8	1	8	1	306060L	Δ	Δ	▲	
L108.0090.00	0,94	0,9	4,8	9,6	6	3,6	3,2	7,8	1	8	1	306060L	Δ	▲	▲	
Zapfenausführung not face cutting, limited depth of cut													P	●	●	●
													M	○	●	●
													K	○	●	●
													N	-	●	●
													S	-	●	●
													H	-	-	-

B

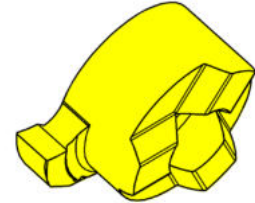
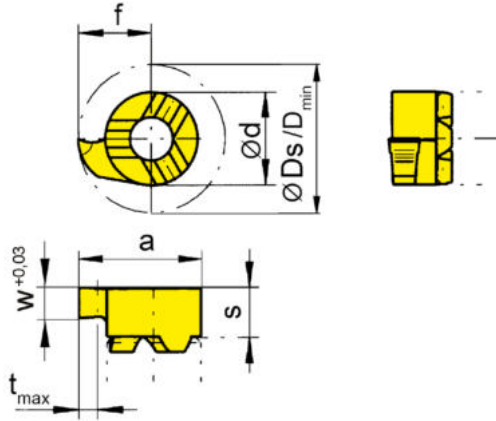
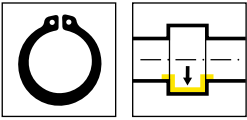

R = rechts wie gezeichnet
R = right hand version shown

L = links spiegelbildlich
L = left hand version

▲ ab Lager
on stock

HM-Sorten
Carbide grades
Δ 4 Wochen
4 weeks

Bestellnummer Part number	w	Nw	s	f	Ds	a	d	t _{max}	D _{min}	Z	HIS	MG12	EG55	TH35	TN35
R108.0110.00	1,19	1,1	3,2	4,8	9,6	7,8	6	1	8	1	306060R	▲	▲	▲	▲
R108.0130.00	1,39	1,3	3,2	4,8	9,6	7,8	6	1	8	1	306060R	▲	▲	▲	▲
R108.0160.00	1,69	1,6	3,2	4,8	9,6	7,8	6	1	8	1	306060R	▲	Δ	▲	▲
L108.0110.00	1,19	1,1	3,2	4,8	9,6	7,8	6	1	8	1	306060L	▲	Δ	▲	▲
L108.0130.00	1,39	1,3	3,2	4,8	9,6	7,8	6	1	8	1	306060L			Δ	▲
L108.0160.00	1,69	1,6	3,2	4,8	9,6	7,8	6	1	8	1	306060L			▲	Δ
P	o	•	•	•											
M	-	o	•	•											
K	-	o	•	•											
N	-	-	•	•											
S	-	-	•	•											
H	-	-	-	-											

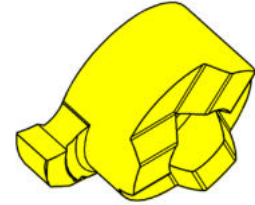
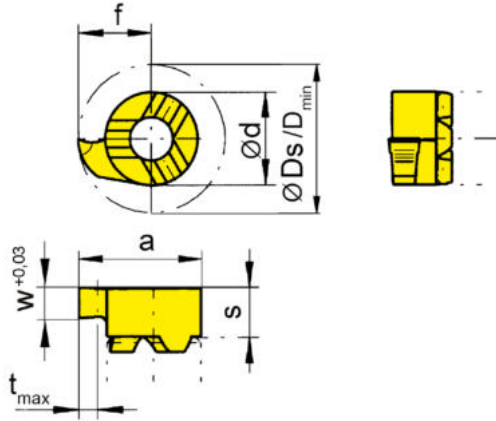
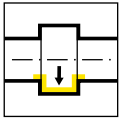

R = rechts wie gezeichnet
R = right hand version shown

L = links spiegelbildlich
L = left hand version

▲ ab Lager
on stock

HM-Sorten
Carbide grades
Δ 4 Wochen
4 weeks

Bestellnummer Part number	w	s	f	Ds	a	d	t _{max}	D _{min}	Z	HIS	MG12	EG55	TH35	TN35
R108.0150.00	1,5	3,2	4,8	9,6	7,8	6	1	8	1	306060R	▲	▲	▲	▲
R108.0200.00	2	3,2	4,8	9,6	7,8	6	1	8	1	306060R	▲	▲	▲	▲
L108.0150.00	1,5	3,2	4,8	9,6	7,8	6	1	8	1	306060L	▲		Δ	▲
L108.0200.00	2	3,2	4,8	9,6	7,8	6	1	8	1	306060L	▲		▲	▲
P	o	•	•	•										
M	-	o	•	•										
K	-	o	•	•										
N	-	-	•	•										
S	-	-	•	•										
H	-	-	-	-										

B

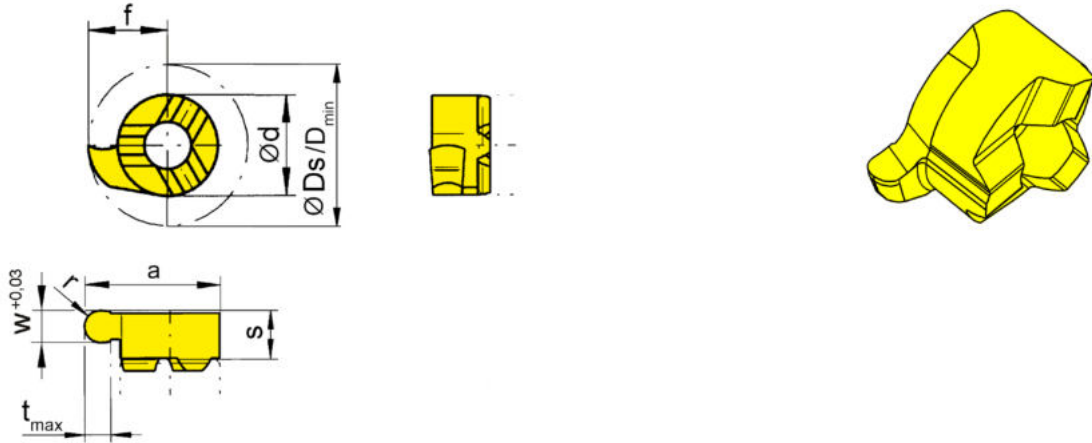
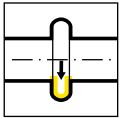

R = rechts wie gezeichnet
R = right hand version shown

L = links spiegelbildlich
L = left hand version

▲ ab Lager
on stock

△ 4 Wochen
4 weeks

HM-Sorten
Carbide grades

Bestellnummer Part number	w	s	f	Ds	a	r	d	t _{max}	D _{min}	Z	HIS	MG12	EG55	TH35	TI25	TN35
R108.0004.08	0,8	3,2	4,8	9,6	7,8	0,4	6	1	8	1	306060R	▲	▲	▲		▲
R108.0006.12	1,2	3,2	4,8	9,6	7,8	0,6	6	1	8	1	306060R	▲	▲	▲		▲
R108.0009.18	1,8	3,2	4,8	9,6	7,8	0,9	6	1	8	1	306060R	▲	▲	▲	▲	▲
L108.0004.08	0,8	3,2	4,8	9,6	7,8	0,4	6	1	8	1	306060L	△	▲	▲		▲
L108.0006.12	1,2	3,2	4,8	9,6	7,8	0,6	6	1	8	1	306060L	▲	▲	▲		▲
L108.0009.18	1,8	3,2	4,8	9,6	7,8	0,9	6	1	8	1	306060L	△		▲	△	▲
P	o	•	•	•	•	•	•	•	•	•						
M	-	o	•	•	•	•	•	•	•	•						
K	-	o	•	•	•	•	•	•	•	•						
N	-	-	•	•	•	•	•	•	•	•						
S	-	-	•	•	•	•	•	•	•	•						
H	-	-	-	-	-	-	-	-	-	-						

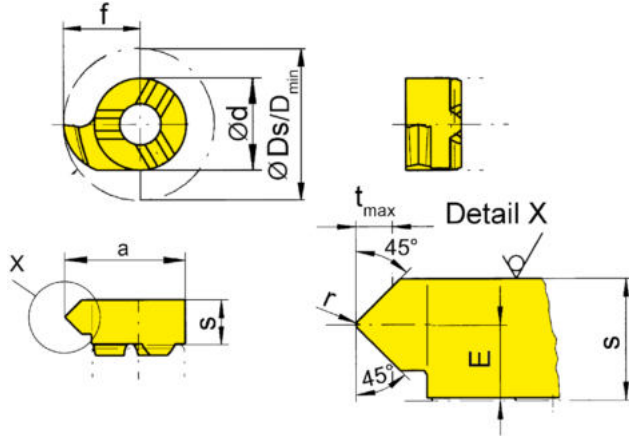
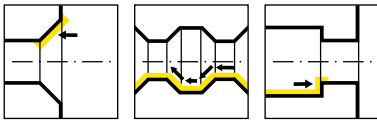

R = rechts wie gezeichnet
R = right hand version shown

L = links spiegelbildlich
L = left hand version

HM-Sorten
Carbide grades
▲ ab Lager
on stock
Δ 4 Wochen
4 weeks

Bestellnummer Part number	E	f	Ds	r	d	s	a	D _{min}	α	t _{max}	Z	HIS	EG55	TA45	TI25	TN35
R108.4545.02	1,8	4,65	9,3	0,2	6	3,6	7,65	7,8	45°	1,4	1	306060R	▲	▲	▲	▲
L108.4545.02	1,8	4,65	9,3	0,2	6	3,6	7,65	7,8	45°	1,4	1	306060L	▲	Δ	Δ	▲
P	●	●	●	●	●	●	●	●	●	●	●	●	●	●	●	●
M	○	●	●	●	●	●	●	●	●	●	●	●	●	●	●	●
K	○	●	●	●	●	●	●	●	●	●	●	●	●	●	●	●
N	-	●	●	●	●	●	●	●	●	●	●	●	●	●	●	●
S	-	●	●	●	●	●	●	●	●	●	●	●	●	●	●	●
H	-	-	-	-	-	-	-	-	-	-	-	-	-	-	-	-

B



Abbildung = rechtsschneidend
Picture = right hand cutting version

HM-Sorten
Carbide grades
▲ ab Lager
on stock
Δ 4 Wochen
4 weeks

Bestellnummer Part number	Ds	Nw	w	s	s ₁	t _{max}	Z	HIS	TA45
306.0050.10.00	9,7	0,5	0,57	3,4	3,2	0,85	3	306060R	▲
306.0070.10.00	9,7	0,7	0,77	3,4	3,2	1,15	3	306060R	▲

Zapfenausführung
not face cutting,
limited depth of cut

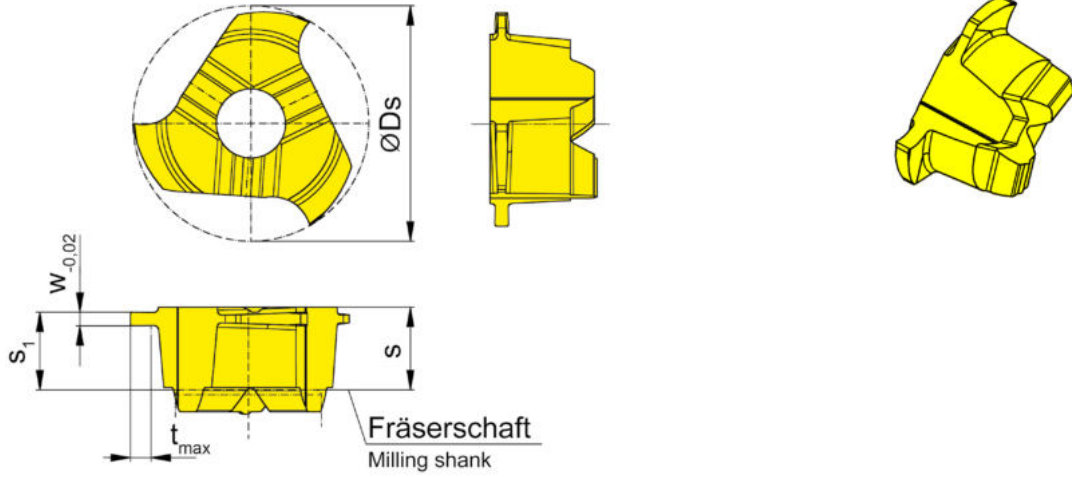
P	●
M	●
K	●
N	●
S	●
H	-



Abbildung = rechtsschneidend
Picture = right hand cutting version

HM-Sorten
Carbide grades
▲ ab Lager
on stock
Δ 4 Wochen
4 weeks

Bestellnummer Part number	Ds	Nw	w	t ₁	s	s ₁	t _{max}	Z	HIS	AS45
306.1105.30	11,7	1,1	1,21	0,47	3,4	2,7	0,5	3	306060R	▲
306.1307.30	11,7	1,3	1,41	0,65	3,4	2,6	0,7	3	306060R	▲
										P ●
										M ●
										K ●
										N o
										S ●
										H -

B

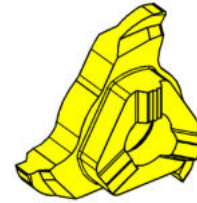
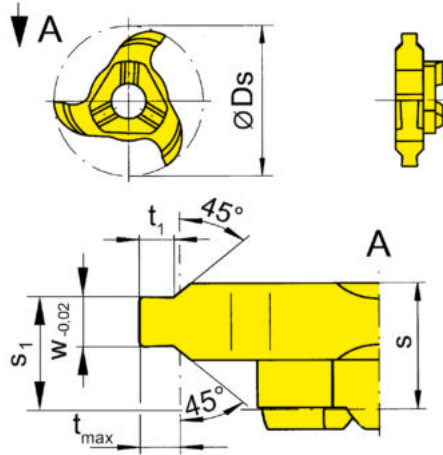

z3



Abbildung = rechtsschneidend
Picture = right hand cutting version

▲ ab Lager
on stock

HM-Sorten
Carbide grades
Δ 4 Wochen
4 weeks

Bestellnummer Part number	Ds	Nw	w	s	t _{max}	Z	HIS	AS45	TA45
306.0080.10.00	9,7	0,8	0,87	3,2	1,5	3	306060R		▲
306.0090.10.00	9,7	0,9	0,97	3,2	1,5	3	306060R		▲
306.0100.10.00	9,7	1	1,07	3,2	1,5	3	306060R		▲
306.0110.10.00	9,7	1,1	1,21	3,2	1,5	3	306060R		▲
306.0130.10.00	9,7	1,3	1,41	3,2	1,5	3	306060R	▲	▲
306.0160.10.00	9,7	1,6	1,71	3,2	1,5	3	306060R	▲	▲
								P	● ●
								M	● ●
								K	● ●
								N	○ ●
								S	● ●
								H	- -

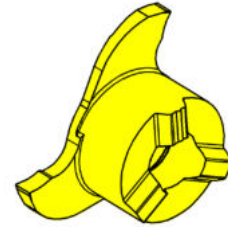
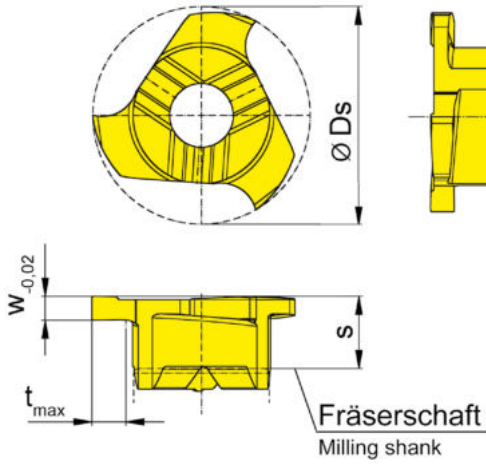
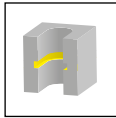

Abbildung = rechtsschneidend
Picture = right hand cutting version

▲ ab Lager
on stock

HM-Sorten
Carbide grades

Δ 4 Wochen
4 weeks

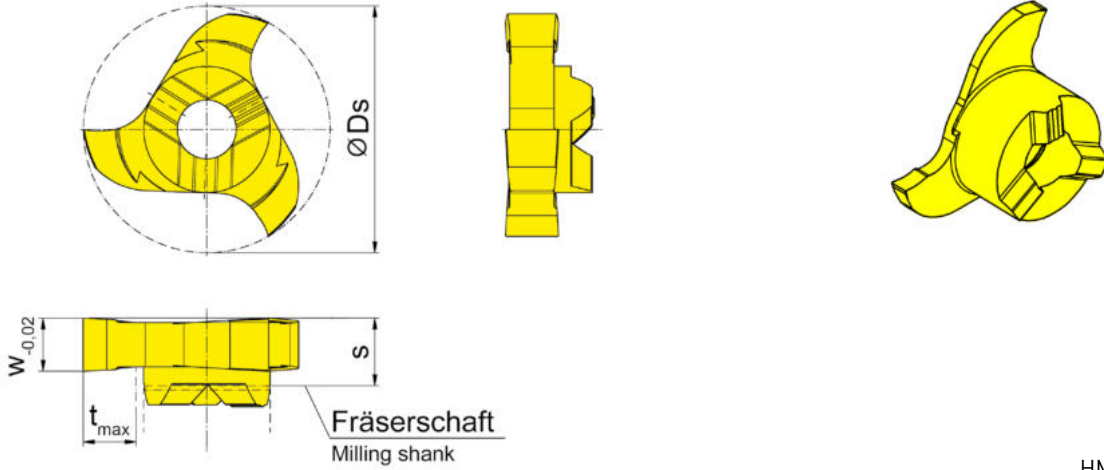
Bestellnummer Part number	Ds	Nw	w	s	t _{max}	Z	HIS	MG12	TF45	TN35
306.0110.00	11,7	1,1	1,21	3,2	2,5	3	306060R	▲	▲	▲
306.0130.00	11,7	1,3	1,41	3,2	2,5	3	306060R	Δ	Δ	▲
306.0160.00	11,7	1,6	1,71	3,2	2,5	3	306060R	Δ	Δ	▲
								P	o	•
								M	-	•
								K	-	•
								N	-	•
								S	-	•
								H	-	-

B



Abbildung = rechtsschneidend
Picture = right hand cutting version

HM-Sorten
Carbide grades
▲ ab Lager
on stock
Δ 4 Wochen
4 weeks

Bestellnummer Part number	Ds	Nw	w	s	t _{max}	Z	HIS	T125
306.0110.40	11,7	1,1	1,21	3,2	2,5	3	306060R	▲
306.0130.40	11,7	1,3	1,41	3,2	2,5	3	306060R	Δ
306.0160.40	11,7	1,6	1,71	3,2	2,5	3	306060R	▲
								P -
								M -
								K -
								N ●
								S -
								H -

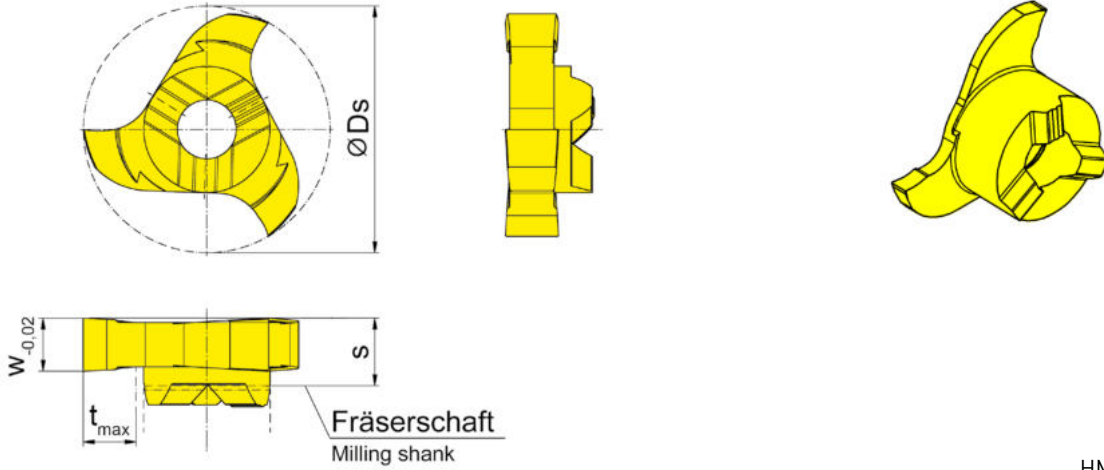
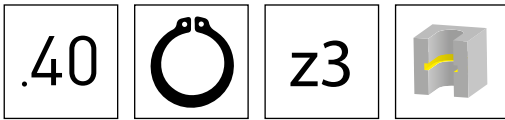
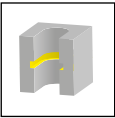

z3

B



Abbildung = rechtsschneidend
Picture = right hand cutting version

▲ ab Lager
on stock

HM-Sorten
Carbide grades
Δ 4 Wochen
4 weeks

Bestellnummer Part number	Ds	w	s	r	t _{max}	Z	HIS	AS45	TA45
306.0150.10.00	9,7	1,5	3,2	-	1,5	3	306060R	▲	▲
306.0200.10.00	9,7	2	3,2	0,2	1,5	3	306060R	▲	▲
								P ● ●	
								M ● ●	
								K ● ●	
								N ○ ●	
								S ● ●	
								H - -	

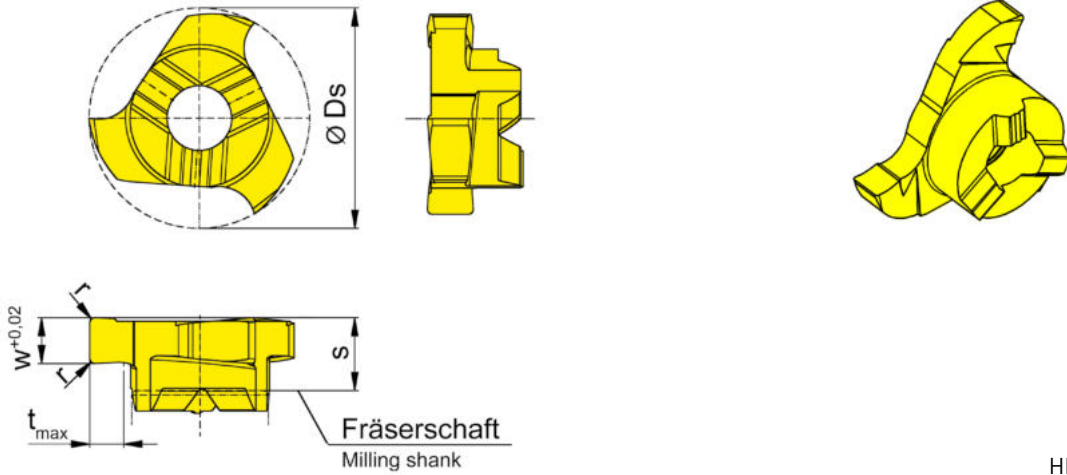
B

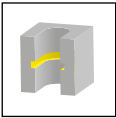

z3



Abbildung = rechtsschneidend
Picture = right hand cutting version

▲ ab Lager on stock
△ 4 Wochen 4 weeks
HM-Sorten
Carbide grades

Bestellnummer Part number	Ds	w	s	r	t _{max}	Z	HIS	HM-Sorten Carbide grades				
								MG12	AS45	TF45	TN35	
306.0100.1.00	11,7	1	3,2	-	2,5	3	306060R				▲	
306.0150.00	11,7	1,5	3,2	-	2,5	3	306060R	▲	▲	▲	▲	
306.0150.02	11,7	1,5	3,2	0,2	2,5	3	306060R		▲			
306.0200.00	11,7	2	3,2	0,2	2,5	3	306060R	▲	▲	▲	▲	
306.0250.00	11,7	2,5	3,2	0,2	2,5	3	306060R	▲	▲	▲	▲	
306.0300.00	11,7	3	4,2	0,2	2,5	3	306060R		▲		▲	
								P	o	•	•	•
								M	-	•	•	•
								K	-	•	•	•
								N	-	o	•	•
								S	-	•	•	•
								H	-	-	-	-

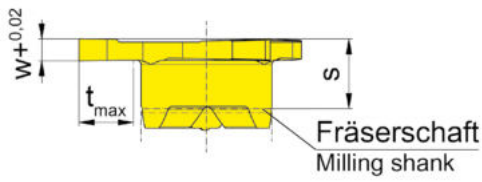
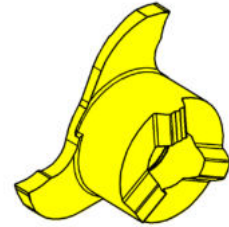
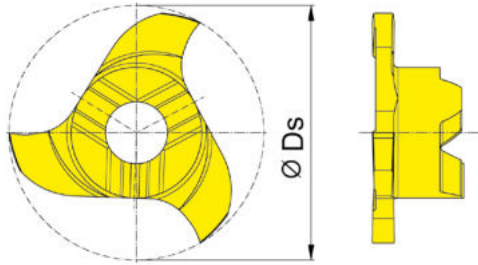

Abbildung = rechtsschneidend
Picture = right hand cutting version

HM-Sorten
Carbide grades
▲ ab Lager
on stock
Δ 4 Wochen
4 weeks

Bestellnummer Part number	Ds	w	s	r	t _{max}	Z	HIS	Ti25
306.0150.40	11,7	1,5	3,2	-	2,5	3	306060R	▲
306.0200.40	11,7	2	3,2	0,2	2,5	3	306060R	▲
306.0250.40	11,7	2,5	3,2	0,2	2,5	3	306060R	▲
								P -
								M -
								K -
								N ●
								S -
								H -

B

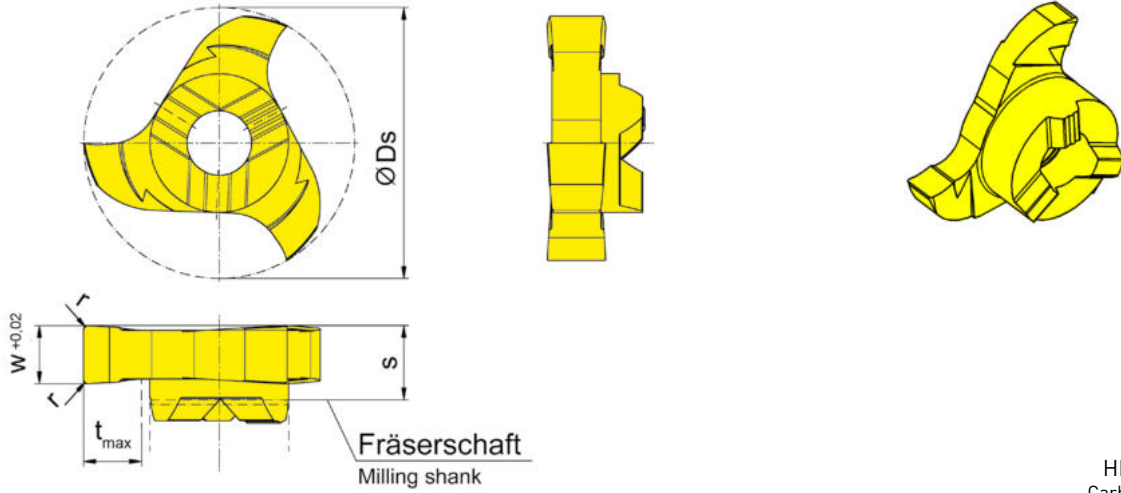

Abbildung = rechtsschneidend
Picture = right hand cutting version

▲ ab Lager
on stock

HM-Sorten
Carbide grades

Δ 4 Wochen
4 weeks

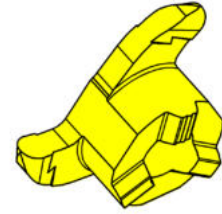
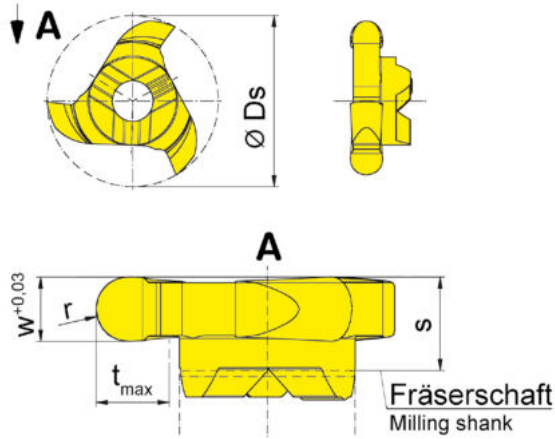
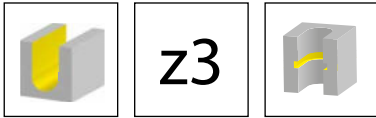
Bestellnummer Part number	Ds	w	s	r	t _{max}	Z	HIS	MG12	AN25	AS45	RC45	TF45	TI25	TN35
306.0005.10	11,7	1	3,2	0,5	2,5	3	306060R		▲		▲			
306.0007.15	11,7	1,5	3,2	0,75	2,5	3	306060R			▲				
306.0010.20	11,7	2	3,2	1	2,5	3	306060R			▲				
306.0011.22	11,7	2,2	3,2	1,1	2,5	3	306060R	Δ		▲		Δ	▲	▲
306.0015.30	11,7	3	4,2	1,5	2,5	3	306060R			▲				
P	o	•	•	•	•	•	•	•	•	•	•	•	•	•
M	-	o	•	•	•	•	•	•	•	•	•	•	•	•
K	-	-	•	•	•	•	•	•	•	•	•	•	•	•
N	-	-	o	-	•	•	•	•	•	•	•	•	•	•
S	-	-	•	-	•	•	•	•	•	•	•	•	•	•
H	-	-	-	-	-	-	-	-	-	-	-	-	-	-



Abbildung = rechtsschneidend
Picture = right hand cutting version

HM-Sorten
Carbide grades
▲ ab Lager
on stock
Δ 4 Wochen
4 weeks

Bestellnummer Part number	Ds	E	s	w	Form	t _{max}	Z	HIS	MG12	TF45	TI25	TN35
306.4545.00	11,7	1,1	3,4	1,2	A	0,8	3	306060R	▲	▲	▲	▲
306.4593.20	9,3	1,6	3,4	0,2	B	1,4	3	306060R			▲	
									P	o	•	•
									M	-	•	•
									K	-	•	•
									N	-	•	•
									S	-	•	•
									H	-	-	-

B

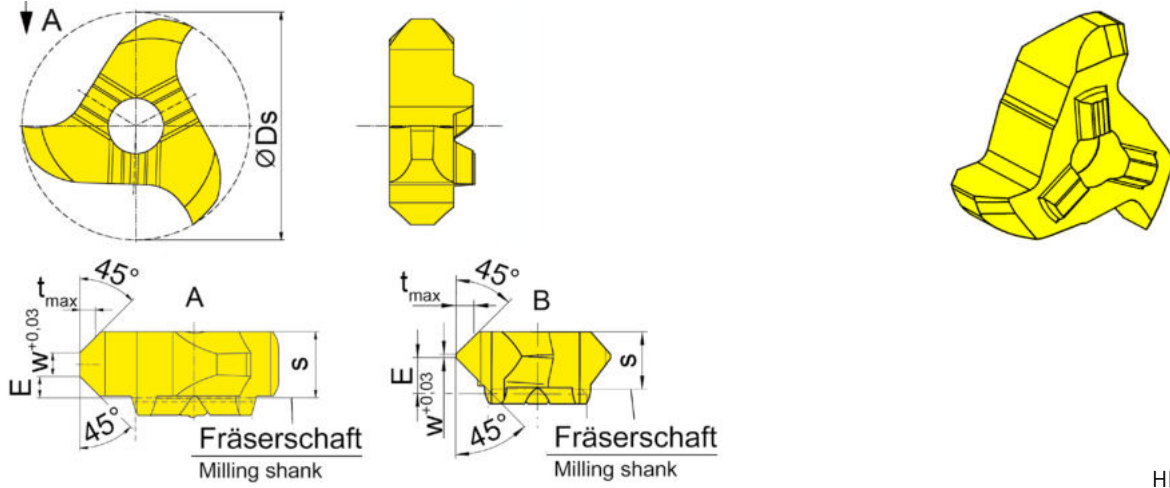
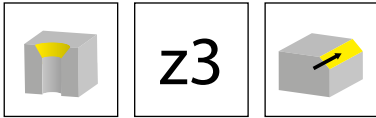

z6



Abbildung = rechtsschneidend
Picture = right hand cutting version

▲ ab Lager
on stock

HM-Sorten
Carbide grades
Δ 4 Wochen
4 weeks

Bestellnummer Part number	Ds	Nw	w	s	t _{max}	Z	HIS	HM-Sorten Carbide grades	
								AS45	TA45
606.0110.00	11,7	1,1	1,21	3,5	2,5	6	306060R	▲	▲
606.0130.00	11,7	1,3	1,41	3,5	2,5	6	306060R	▲	▲
606.0160.00	11,7	1,6	1,71	3,5	2,5	6	306060R	▲	▲
								P	● ●
								M	● ●
								K	● ●
								N	o ●
								S	● ●
								H	- -

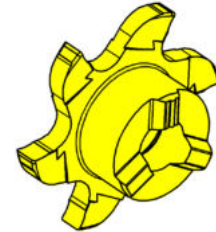
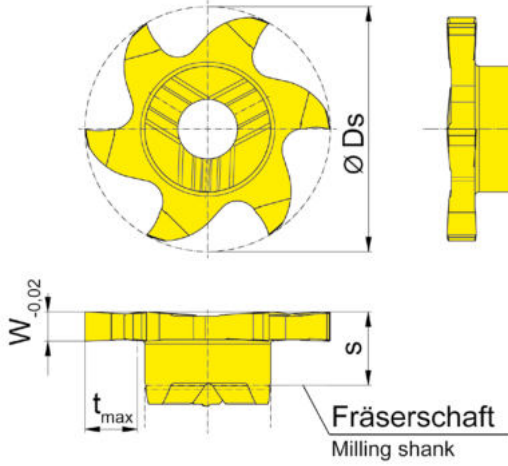
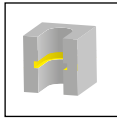
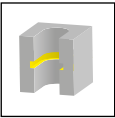

z6

B



Abbildung = rechtsschneidend
Picture = right hand cutting version

▲ ab Lager
on stock

HM-Sorten
Carbide grades

△ 4 Wochen
4 weeks

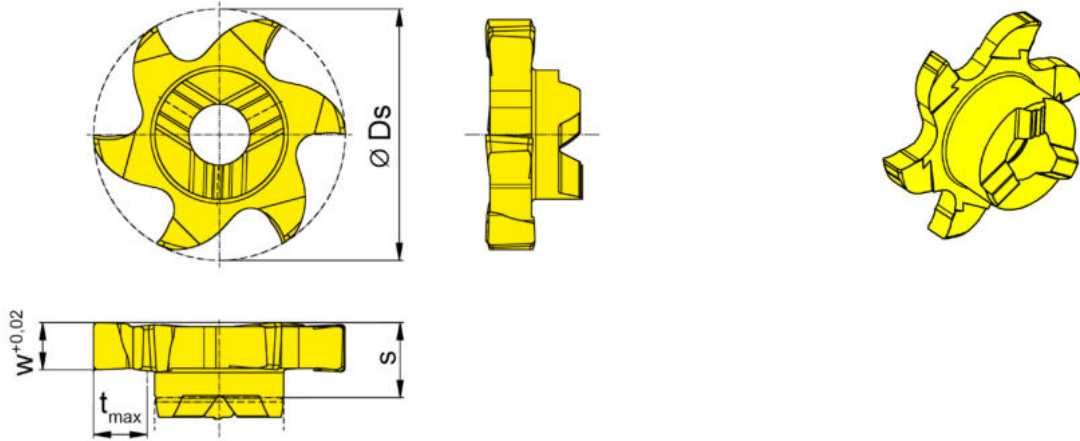
Bestellnummer Part number	Ds	w	s	t _{max}	Z	HIS	AS45	EG35	IG35	TA45
606.0025.00	11,7	0,25	3,5	2,5	6	306060R		▲	△	
606.0030.00	11,7	0,3	3,5	2,5	6	306060R		▲	△	
606.0040.00	11,7	0,4	3,5	2,5	6	306060R		▲	△	
606.0050.00	11,7	0,5	3,5	2,5	6	306060R		▲	△	
606.0060.00	11,7	0,6	3,5	2,5	6	306060R		▲	△	
606.0070.00	11,7	0,7	3,5	2,5	6	306060R		▲	△	
606.0080.00	11,7	0,8	3,5	2,5	6	306060R		▲	△	
606.0090.00	11,7	0,9	3,5	2,5	6	306060R		▲	△	
606.0100.00	11,7	1	3,5	2,5	6	306060R		▲	△	
606.0150.00	11,7	1,5	3,5	2,5	6	306060R	▲			▲
606.0200.00	11,7	2	3,5	2,5	6	306060R	▲			▲
606.0250.00	11,7	2,5	3,5	2,5	6	306060R	▲			▲
P	●	●	-	●						
M	●	●	●	●						
K	●	○	-	●						
N	○	-	-	●						
S	●	-	●	●						
H	-	-	-	-						

B



Abbildung = rechtsschneidend
Picture = right hand cutting version

▲ ab Lager
on stock

△ 4 Wochen
4 weeks

Bestellnummer Part number	Ds	E	s	w	a	b	Z	HIS	TA45
606.1515.20	11,7	1,9	3,7	0,2	15°	1,5	6	306060R	△
606.2020.20	11,7	1,9	3,7	0,2	20°	1,5	6	306060R	▲
606.3030.20	11,7	1,9	3,7	0,2	30°	1,5	6	306060R	▲
606.4545.20	11,7	1,9	3,7	0,2	45°	1,1	6	306060R	▲
									P ●
									M ●
									K ●
									N ●
									S ●
									H -

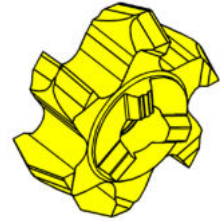
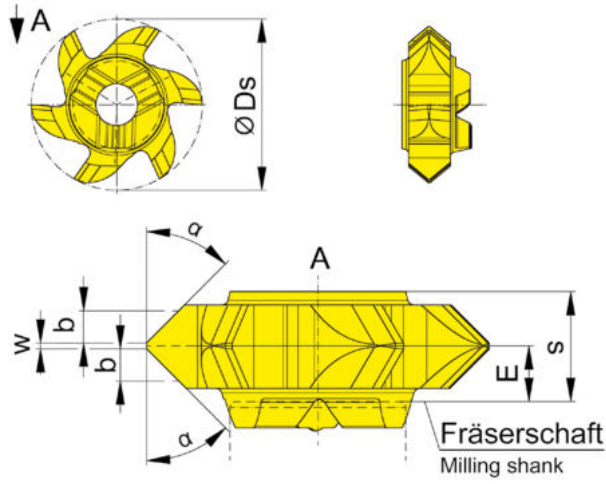
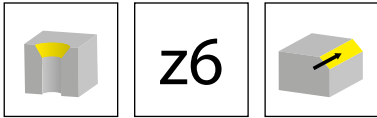

Abbildung = rechtsschneidend
Picture = right hand cutting version

HM-Sorten
Carbide grades
▲ ab Lager
on stock
Δ 4 Wochen
4 weeks

Bestellnummer Part number	Ds	E	s	t _{max}	Z	HIS	AS45
606.6060.05	11,7	1,9	3,75	2	6	306060R	▲
							P ●
							M ●
							K ●
							N ○
							S ●
							H -

B

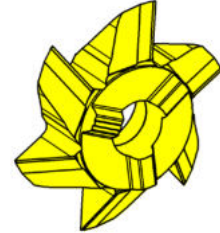
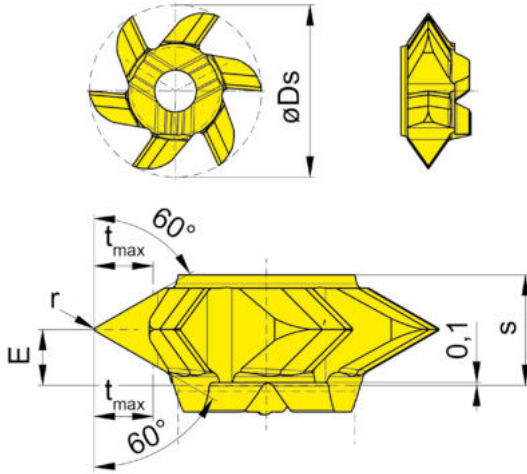
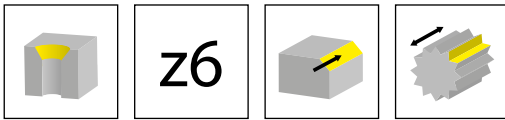
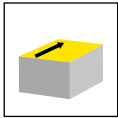

z6



Abbildung = rechtsschneidend
Picture = right hand cutting version

▲ ab Lager
on stock

HM-Sorten
Carbide grades
Δ 4 Wochen
4 weeks

Bestellnummer Part number	D_s	Z	r	t_{max}	s	HIS	AS45	TI25
606.PLT6.08	11,7	6	0,8	3,2	3,6	306060R	▲	▲
							P ● ●	● ●
							M ● ●	● ●
							K ● ●	● ●
							N ○ ●	● ●
							S ● ●	● ●
							H - -	- -

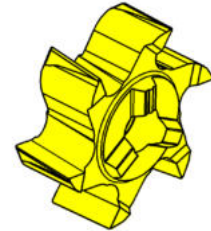
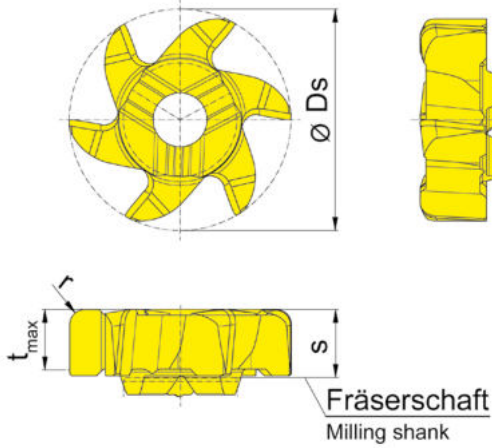
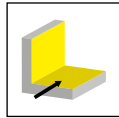
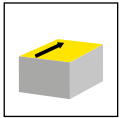

z6



Abbildung = rechtsschneidend
Picture = right hand cutting version

▲ ab Lager
on stock

HM-Sorten
Carbide grades

△ 4 Wochen
4 weeks

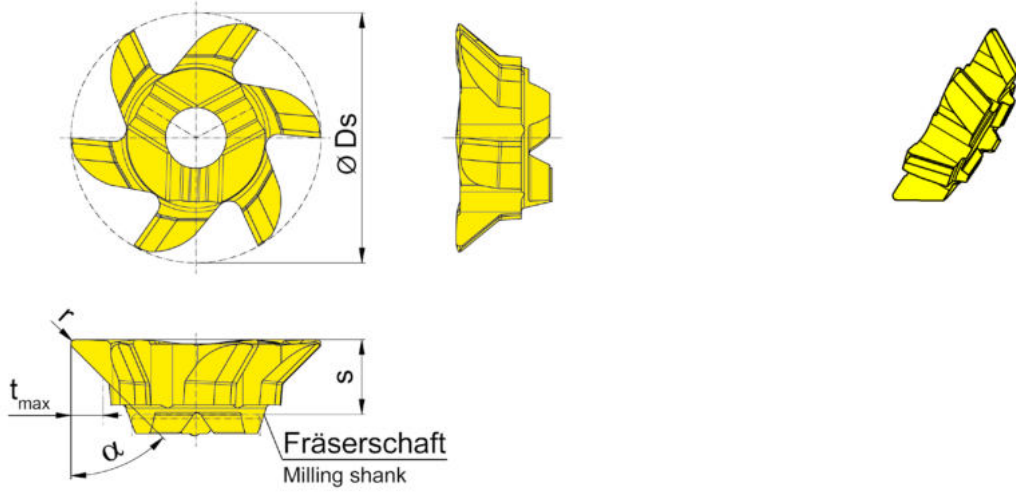
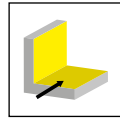
Bestellnummer Part number	Ds	Z	r	α	t_{max}	s	HIS	AS45
606.0015.22	11,7	6	0,2	15°	0,7	3,5	306060R	▲
606.0030.22	11,7	6	0,2	30°	1,4	3,5	306060R	▲
606.0045.22	11,7	6	0,2	45°	1,5	3,5	306060R	▲
								P ●
								M ●
								K ●
								N ○
								S ●
								H -

Nutfräsen (zirkular)

Groove Milling by circular interpolation

B

Fräaserschaft
Milling shank
M308/M308.ST/M308.ER

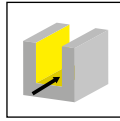

Seite/Page
68-71

Grundaufnahme
Basic Holder
WFB

Seite/Page
72

Einschraubfräser
Screw-in cutter
M308.M

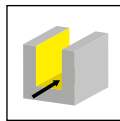

Seite/Page
73

Schneidplatte
Insert
111/308/608

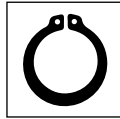

Seite/Page
74-75, 79-81

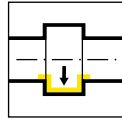

Seite/Page
76

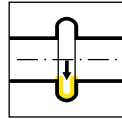

Seite/Page
77

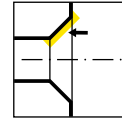

Seite/Page
78

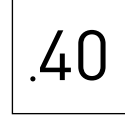

Seite/Page
81, 83

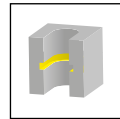

Seite/Page
82, 86

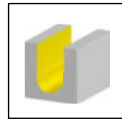

Seite/Page
84

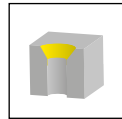

Seite/Page
85, 87

M308



**Fräser mit wechselbarer
Schneidplatte**

ab Bohrung \varnothing 13,7 mm

**Milling shank with
exchangeable insert**

from bore \varnothing 13,7 mm

B

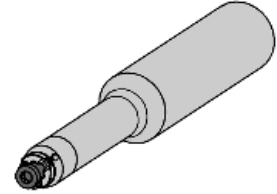
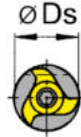
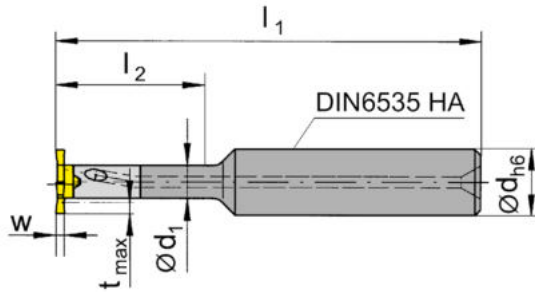
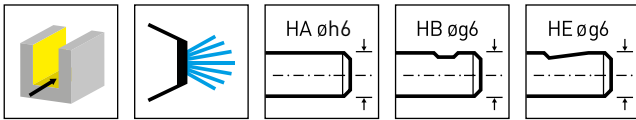

Bestellnummer Part number	d	l ₁	l ₂	d ₁	Form	HWS
M308.0012.01A	12	95	29	8	A	308080R • 308080L
M308.0012.02A	12	110	42	8	A	308080R • 308080L
M308.0012.03A	12	120	56	8	A	308080R • 308080L
M308.0012.07A	12	160	-	8	A	308080R • 308080L
M308.0012.01B	12	95	29	8	B	308080R • 308080L
M308.0012.02B	12	110	42	8	B	308080R • 308080L
M308.0012.03B	12	120	56	8	B	308080R • 308080L
M308.0012.01E	12	95	29	8	E	308080R • 308080L
M308.0012.02E	12	110	42	8	E	308080R • 308080L
M308.0012.03E	12	120	56	8	E	308080R • 308080L

w, Ds, tmax siehe Schneidplatte
w, Ds, tmax see inserts

Ersatzteile

Spare Parts

Fräuserschaft Milling shank	Spannschraube Clamping Screw	TORX PLUS®-Schlüssel TORX PLUS® Wrench
M308...	3.5.12T10EP	T10PL

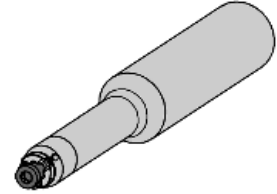
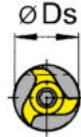
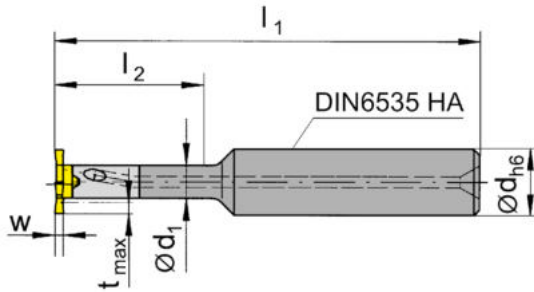
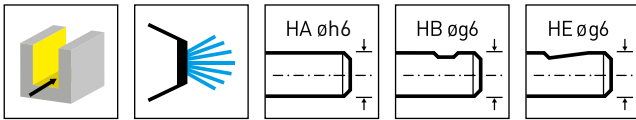

Bestellnummer Part number	d	l ₁	l ₂	d ₁	Form	HWS
M308.1012.02A	12	110	42	9,5	A	308080R • 308080L
M308.1016.01A	16	110	33	9,5	A	308080R • 308080L
M308.1016.02A	16	110	45	9,5	A	308080R • 308080L
M308.1016.03A	16	130	64	9,5	A	308080R • 308080L
M308.1012.02B	12	110	42	9,5	B	308080R • 308080L
M308.1016.01B	16	110	33	9,5	B	308080R • 308080L
M308.1016.02B	16	110	45	9,5	B	308080R • 308080L
M308.1016.03B	16	130	64	9,5	B	308080R • 308080L
M308.1012.02E	12	110	42	9,5	E	308080R • 308080L
M308.1016.01E	16	110	33	9,5	E	308080R • 308080L
M308.1016.02E	16	110	45	9,5	E	308080R • 308080L
M308.1016.03E	16	130	64	9,5	E	308080R • 308080L

w, Ds, tmax siehe Schneidplatte
w, Ds, tmax see inserts

Ersatzteile
Spare Parts

Frärschaft Milling shank	Spannschraube Clamping Screw	TORX PLUS®-Schlüssel TORX PLUS® Wrench
M308...	3.5.12T10EP	T10PL

Frälerschaft

Milling shank

M308.ST



B

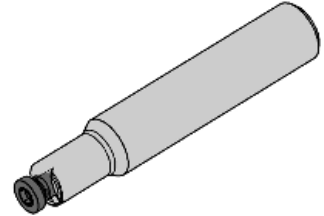
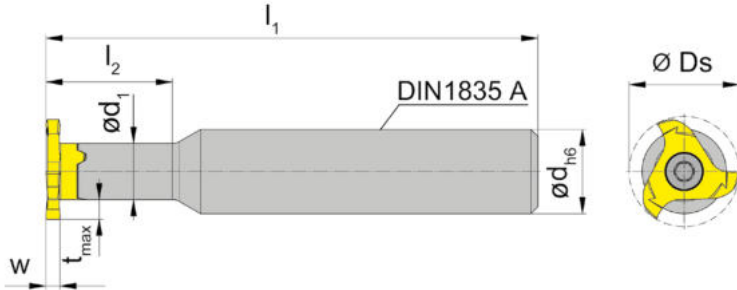
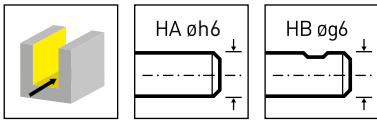

Bestellnummer Part number	d	l ₁	l ₂	d ₁	Form	HWS
M308.ST10.01A	10	60	18	8	A	308080R • 308080L
M308.ST12.01A	12	70	18	8	A	308080R • 308080L
M308.ST13.01A	13	70	26	8	A	308080R • 308080L
M308.ST10.01B	10	60	18	8	B	308080R • 308080L
M308.ST12.01B	12	70	18	8	B	308080R • 308080L

w, Ds, tmax siehe Schneidplatte
w, Ds, tmax see inserts

Ersatzteile

Spare Parts

Frälerschaft Milling shank	Spannschraube Clamping Screw	TORX PLUS®-Schlüssel TORX PLUS® Wrench
M308...	3.5.12T10EP	T10PL

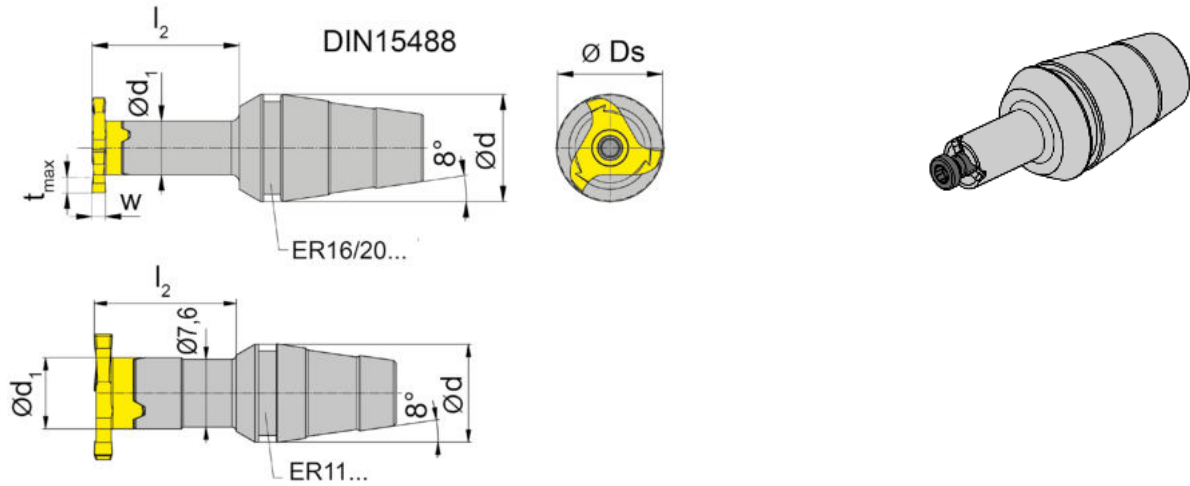
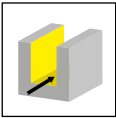

Bestellnummer Part number	d	l ₂	d ₁	Spannmutter Clamping nut	HWS
M308.ER11.02	11	16	8	ER11.6499	308080R • 308080L
M308.ER16.02	16	22	8	ER16.6499/ERM16.6499	308080R • 308080L
M308.ER20.02	20	22	8	ER20.6499/ERM20.6499	308080R • 308080L

w, Ds, tmax siehe Schneidplatte
w, Ds, tmax see inserts

Spannmutter ist nicht im Lieferumfang enthalten - bitte separat bestellen!
Clamping nut is not combined with milling shank - separate order required!

Ersatzteile
Spare Parts

Frälerschaft Milling shank	Spannschraube Clamping Screw	TORX PLUS®-Schlüssel TORX PLUS® Wrench
M308...	3.5.12T10EP	T10PL

B

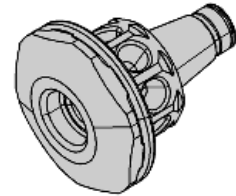
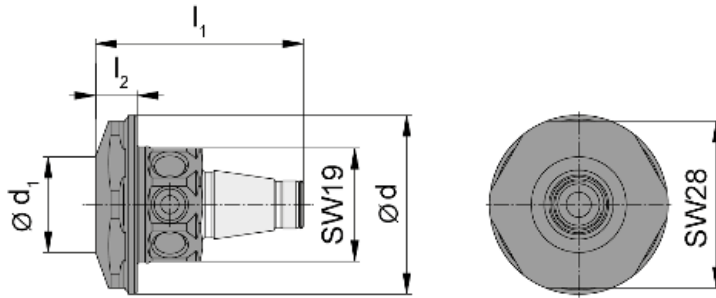

Bestellnummer Part number	l_1	l_2	d_1	d
WFB.2012.M081.01	35	7	16	30

für Einschraubfräser
for Screw-in cutter

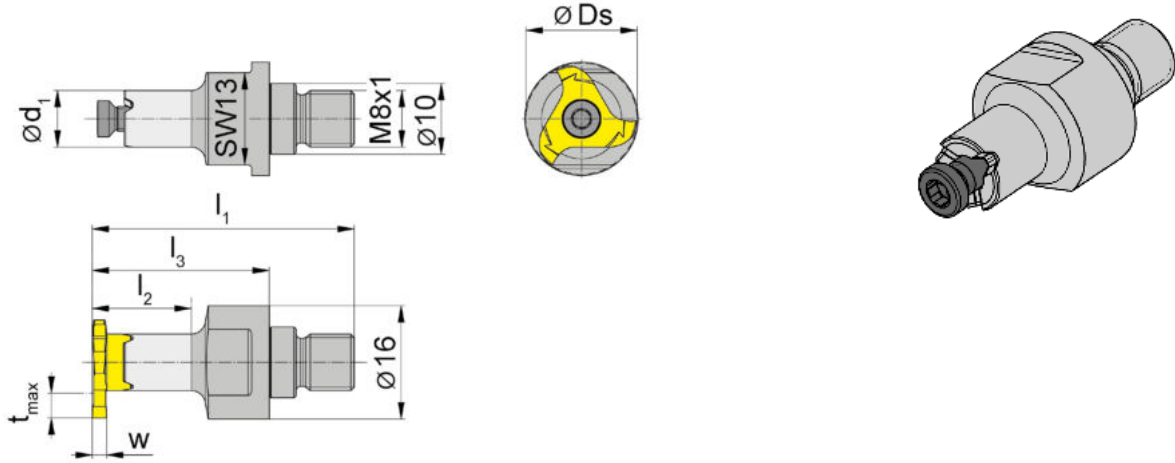

Bestellnummer Part number	l_1	l_2	l_3	d_1	SW	HWS	HMS
M308.M081.01	37	14	25	8	13	308080R • 308080L	8201

w, D_s , t_{max} siehe Schneidplatte
w, D_s , t_{max} see inserts

Ersatzteile
Spare Parts

Einschraubfräser Screw-in cutter	Spannschraube Clamping Screw	TORX PLUS®-Schlüssel TORX PLUS® Wrench
M308.M081.01	3.5.12T10EP	T10PL

B

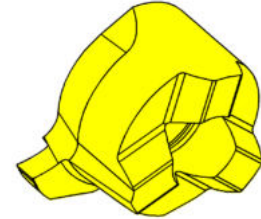
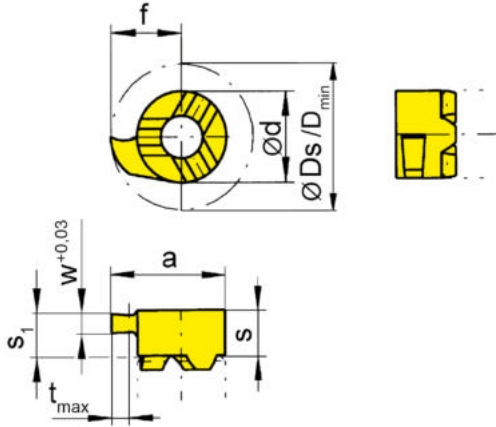
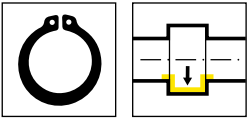

R = rechts wie gezeichnet
R = right hand version shown

L = links spiegelbildlich
L = left hand version

▲ ab Lager
on stock

HM-Sorten
Carbide grades
△ 4 Wochen
4 weeks

Bestellnummer Part number	w	Nw	f	Ds	d	s	s ₁	a	t _{max}	D _{min}	Z	HIS	MG12	EG55	TH35	TN35	
R111.0070.00	0,74	0,7	6,7	13,4	8	4,15	3,95	10,7	1,2	11	1	308080R		▲	▲	▲	
R111.0080.00	0,84	0,8	6,7	13,4	8	4,15	3,95	10,7	1,3	11	1	308080R		▲	▲	▲	
R111.0090.00	0,94	0,9	6,7	13,4	8	4,15	3,95	10,7	1,5	11	1	308080R	▲	▲	▲	▲	
L111.0070.00	0,74	0,7	6,7	13,4	8	4,15	3,95	10,7	1,2	11	1	308080L			△	▲	
L111.0080.00	0,84	0,8	6,7	13,4	8	4,15	3,95	10,7	1,3	11	1	308080L			△	▲	
L111.0090.00	0,94	0,9	6,7	13,4	8	4,15	3,95	10,7	1,5	11	1	308080L	▲		▲	▲	
Zapfenausführung not face cutting, limited depth of cut													P	o	•	•	•
													M	-	o	•	•
													K	-	o	•	•
													N	-	-	•	•
													S	-	-	•	•
													H	-	-	-	-

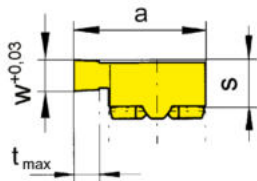
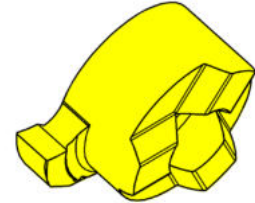
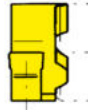
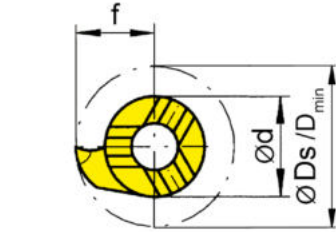
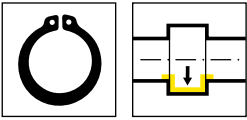

R = rechts wie gezeichnet
R = right hand version shown

L = links spiegelbildlich
L = left hand version

▲ ab Lager
on stock

HM-Sorten
Carbide grades
Δ 4 Wochen
4 weeks

Bestellnummer Part number	w	Nw	s	f	Ds	d	a	t _{max}	D _{min}	Z	HIS	MG12	EG55	TH35	TN35
R111.0110.00	1,19	1,1	3,95	6,7	13,4	8	10,7	2,3	11	1	308080R	▲	▲	▲	▲
R111.0130.00	1,39	1,3	3,95	6,7	13,4	8	10,7	2,3	11	1	308080R	▲	▲	▲	▲
R111.0160.00	1,69	1,6	3,95	6,7	13,4	8	10,7	2,3	11	1	308080R	▲	▲	▲	▲
L111.0110.00	1,19	1,1	3,95	6,7	13,4	8	10,7	2,3	11	1	308080L	▲	▲	▲	▲
L111.0130.00	1,39	1,3	3,95	6,7	13,4	8	10,7	2,3	11	1	308080L	Δ	Δ	▲	▲
L111.0160.00	1,69	1,6	3,95	6,7	13,4	8	10,7	2,3	11	1	308080L	Δ	▲	▲	▲
												P	o	•	•
												M	-	o	•
												K	-	o	•
												N	-	-	•
												S	-	-	•
												H	-	-	-

B

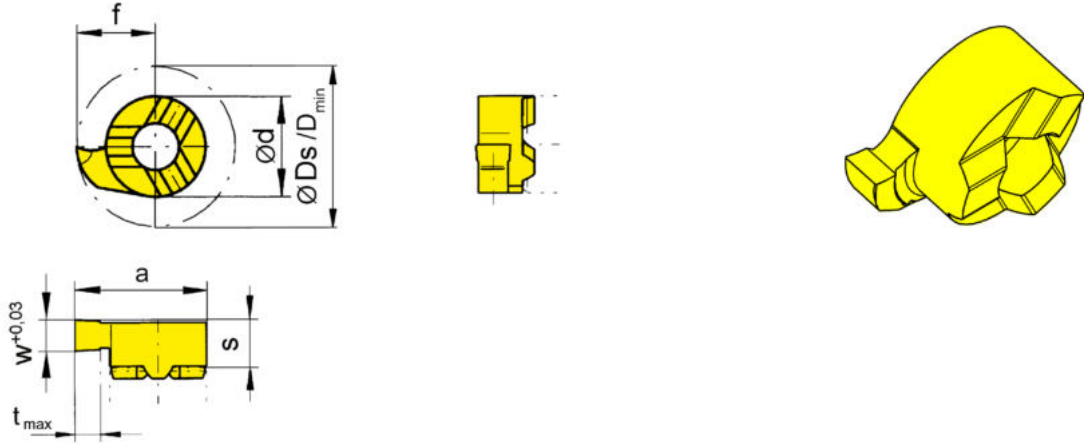
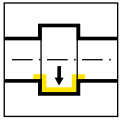

R = rechts wie gezeichnet
R = right hand version shown

L = links spiegelbildlich
L = left hand version

▲ ab Lager
on stock

△ 4 Wochen
4 weeks

HM-Sorten
Carbide grades

Bestellnummer Part number	w	s	f	Ds	d	a	t _{max}	D _{min}	Z	HIS	MG12	EG55	TH35	TN35
R111.0150.00	1,5	3,95	6,7	13,4	8	10,7	2,3	11	1	308080R	▲	▲	▲	▲
R111.0200.00	2	3,95	6,7	13,4	8	10,7	2,3	11	1	308080R	▲	▲	▲	▲
R111.0250.00	2,5	3,95	6,7	13,4	8	10,7	2,3	11	1	308080R	▲	▲	▲	▲
R111.0300.00	3	3,95	6,7	13,4	8	10,7	2,3	11	1	308080R	▲	▲	▲	▲
L111.0150.00	1,5	3,95	6,7	13,4	8	10,7	2,3	11	1	308080L	▲	▲	▲	▲
L111.0200.00	2	3,95	6,7	13,4	8	10,7	2,3	11	1	308080L	▲	▲	▲	▲
L111.0250.00	2,5	3,95	6,7	13,4	8	10,7	2,3	11	1	308080L	▲	▲	▲	▲
L111.0300.00	3	3,95	6,7	13,4	8	10,7	2,3	11	1	308080L	▲	▲	▲	▲
P	o	•	•	•										
M	-	o	•	•										
K	-	o	•	•										
N	-	-	•	•										
S	-	-	•	•										
H	-	-	-	-										

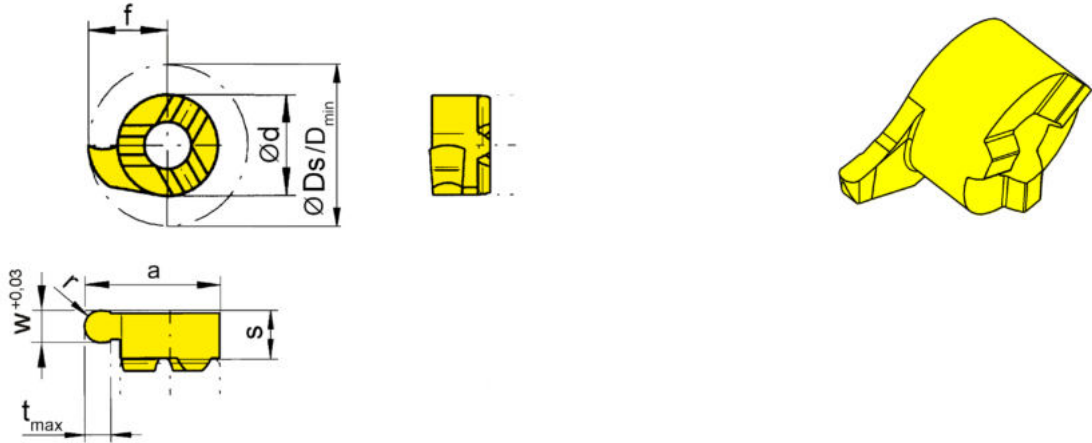
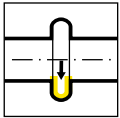

R = rechts wie gezeichnet
R = right hand version shown

L = links spiegelbildlich
L = left hand version

▲ ab Lager
on stock

HM-Sorten
Carbide grades
Δ 4 Wochen
4 weeks

Bestellnummer Part number	w	f	Ds	r	d	s	a	t _{max}	D _{min}	Z	HIS	MG12	EG55	TH35	TN35
R111.0004.08	0,8	6,7	13,4	0,4	8	3,95	10,7	2,3	11	1	308080R	▲	▲	▲	▲
R111.0006.12	1,2	6,7	13,4	0,6	8	3,95	10,7	2,3	11	1	308080R	▲	▲	▲	▲
R111.0009.18	1,8	6,7	13,4	0,9	8	3,95	10,7	2,3	11	1	308080R	▲	▲	▲	▲
R111.0010.20	2	6,7	13,4	1	8	3,95	10,7	2,3	11	1	308080R	▲	▲	▲	▲
R111.0015.30	3	6,7	13,4	1,5	8	3,95	10,7	2,3	11	1	308080R	▲	▲	▲	▲
L111.0004.08	0,8	6,7	13,4	0,4	8	3,95	10,7	2,3	11	1	308080L	▲	▲	▲	▲
L111.0006.12	1,2	6,7	13,4	0,6	8	3,95	10,7	2,3	11	1	308080L	Δ	▲	▲	▲
L111.0009.18	1,8	6,7	13,4	0,9	8	3,95	10,7	2,3	11	1	308080L	Δ	▲	▲	▲
L111.0010.20	2	6,7	13,4	1	8	3,95	10,7	2,3	11	1	308080L	▲	▲	▲	▲
L111.0015.30	3	6,7	13,4	1,5	8	3,95	10,7	2,3	11	1	308080L	Δ	▲	▲	▲
												P	o	•	•
												M	-	o	•
												K	-	o	•
												N	-	-	•
												S	-	-	•
												H	-	-	-

B

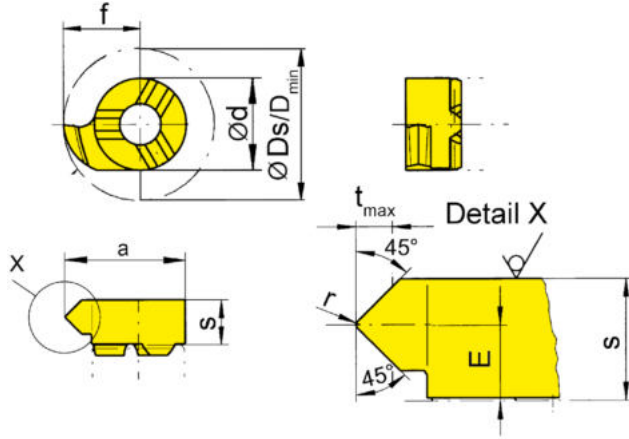
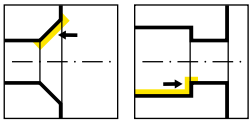

R = rechts wie gezeichnet
R = right hand version shown

L = links spiegelbildlich
L = left hand version

HM-Sorten
Carbide grades
▲ ab Lager
on stock
Δ 4 Wochen
4 weeks

Bestellnummer Part number	E	f	Ds	r	d	s	a	t _{max}	D _{min}	Z	HIS	EG55	TN35
R111.4545.02	2,4	6,7	13,4	0,2	8	4,15	10,7	1,5	11	1	308080R	▲	▲
L111.4545.02	2,4	6,7	13,4	0,2	8	4,15	10,7	1,5	11	1	308080L	▲	▲
P	●	●											
M	○	●											
K	○	●											
N	-	●											
S	-	●											
H	-	-											



Abbildung = rechtsschneidend
Picture = right hand cutting version

▲ ab Lager
on stock

HM-Sorten
Carbide grades
Δ 4 Wochen
4 weeks

Bestellnummer Part number	Ds	Nw	w	t ₁	s	s ₁	t _{max}	Z	HIS	AS45
308.1105.30	15,7	1,1	1,21	0,47	4,7	3,6	0,5	3	308080R	▲
308.1307.30	15,7	1,3	1,41	0,65	4,7	3,5	0,7	3	308080R	▲
										P ●
										M ●
										K ●
										N ○
										S ●
										H -

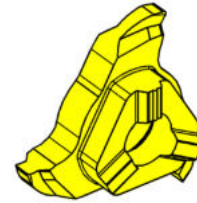
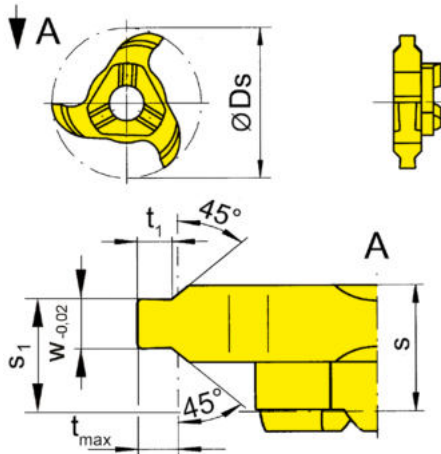
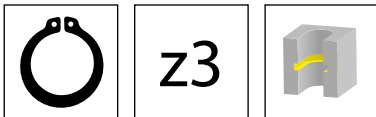
B



Abbildung = rechtsschneidend
Picture = right hand cutting version

▲ ab Lager
on stock

HM-Sorten
Carbide grades
Δ 4 Wochen
4 weeks

Bestellnummer Part number	Ds	Nw	w	s	t _{max}	Z	HIS	AS45	TF45	TN35
308.0110.00	15,7	1,1	1,21	4,5	3,5	3	308080R		▲	▲
308.0130.00	15,7	1,3	1,41	4,5	3,5	3	308080R	Δ	Δ	▲
308.0160.00	15,7	1,6	1,71	4,5	3,5	3	308080R	Δ	Δ	▲
								P	●	●
								M	●	●
								K	●	●
								N	○	●
								S	●	●
								H	-	-

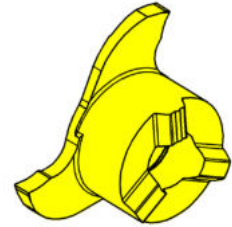
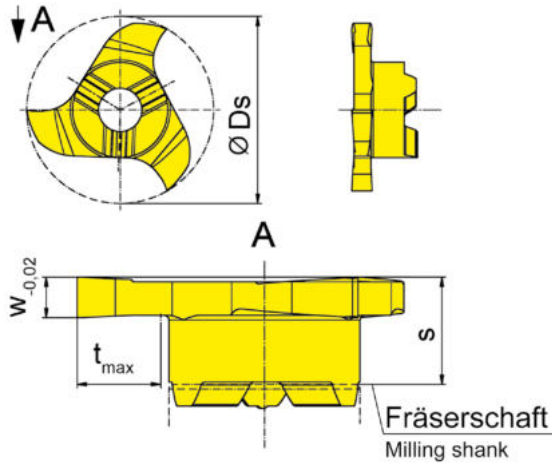
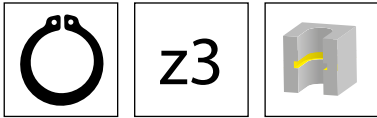

Abbildung = rechtsschneidend
Picture = right hand cutting version

▲ ab Lager on stock
 ▲ 4 Wochen 4 weeks
 HM-Sorten Carbide grades

Bestellnummer Part number	Ds	Nw	w	s	t _{max}	Z	HIS	Tl25
308.0110.40	15,7	1,1	1,21	4,5	3,5	3	308080R	▲
308.0130.40	15,7	1,3	1,41	4,5	3,5	3	308080R	▲
308.0160.40	15,7	1,6	1,71	4,5	3,5	3	308080R	▲
								P -
								M -
								K -
								N ●
								S -
								H -

B

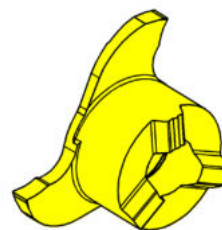
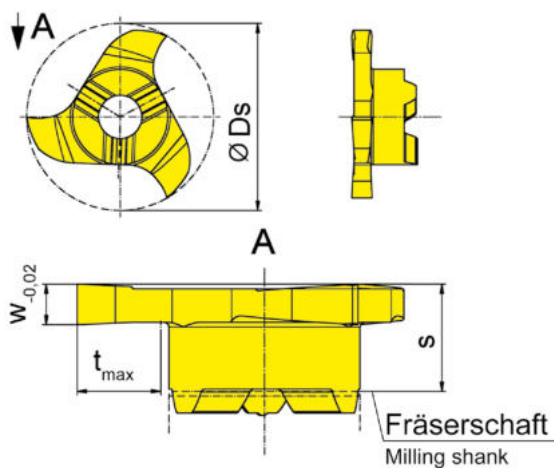
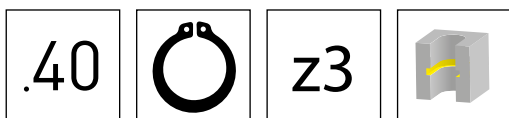
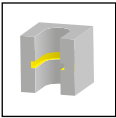

z3



Abbildung = rechtsschneidend
Picture = right hand cutting version

▲ ab Lager
on stock

HM-Sorten
Carbide grades

Δ 4 Wochen
4 weeks

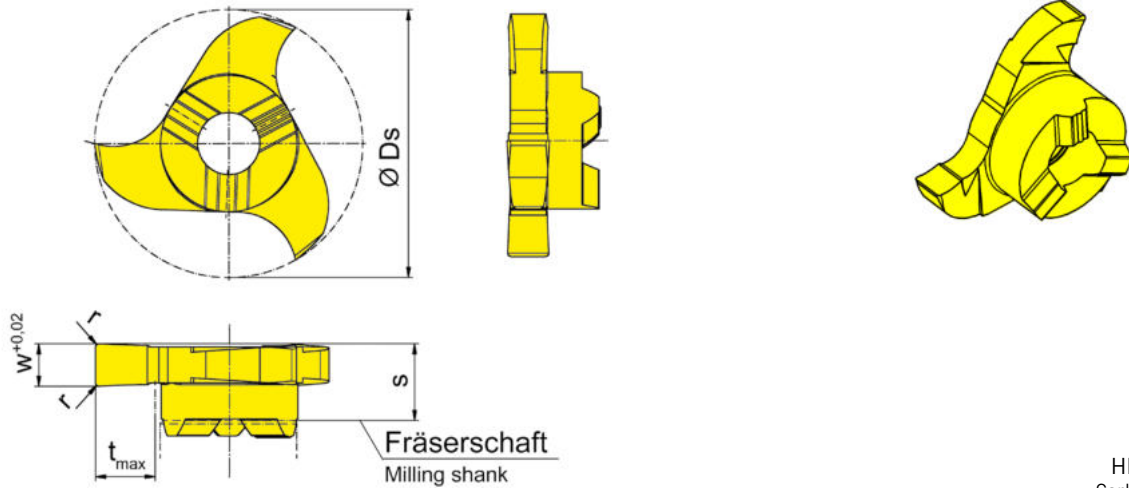
Bestellnummer Part number	Ds	w	s	r	t _{max}	Z	HIS	MG12	AS45	TF45	TN35
308.0150.00	15,7	1,5	4,5	-	3,5	3	308080R	▲	▲	▲	▲
308.0200.00	15,7	2	4,5	0,2	3,5	3	308080R	Δ	▲	Δ	▲
308.0250.00	15,7	2,5	4,5	0,2	3,5	3	308080R	▲	▲	▲	▲

Bei Reduzierung der Frästiefe t_{max} ist eine Schneidbreite w bis 0,5 mm auf Anfrage möglich.
Inserts for widths of groove t_{max} down to 0,5 mm can be delivered with reduced depth upon request.

P	o	•	•	•
M	-	•	•	•
K	-	•	•	•
N	-	o	•	•
S	-	•	•	•
H	-	-	-	-



Abbildung = rechtsschneidend
Picture = right hand cutting version

▲ ab Lager
on stock

HM-Sorten
Carbide grades

Δ 4 Wochen
4 weeks

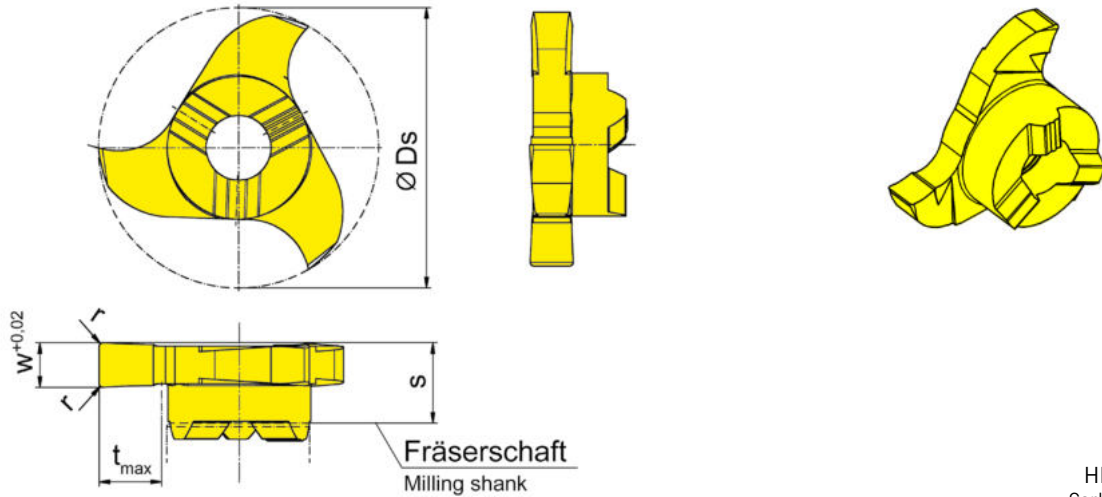
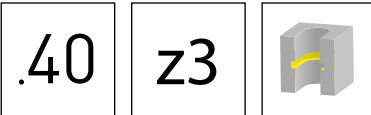
Bestellnummer Part number	Ds	w	s	r	t _{max}	Z	HIS	TI25
308.0150.40	15,7	1,5	4,5	-	3,5	3	308080R	▲
308.0200.40	15,7	2	4,5	0,2	3,5	3	308080R	▲
308.0250.40	15,7	2,5	4,5	0,2	3,5	3	308080R	▲

Bei Reduzierung der Frästiefe t_{max} ist eine Schneidbreite w bis 0,5 mm auf Anfrage möglich.
Inserts for widths of groove t_{max} down to 0,5 mm can be delivered with reduced depth upon request.

P	-
M	-
K	-
N	●
S	-
H	-

B



z3



Abbildung = rechtsschneidend
Picture = right hand cutting version

▲ ab Lager
on stock

HM-Sorten
Carbide grades

Δ 4 Wochen
4 weeks

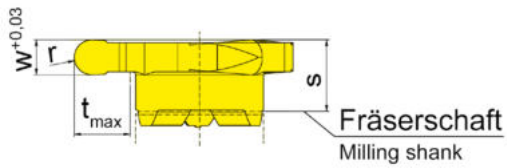
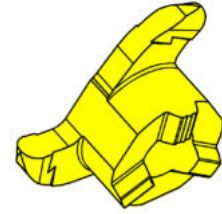
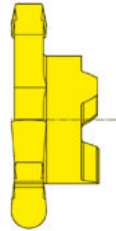
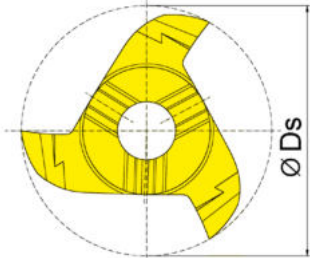
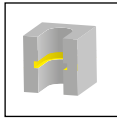
Bestellnummer Part number	Ds	w	s	r	t _{max}	Z	HIS	MG12	AN25	AS45	RC45	TF45	TI25	TN35
308.0005.10	15,7	1	4,5	0,5	3,5	3	308080R		▲		▲			
308.0007.15	15,7	1,5	4,5	0,75	3,5	3	308080R			▲				
308.0010.20	15,7	2	4,5	1	3,5	3	308080R			▲				
308.0011.22	15,7	2,2	4,5	1,1	3,5	3	308080R	Δ		▲		▲	Δ	▲
308.0015.30	15,7	3	4,5	1,5	3,5	3	308080R			▲				
308.0020.40	15,7	4	4,5	2	3,5	3	308080R			▲				
P	o	•	•	•	•	•								
M	-	o	•	•	•	•								
K	-	-	•	•	•	•								
N	-	-	o	-	•	•								
S	-	-	•	-	•	•								
H	-	-	-	-	-	-								



Abbildung = rechtsschneidend
Picture = right hand cutting version

▲ ab Lager
on stock

HM-Sorten
Carbide grades

Δ 4 Wochen
4 weeks

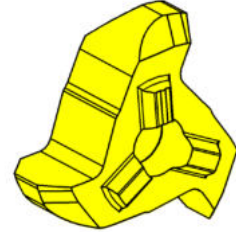
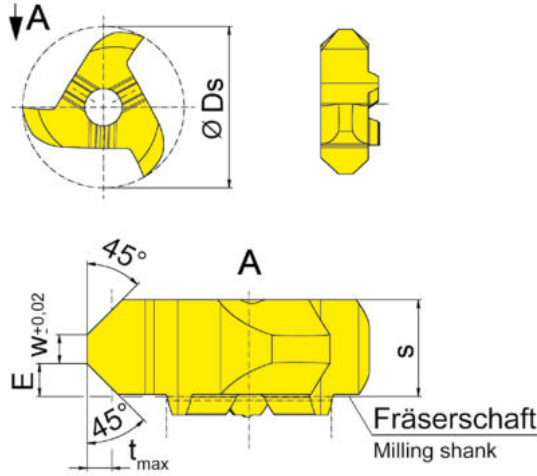
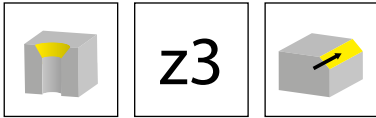
Bestellnummer Part number	Ds	E	s	w	t _{max}	Z	HIS	MG12	TF45	TI25	TN35
308.4545.00	15,7	1,6	4,7	1,4	1,2	3	308080R	Δ	Δ		▲
								P	o	•	•
								M	-	•	•
								K	-	•	•
								N	-	•	•
								S	-	•	•
								H	-	-	-

B

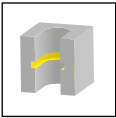

z6



Abbildung = rechtsschneidend
Picture = right hand cutting version

▲ ab Lager
on stock

HM-Sorten
Carbide grades
Δ 4 Wochen
4 weeks

Bestellnummer Part number	D_s	w	s	r	t_{max}	Z	HIS	AS45	EG35	IG35	TI25	
608.0025.00	15,7	0,25	4,9	-	3,5	6	308080R		▲	Δ		
608.0030.00	15,7	0,3	4,9	-	3,5	6	308080R		▲	Δ		
608.0040.00	15,7	0,4	4,9	-	3,5	6	308080R		▲	Δ		
608.0050.00	15,7	0,5	4,9	-	3,5	6	308080R		▲	Δ		
608.0060.00	15,7	0,6	4,9	-	3,5	6	308080R		▲	Δ		
608.0070.00	15,7	0,7	4,9	-	3,5	6	308080R		▲	Δ		
608.0080.00	15,7	0,8	4,9	-	3,5	6	308080R		▲	Δ		
608.0090.00	15,7	0,9	4,9	-	3,5	6	308080R		▲	Δ		
608.0100.00	15,7	1	4,9	-	3,5	6	308080R		▲	Δ		
608.0150.00	15,7	1,5	4,9	-	3,5	6	308080R	▲			▲	
608.0200.00	15,7	2	4,9	0,2	3,5	6	308080R	▲			▲	
608.0250.00	15,7	2,5	4,9	0,2	3,5	6	308080R	▲			▲	
								P	●	●	-	●
								M	●	●	●	●
								K	●	○	-	●
								N	○	-	-	●
								S	●	-	●	●
								H	-	-	-	-

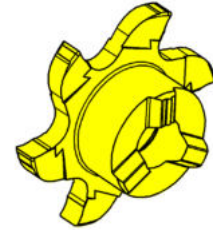
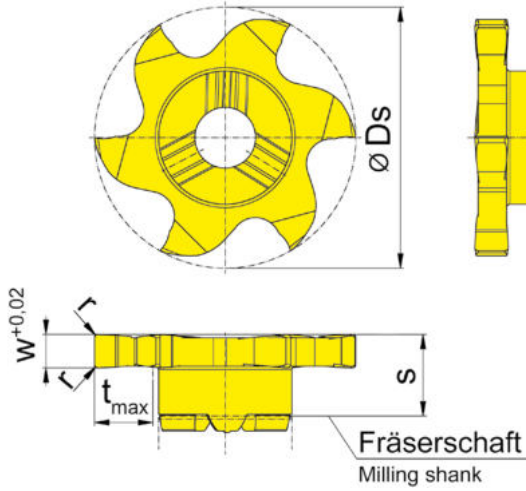
Bei Reduzierung der Frästiefe t_{max} ist eine Schneidbreite w bis 0,5 mm auf Anfrage möglich.
Inserts for widths of groove t_{max} down to 0,5 mm can be delivered with reduced depth upon request.



Abbildung = rechtsschneidend
Picture = right hand cutting version

▲ ab Lager
on stock

HM-Sorten
Carbide grades
Δ 4 Wochen
4 weeks

Bestellnummer Part number	Ds	E	s	w	α	b	t_{max}	Z	HIS	TA45	TI25
608.1515.20	15,7	2,6	5,1	0,2	15°	2,2	0,6	6	308080R	▲	
608.2020.20	15,7	2,6	5,1	0,2	20°	2,2	0,8	6	308080R	▲	
608.3030.20	15,7	2,6	5,1	0,2	30°	2,2	1,3	6	308080R	▲	
608.4545.20	15,7	2,6	5,1	0,2	45°	1,7	1,7	6	308080R		▲
										P	● ●
										M	● ●
										K	● ●
										N	● ●
										S	● ●
										H	- -

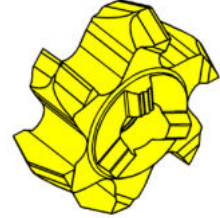
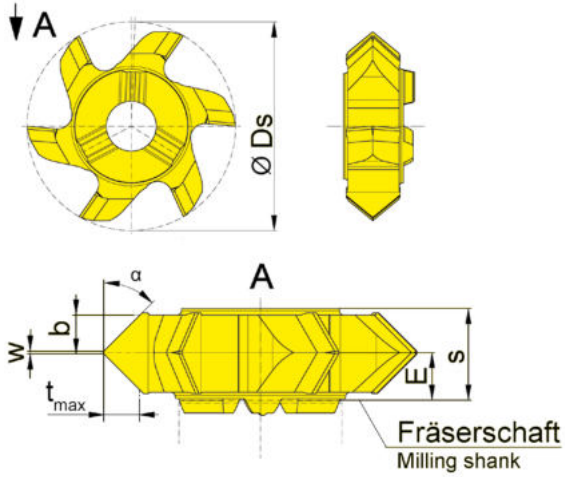
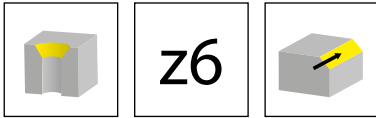
Nutfräsen (zirkular)

Groove Milling by circular interpolation



B

Frälerschaft
Milling shank
M311/M311.ST/M311.ER

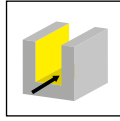

Seite/Page
90-94

Grundaufnahme
Basic Holder
WFB

Seite/Page
95

Einschraubfräser
Screw-in cutter
M311.M

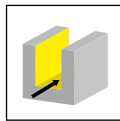

Seite/Page
96

Schneidplatte
Insert
311/611/911

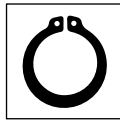

Seite/Page
97-98, 104



Seite/Page
99, 101

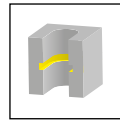

Seite/Page
100, 105, 108



Seite/Page
102

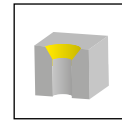

Seite/Page
103, 107

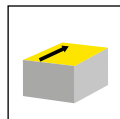

Seite/Page
106

M311



**Fräser mit wechselbarer
Schneidplatte**

ab Bohrung \varnothing 18 mm

**Milling shank with
exchangeable insert**

from bore \varnothing 18 mm

Fräuserschaft

Milling shank

M311



B

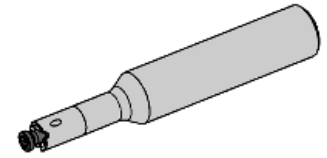
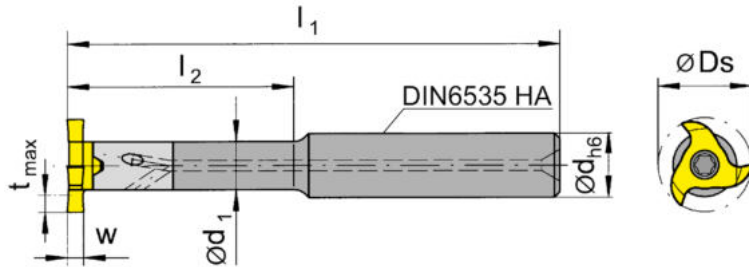
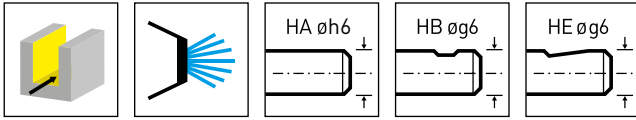

Bestellnummer Part number	d	l ₁	l ₂	d ₁	Form	HWS
M311.0012.01A	12	100	32	9	A	311090R
M311.0012.02A	12	100	45	9	A	311090R
M311.0012.03A	12	120	64	9	A	311090R
M311.0016.01A	16	100	32	9	A	311090R
M311.0016.02A	16	110	45	9	A	311090R
M311.0016.03A	16	130	64	9	A	311090R
M311.0012.01B	12	100	32	9	B	311090R
M311.0012.02B	12	100	45	9	B	311090R
M311.0012.03B	12	120	64	9	B	311090R
M311.0016.01B	16	100	32	9	B	311090R
M311.0016.02B	16	110	45	9	B	311090R
M311.0016.03B	16	130	64	9	B	311090R
M311.0012.01E	12	100	32	9	E	311090R
M311.0012.02E	12	100	45	9	E	311090R
M311.0012.03E	12	120	64	9	E	311090R
M311.0016.01E	16	100	32	9	E	311090R
M311.0016.02E	16	110	45	9	E	311090R
M311.0016.03E	16	130	64	9	E	311090R

w, Ds, tmax siehe Schneidplatte
w, Ds, tmax see inserts

Ersatzteile

Spare Parts

Fräuserschaft Milling shank	Spannschraube Clamping Screw	TORX PLUS®-Schlüssel TORX PLUS® Wrench
M311...	4.14T15P	T15PQ

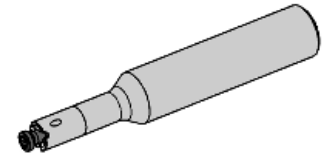
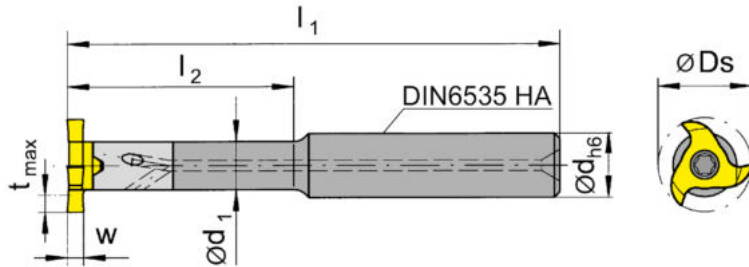
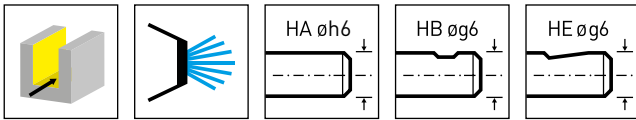

Bestellnummer Part number	d	l ₁	l ₂	d ₁	Form	HWS
M311.1316.01A	16	110	32	13	A	311090R
M311.1316.02A	16	130	45	13	A	311090R
M311.1316.03A	16	145	64	13	A	311090R
M311.1316.01B	16	110	32	13	B	311090R
M311.1316.02B	16	130	45	13	B	311090R
M311.1316.03B	16	145	64	13	B	311090R
M311.1316.01E	16	110	32	13	E	311090R
M311.1316.02E	16	130	45	13	E	311090R
M311.1316.03E	16	145	64	13	E	311090R

w, Ds, tmax siehe Schneidplatte
w, Ds, tmax see inserts

Ersatzteile
Spare Parts

Fräuserschaft Milling shank	Spannschraube Clamping Screw	TORX PLUS®-Schlüssel TORX PLUS® Wrench
M311...	4.14T15P	T15PQ

B

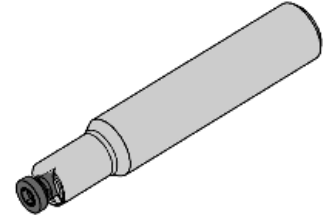
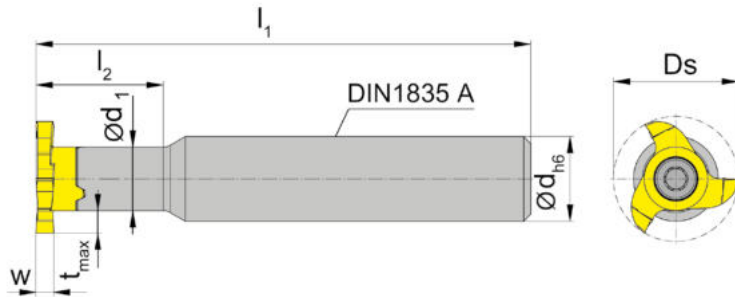
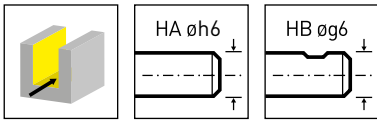

Bestellnummer Part number	d	l_1	l_2	d_1	Form	HWS
M311.ST10.01A	10	60	18	9	A	311090R
M311.ST12.01A	12	70	18	9	A	311090R
M311.ST13.01A	13	70	26	9	A	311090R
M311.ST16.01A	16	80	26	9	A	311090R
M311.ST10.01B	10	60	18	9	B	311090R
M311.ST12.01B	12	70	18	9	B	311090R
M311.ST16.01B	16	80	26	9	B	311090R

w, D_s , t_{max} siehe Schneidplatte
w, D_s , t_{max} see inserts

Ersatzteile

Spare Parts

Fräaserschaft Milling shank	Spannschraube Clamping Screw	TORX PLUS®-Schlüssel TORX PLUS® Wrench
M311...	4.14T15P	T15PQ

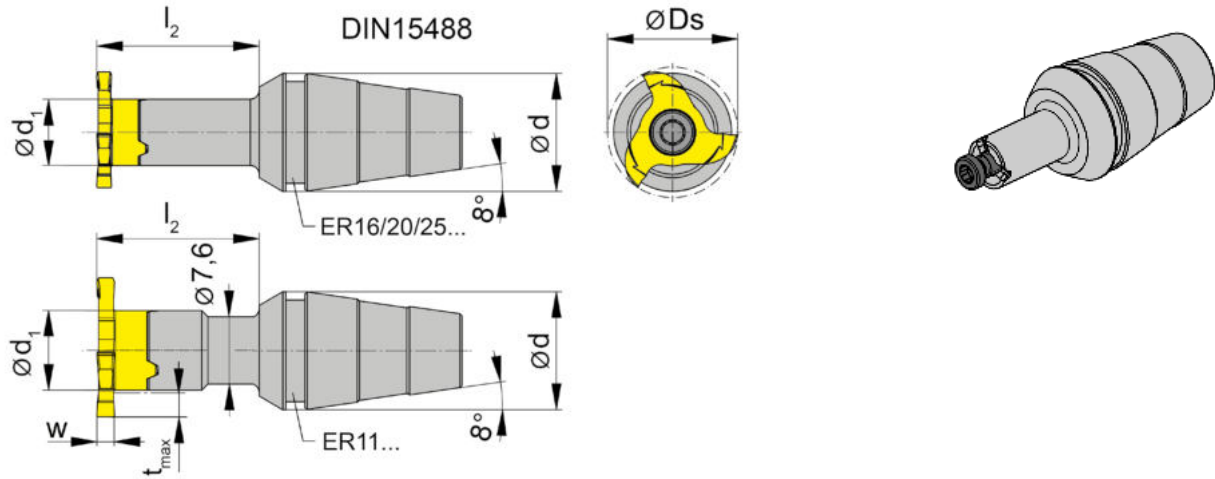
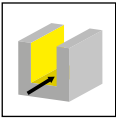

Bestellnummer Part number	d	l ₂	d ₁	Spannmutter Clamping nut	HWS
M311.ER11.02	11	22	9	ER11.6499	311090R
M311.ER25.02	25	22	9	ER25.6499	311090R
M311.ER16.02	16	22	9	ER16.6499/ERM16.6499	311090R
M311.ER20.02	20	22	9	ER20.6499/ERM20.6499	311090R
M311.ER20.14.01	20	19,7	12,5	ER20.6499/ERM20.6499	311090R
M311.ER25.14.01	25	19,7	14,5	ER25.6499	311090R

w, Ds, tmax siehe Schneidplatte
w, Ds, tmax see inserts

Ersatzteile
Spare Parts

Frälerschaft Milling shank	Spannschraube Clamping Screw	TORX PLUS®-Schlüssel TORX PLUS® Wrench
M311.E...	4.14T15P	T15PQ
M311.ER25.14.01	4.14T15P	T15PL

B

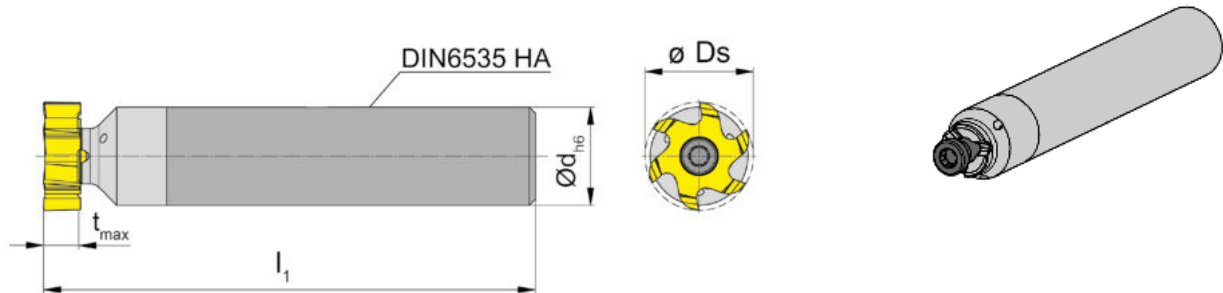
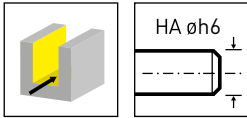

Bestellnummer Part number	d	l ₁	Form	HWS
M311.0012.D.00A	12	80	A	311090R
M311.0016.D.00A	16	80	A	311090R

t_{max} und D_s siehe SP
t_{max} and D_s see inserts

Ersatzteile

Spare Parts

Fräserschaft Milling shank	Spannschraube Clamping Screw	TORX PLUS®-Schlüssel TORX PLUS® Wrench
M311...	4.14T15P	T15PQ

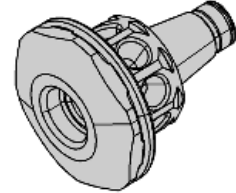
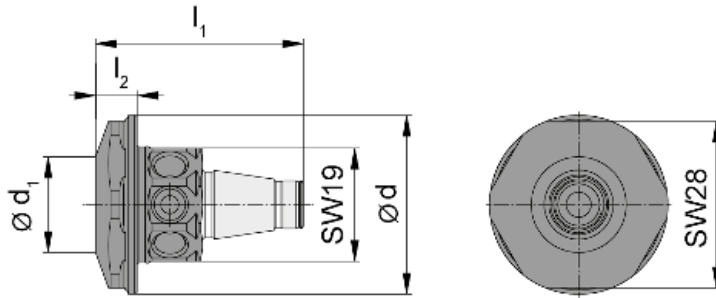

Bestellnummer Part number	l_1	l_2	d_1	d
WFB.2012.M081.01	35	7	16	30

für Einschraubfräser
for Screw-in cutter

B

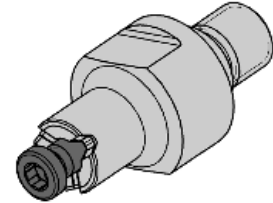
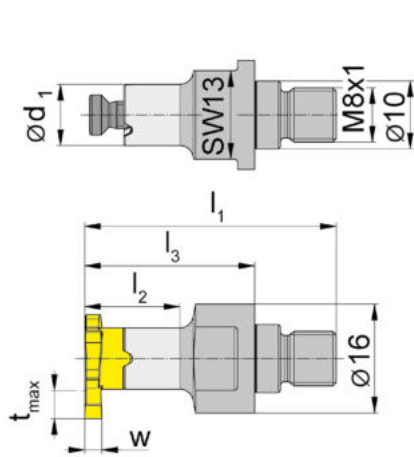
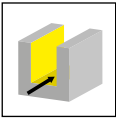

Bestellnummer Part number	l_1	l_2	l_3	d_1	SW	HWS	HMS
M311.M081.01	37	14	25	9	13	311090R	8201

w, D_s , t_{max} siehe Schneidplatte
w, D_s , t_{max} see inserts

Ersatzteile

Spare Parts

Einschraubfräser Screw-in cutter	Spannschraube Clamping Screw	TORX PLUS®-Schlüssel TORX PLUS® Wrench
M311.M081.01	4.14T15P	T15PQ



Abbildung = rechtsschneidend
Picture = right hand cutting version

▲ ab Lager
on stock

HM-Sorten
Carbide grades
Δ 4 Wochen
4 weeks

Bestellnummer Part number	Ds	Nw	w	s	t _{max}	Z	HIS	HM-Sorten Carbide grades	
								AS45	TN35
311.0110.00	17,7	1,1	1,21	5,75	3,5	3	311090R	▲	▲
311.0130.00	17,7	1,3	1,41	5,75	3,5	3	311090R	Δ	▲
311.0160.00	17,7	1,6	1,71	5,75	3,5	3	311090R	Δ	▲
								P	● ●
								M	● ●
								K	● ●
								N	○ ●
								S	● ●
								H	- -

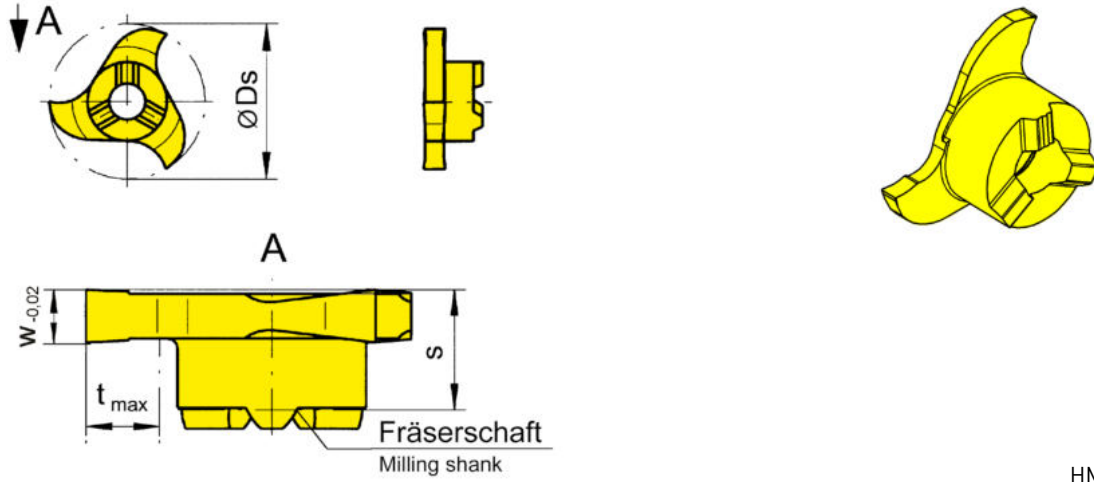
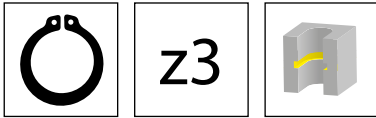
B



Abbildung = rechtsschneidend
Picture = right hand cutting version

HM-Sorten
Carbide grades
▲ ab Lager
on stock
Δ 4 Wochen
4 weeks

Bestellnummer Part number	Ds	Nw	w	t ₁	s	s ₁	r	t _{max}	Z	HIS	AS45
311.1307.30	17,7	1,3	1,41	0,65	5,95	4,7	-	0,7	3	311090R	▲
311.1812.35	17,7	1,85	1,96	1,21	5,95	5	0,2	1,25	3	311090R	▲
											P ●
											M ●
											K ●
											N ○
											S ●
											H -

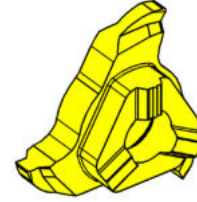
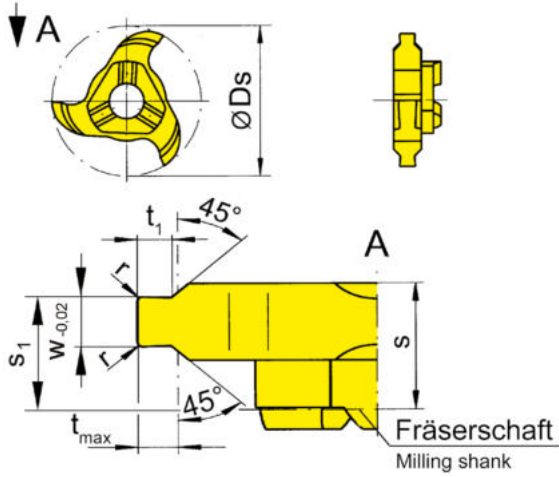
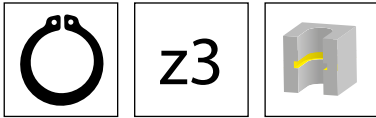

Abbildung = rechtsschneidend
Picture = right hand cutting version

HM-Sorten
Carbide grades
▲ ab Lager
on stock
Δ 4 Wochen
4 weeks

Bestellnummer Part number	Ds	Nw	w	s	t _{max}	Z	HIS	T125
311.0110.40	17,7	1,1	1,21	5,75	3,5	3	311090R	▲
311.0130.40	17,7	1,3	1,41	5,75	3,5	3	311090R	▲
311.0160.40	17,7	1,6	1,71	5,75	3,5	3	311090R	Δ
								P -
								M -
								K -
								N ●
								S -
								H -

B

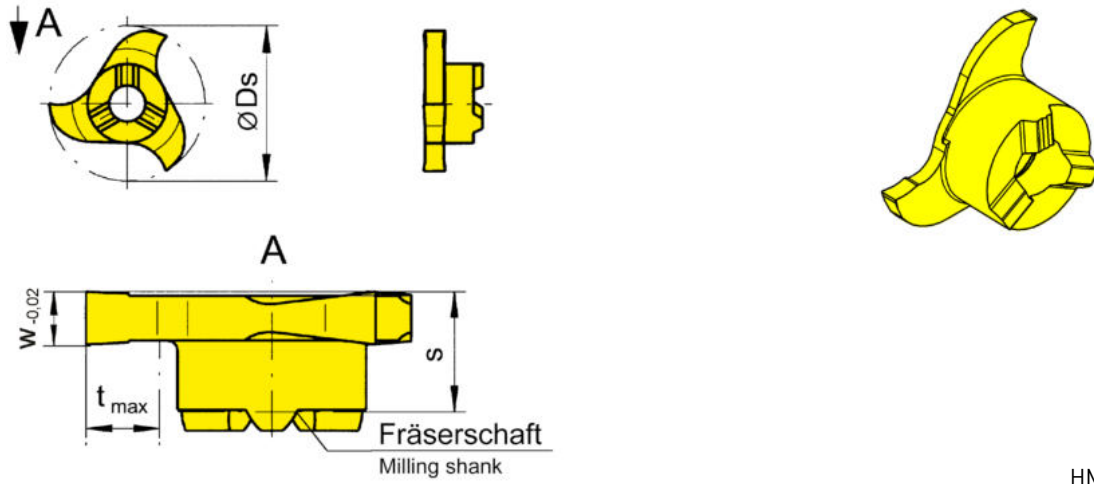
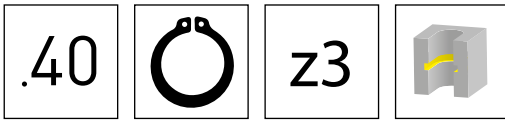
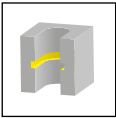

z3



Abbildung = rechtsschneidend
Picture = right hand cutting version

▲ ab Lager
on stock

HM-Sorten
Carbide grades
Δ 4 Wochen
4 weeks

Bestellnummer Part number	Ds	w	s	r	t _{max}	Z	HIS	HM-Sorten Carbide grades		
								MG12	AS45	TN35
311.0150.00	17,7	1,5	5,75	-	3,5	3	311090R		▲	▲
311.0200.00	17,7	2	5,75	0,2	3,5	3	311090R	Δ	▲	▲
311.0250.00	17,7	2,5	5,75	0,2	3,5	3	311090R		▲	▲
311.0300.00	17,7	3	5,75	0,2	3,5	3	311090R	▲	▲	▲
311.0400.00	17,7	4	5,75	0,2	3,5	3	311090R		▲	
								P	o	•
								M	-	•
								K	-	•
								N	-	o
								S	-	•
								H	-	-

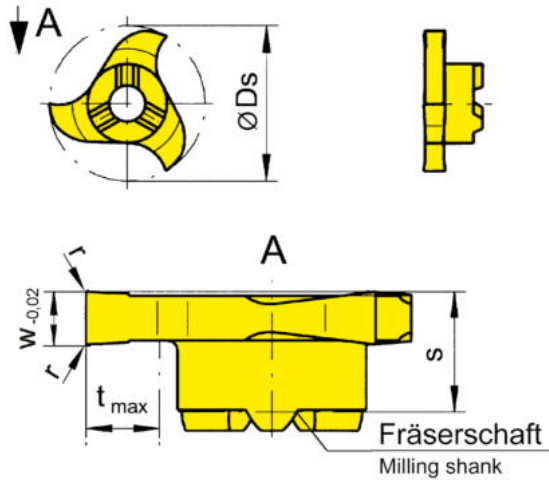

Abbildung = rechtsschneidend
Picture = right hand cutting version

▲ ab Lager
on stock

HM-Sorten
Carbide grades

Δ 4 Wochen
4 weeks

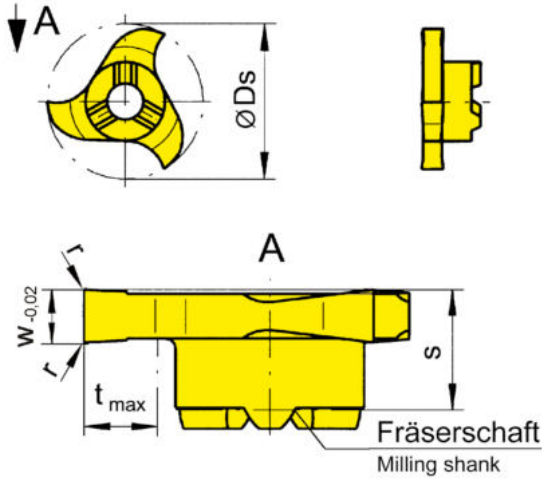
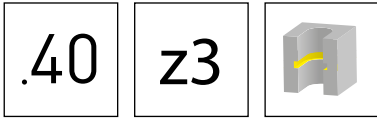
Bestellnummer Part number	Ds	w	s	r	t _{max}	Z	HIS	Ti25
311.0150.40	17,7	1,5	5,75	-	3,5	3	311090R	▲
311.0200.40	17,7	2	5,75	0,2	3,5	3	311090R	▲
311.0250.40	17,7	2,5	5,75	0,2	3,5	3	311090R	▲
311.0300.40	17,7	3	5,75	0,2	3,5	3	311090R	▲
311.0400.40	17,7	4	5,75	0,2	3,5	3	311090R	▲
								P -
								M -
								K -
								N ●
								S -
								H -

B



Abbildung = rechtsschneidend
Picture = right hand cutting version

▲ ab Lager
on stock

△ 4 Wochen
4 weeks

HM-Sorten
Carbide grades

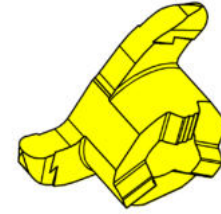
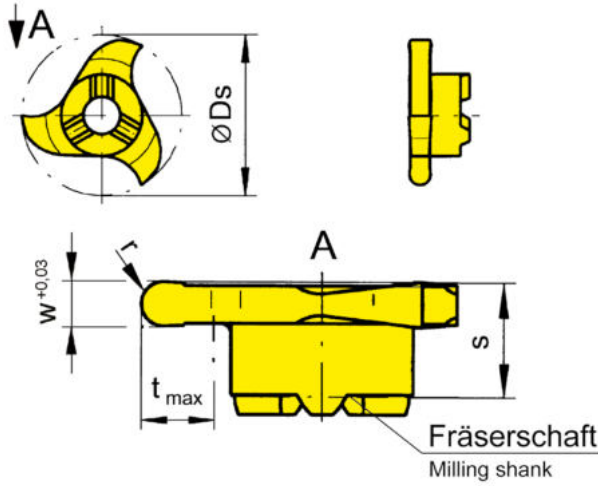
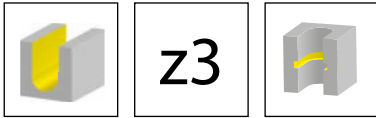
Bestellnummer Part number	Ds	w	s	r	t _{max}	Z	HIS		AN25	AS45	RC45	TN35
311.0005.10	17,7	1	5,75	0,5	3,5	3	311090R	▲				
311.0007.15	17,7	1,5	5,75	0,75	3,5	3	311090R		▲			
311.0010.20	17,7	2	5,75	1	3,5	3	311090R		▲			
311.0011.22	17,7	2,2	5,75	1,1	3,5	3	311090R		▲			▲
311.0015.30	17,7	3	5,75	1,5	3,5	3	311090R		▲			
311.0020.40	17,7	4	5,75	2	3,5	3	311090R		▲			
								P	●	●	●	●
								M	○	●	●	●
								K	-	●	●	●
								N	-	○	-	●
								S	-	●	-	●
								H	-	-	-	-



Abbildung = rechtsschneidend
Picture = right hand cutting version

▲ ab Lager
on stock

HM-Sorten
Carbide grades

Δ 4 Wochen
4 weeks

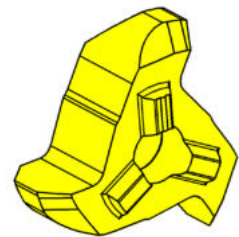
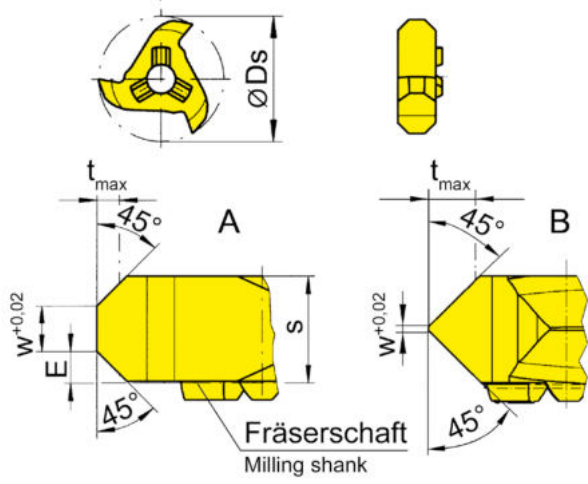
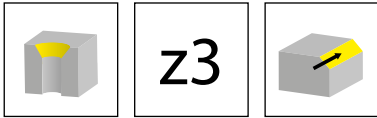
Bestellnummer Part number	Ds	E	s	w	Form	t _{max}	Z	HIS		TI25	TN35
311.4545.00	17,7	1,7	5,95	2,5	A	1,4	3	311090R			▲
311.4545.20	15	2,95	5,95	0,2	B	2,5	3	311090R		▲	▲
									P	●	●
									M	●	●
									K	●	●
									N	●	●
									S	●	●
									H	-	-

B



Abbildung = rechtsschneidend
Picture = right hand cutting version

▲ ab Lager
on stock

HM-Sorten
Carbide grades
Δ 4 Wochen
4 weeks

Bestellnummer Part number	Ds	Nw	w	s	t _{max}	Z	HIS	AS45	TI25
611.0110.00	17,7	1,1	1,21	6,1	3,5	6	311090L	▲	▲
611.0130.00	17,7	1,3	1,41	6,1	3,5	6	311090L	▲	▲
611.0160.00	17,7	1,6	1,71	6,1	3,5	6	311090L	▲	▲
								P ● ●	
								M ● ●	
								K ● ●	
								N ○ ●	
								S ● ●	
								H - -	

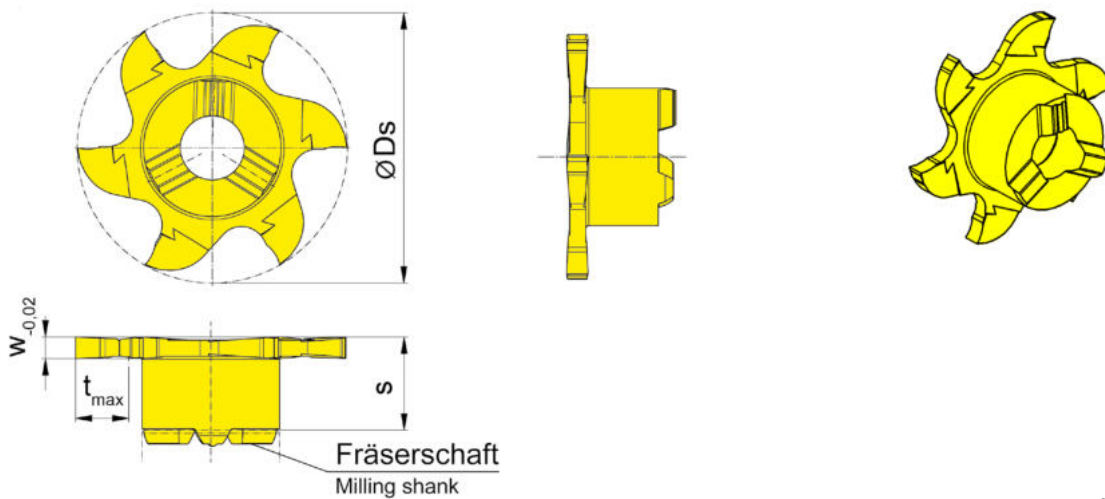
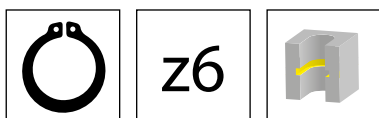
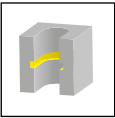

z6

B



Abbildung = rechtsschneidend
Picture = right hand cutting version

▲ ab Lager
on stock

HM-Sorten
Carbide grades

Δ 4 Wochen
4 weeks

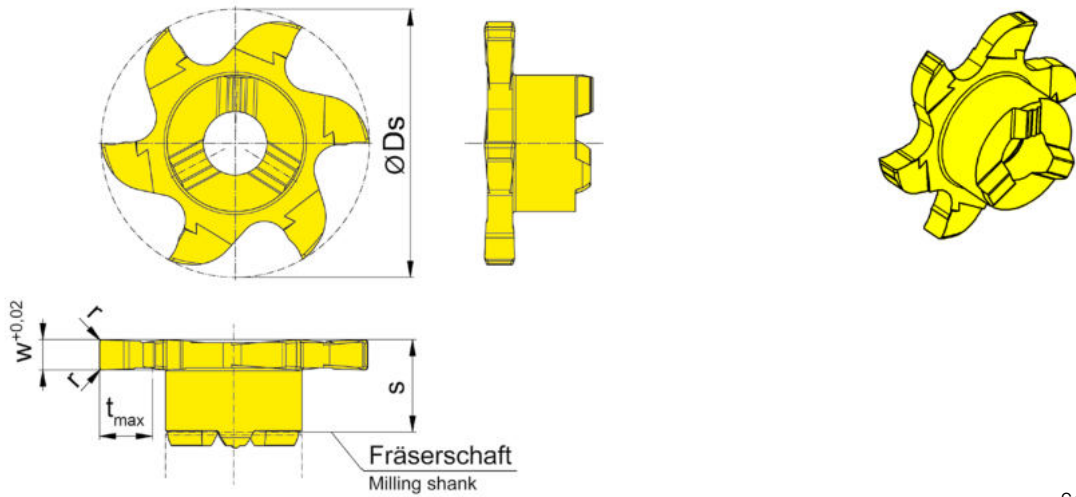
Bestellnummer Part number	Ds	w	s	r	t _{max}	Z	HIS	AS45	TI25
611.0150.00	17,7	1,5	6,1	-	3,5	6	311090L	▲	▲
611.0200.00	17,7	2	6,1	0,2	3,5	6	311090L	▲	▲
611.0250.00	17,7	2,5	6,1	0,2	3,5	6	311090L	▲	▲
611.0300.00	17,7	3	6,1	0,2	3,5	6	311090L	▲	▲
611.0400.00	17,7	4	6,1	0,2	3,5	6	311090L	▲	▲

ab Schneidbreite 2,5 mm Kreuzverzahnung
from width of groove 2,5 mm toothing with cross-cut

P	●	●
M	●	●
K	●	●
N	○	●
S	●	●
H	-	-

B



Abbildung = rechtsschneidend
Picture = right hand cutting version

▲ ab Lager
on stock

HM-Sorten
Carbide grades

Δ 4 Wochen
4 weeks

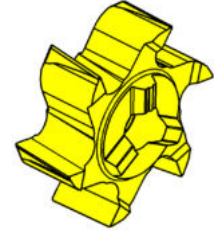
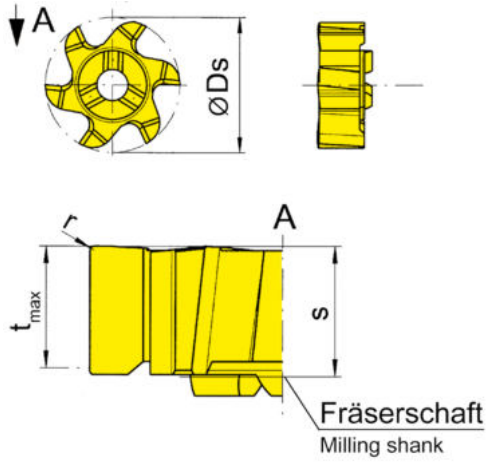
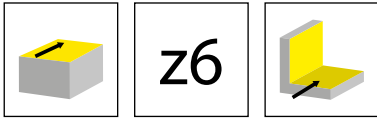
Bestellnummer Part number	Ds	Z	r	t _{max}	s	HIS	AS45	TF45	TI25
611.PL61.62	17,7	6	0,2	5,7	6,1	311090L	▲	▲	▲
							P ●	●	●
							M ●	●	●
							K ●	●	●
							N ○	●	●
							S ●	●	●
							H -	-	-



Abbildung = rechtsschneidend
Picture = right hand cutting version

▲ ab Lager
on stock

HM-Sorten
Carbide grades
Δ 4 Wochen
4 weeks

Bestellnummer Part number	Ds	E	s	w	α	b	t _{max}	Z	HIS	AS45	TA45	TI25
611.1515.20	17,7	3,2	6,3	0,2	15°	2,8	0,75	6	311090L	▲	▲	
611.2020.20	17,7	3,2	6,3	0,2	20°	2,8	1	6	311090L	▲	▲	
611.3030.20	17,7	3,2	6,3	0,2	30°	2,8	1,6	6	311090L	▲	▲	
611.4545.20	17,7	3,2	6,3	0,2	45°	2,3	2,3	6	311090L	▲		▲
P	●	●	●									
M	●	●	●									
K	●	●	●									
N	○	●	●									
S	●	●	●									
H	-	-	-									

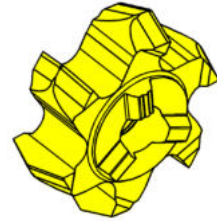
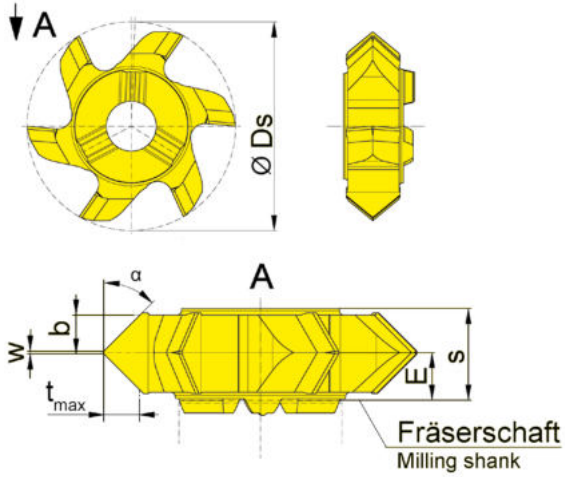
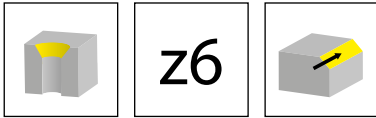
B

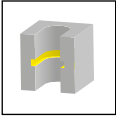

z9



Abbildung = rechtsschneidend
Picture = right hand cutting version

▲ ab Lager
on stock

HM-Sorten
Carbide grades
Δ 4 Wochen
4 weeks

Bestellnummer Part number	Ds	w	s	b x 45°	r	t _{max}	Z	HIS	EG55	IG65
911.0150.00	17,7	1,5	6,1	0,05	-	3,5	9	311090R	▲	Δ
911.0200.00	17,7	2	6,1	-	0,2	3,5	9	311090R	▲	Δ
911.0250.00	17,7	2,5	6,1	-	0,2	3,5	9	311090R	▲	Δ
911.0300.00	17,7	3	6,1	-	0,2	3,5	9	311090R	▲	Δ
									P ● ●	
									M ○ ●	
									K ○ -	
									N - -	
									S - ○	
									H - -	

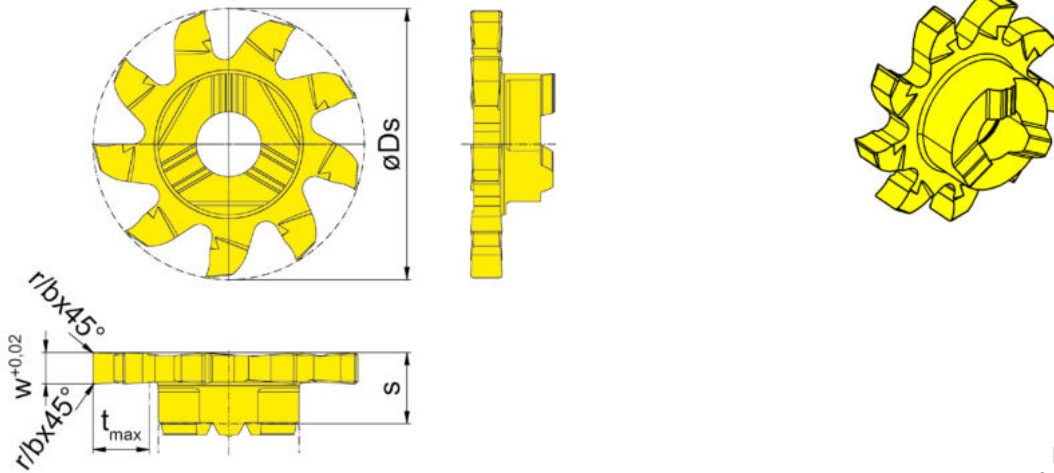
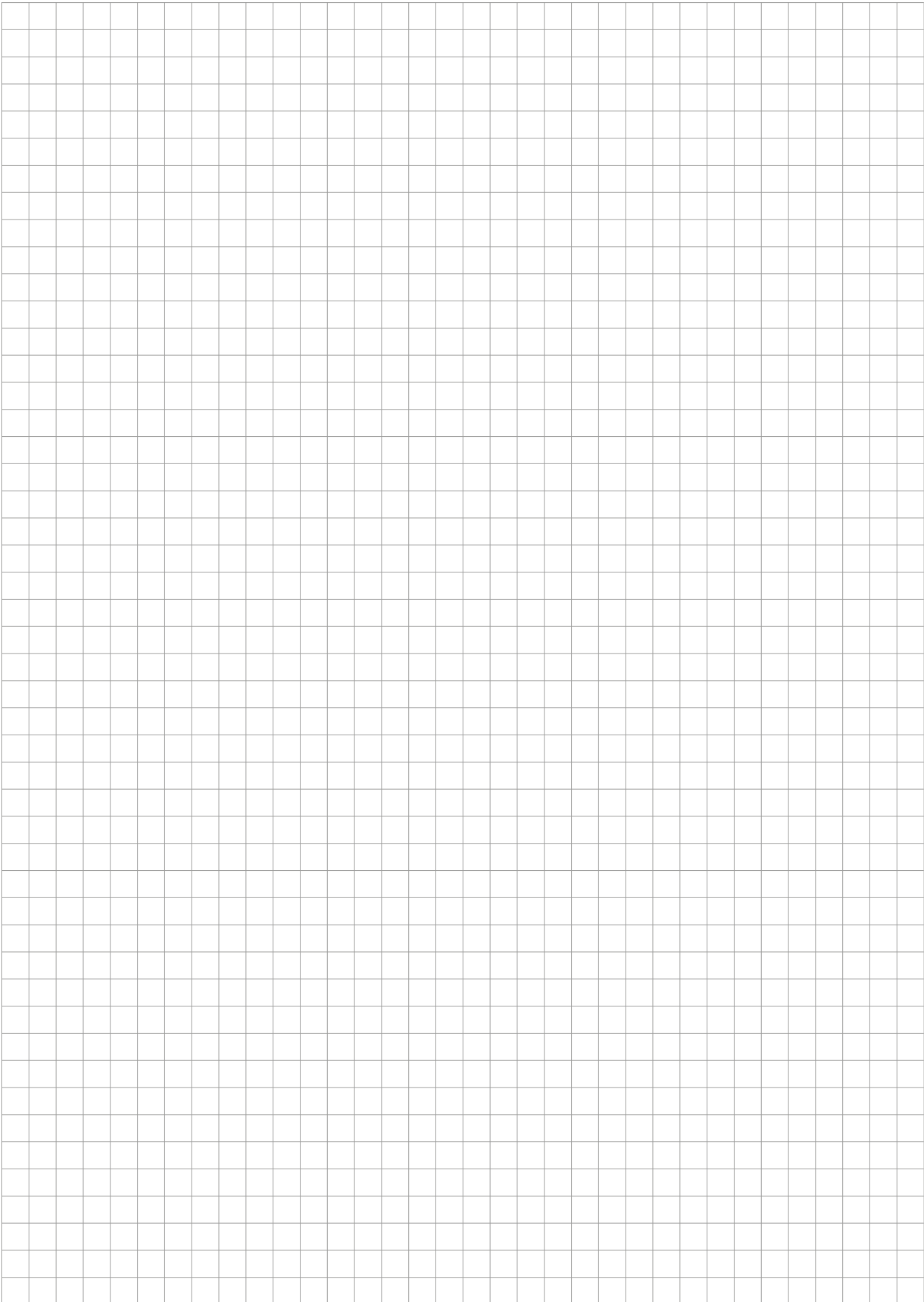

Nutfräsen (zirkular)

Groove Milling by circular interpolation

B

Frälerschaft
Milling shank
M116

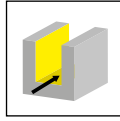

Seite/Page
112

Schneidplatte
Insert
116

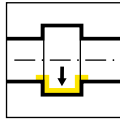

Seite/Page
113-114

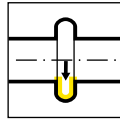

Seite/Page
115

M116



Fräser mit wechselbarer Schneidplatte

ab Bohrung
stehend \varnothing 16 mm
rotierend \varnothing 20,4 mm

Milling shank with exchangeable insert

from bore
non rotating \varnothing 16 mm
rotating \varnothing 20,4 mm

B

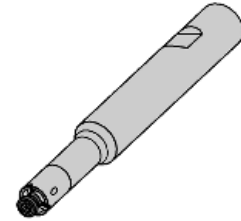
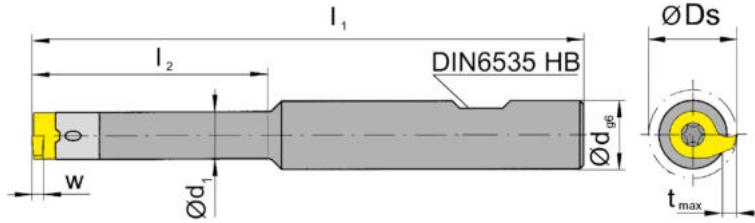
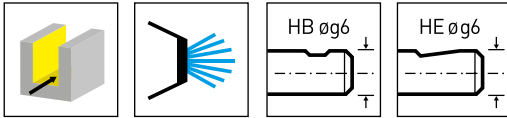

Bestellnummer Part number	d	l ₁	l ₂	d ₁	Form	HWS
M116.0012.01B	12	130	40	11	B	116110R • 116110L
M116.0012.02B	12	130	56	11	B	116110R • 116110L
M116.0016.01B	16	130	40	11	B	116110R • 116110L
M116.0016.02B	16	130	56	11	B	116110R • 116110L
M116.0016.03B	16	150	80	11	B	116110R • 116110L
M116.0016.01E	16	130	40	11	E	116110R • 116110L
M116.0016.03E	16	150	80	11	E	116110R • 116110L

w, D_s, t_{max} siehe Schneidplatte
w, D_s, t_{max} see inserts

Bearbeitungshinweis ab Ø 16 mm:

Nur Anspiegeln bei außermittigem Ein- und Ausfahren mit definiertem Spindelstop.

Note from Ø 16 mm:

Only back face milling with oriented spindlestop offset of centerline.

Ersatzteile

Spare Parts

Frälerschaft Milling shank	Spannschraube Clamping Screw	TORX PLUS®-Schlüssel TORX PLUS® Wrench
M116...	5.13T20EP	T20PQ

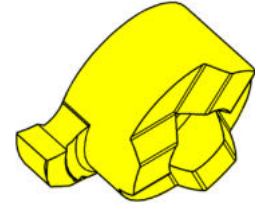
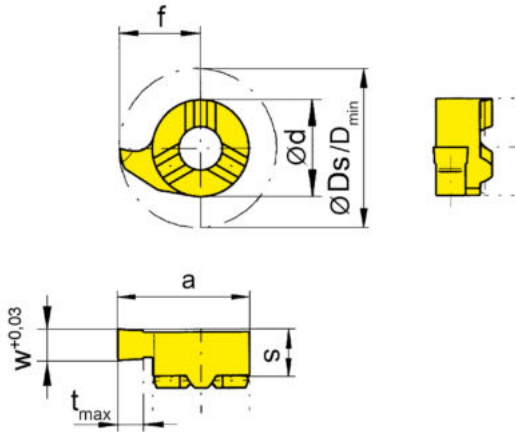
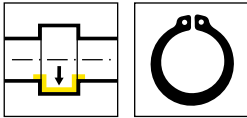

R = rechts wie gezeichnet
R = right hand version shown

L = links spiegelbildlich
L = left hand version

▲ ab Lager
on stock

HM-Sorten
Carbide grades
Δ 4 Wochen
4 weeks

Bestellnummer Part number	w	Nw	f	Ds	a	d	t _{max}	D _{min}	HIS	MG12	EG55	TH35	TN35
R116.0110.00	1,19	1,1	10,2	20,4	15,7	11	4,3	16	116110R	▲	▲	▲	▲
R116.0130.00	1,39	1,3	10,2	20,4	15,7	11	4,3	16	116110R	▲	▲	▲	▲
R116.0160.00	1,69	1,6	10,2	20,4	15,7	11	4,3	16	116110R	▲	▲	▲	▲
L116.0110.00	1,19	1,1	10,2	20,4	15,7	11	4,3	16	116110L	▲	▲	▲	▲
L116.0130.00	1,39	1,3	10,2	20,4	15,7	11	4,3	16	116110L	▲	▲	▲	▲
L116.0160.00	1,69	1,6	10,2	20,4	15,7	11	4,3	16	116110L	▲	▲	▲	▲
										P	o	•	•
										M	-	o	•
										K	-	o	•
										N	-	-	•
										S	-	-	•
										H	-	-	-

B

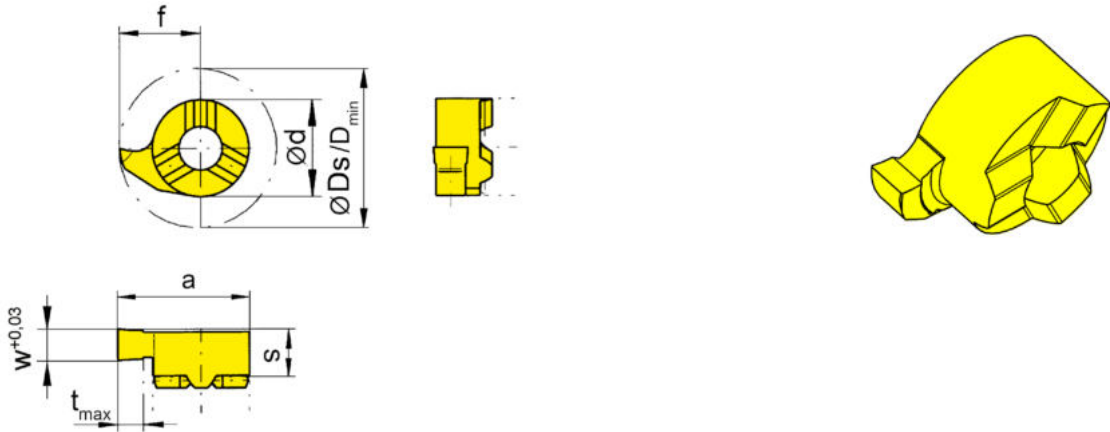
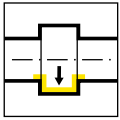

R = rechts wie gezeichnet
R = right hand version shown

L = links spiegelbildlich
L = left hand version

▲ ab Lager
on stock

HM-Sorten
Carbide grades
▲ 4 Wochen
4 weeks

Bestellnummer Part number	w	f	Ds	a	d	t _{max}	D _{min}	HIS	MG12	EG55	TH35	TN35
R116.0200.00	2	10,2	20,4	15,7	11	4,3	16	116110R	▲	▲	▲	▲
R116.0250.00	2,5	10,2	20,4	15,7	11	4,3	16	116110R	▲	▲	▲	▲
R116.0300.00	3	10,2	20,4	15,7	11	4,3	16	116110R	▲	▲	▲	▲
R116.0350.00	3,5	10,2	20,4	15,7	11	4,3	16	116110R	▲	▲	▲	▲
R116.0400.00	4	10,2	20,4	15,7	11	4,3	16	116110R	▲	▲	▲	▲
L116.0200.00	2	10,2	20,4	15,7	11	4,3	16	116110L	▲	▲	▲	▲
L116.0250.00	2,5	10,2	20,4	15,7	11	4,3	16	116110L	▲	▲	▲	▲
L116.0300.00	3	10,2	20,4	15,7	11	4,3	16	116110L	▲	▲	▲	▲
L116.0350.00	3,5	10,2	20,4	15,7	11	4,3	16	116110L	▲	▲	▲	▲
L116.0400.00	4	10,2	20,4	15,7	11	4,3	16	116110L	▲	▲	▲	▲
P	o	•	•	•								
M	-	o	•	•								
K	-	o	•	•								
N	-	-	•	•								
S	-	-	•	•								
H	-	-	-	-								

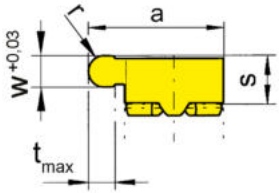
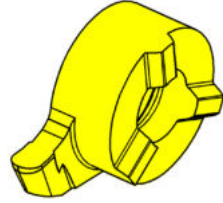
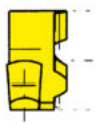
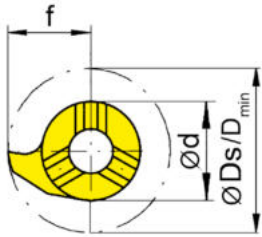
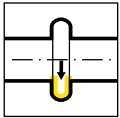

R = rechts wie gezeichnet
R = right hand version shown

L = links spiegelbildlich
L = left hand version

▲ ab Lager
on stock

△ 4 Wochen
4 weeks

HM-Sorten
Carbide grades

Bestellnummer Part number	w	f	Ds	a	r	d	t _{max}	D _{min}	HIS	MG12	EG55	TH35	TN35
R116.0009.18	1,8	10,2	20,4	15,7	0,9	11	4,3	16	116110R	▲	▲	▲	▲
R116.0011.22	2,2	10,2	20,4	15,7	1,1	11	4,3	16	116110R	▲	▲	▲	▲
R116.0015.30	3	10,2	20,4	15,7	1,5	11	4,3	16	116110R	▲	▲	▲	▲
R116.0020.40	4	10,2	20,4	15,7	2	11	4,3	16	116110R	△	▲	▲	▲
L116.0009.18	1,8	10,2	20,4	15,7	0,9	11	4,3	16	116110L	△	▲	▲	▲
L116.0011.22	2,2	10,2	20,4	15,7	1,1	11	4,3	16	116110L	△	▲	▲	▲
L116.0015.30	3	10,2	20,4	15,7	1,5	11	4,3	16	116110L	△	▲	▲	▲
L116.0020.40	4	10,2	20,4	15,7	2	11	4,3	16	116110L	△	▲	▲	▲
										P	o	•	•
										M	-	o	•
										K	-	o	•
										N	-	-	•
										S	-	-	•
										H	-	-	-

Nutfräsen (zirkular)

Groove Milling by circular interpolation

B

Frälerschaft
Milling shank
M313/M313.ST/M313.ER

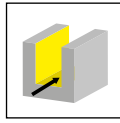

Seite/Page
118-123

Grundaufnahme
Basic Holder
WFB

Seite/Page
124

Einschraubfräser
Screw-in cutter
M313.M

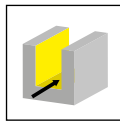

Seite/Page
125

Schneidplatte
Insert
313/L313/613/713
913

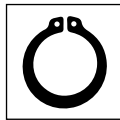

Seite/Page
126-127, 129-
130, 138-139



Seite/Page
128, 1132

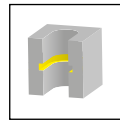

Seite/Page
131, 133-134,
137, 140, 147,
149



Seite/Page
135

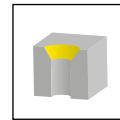

Seite/Page
136, 145-146

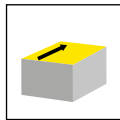

Seite/Page
141-143, 148

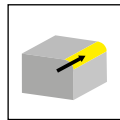

Seite/Page
144

M313



**Fräser mit wechselbarer
Schneidplatte**

ab Bohrung \emptyset 22 mm

**Milling shank with
exchangeable insert**

from bore \emptyset 22 mm

B

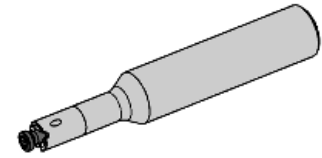
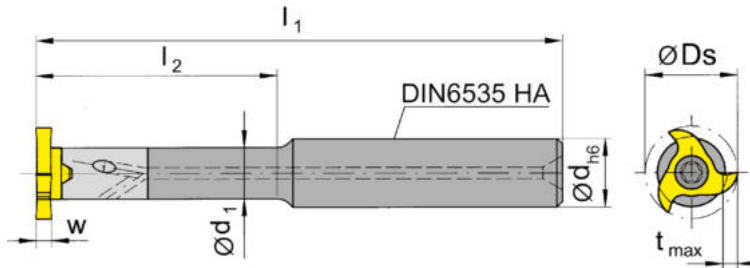
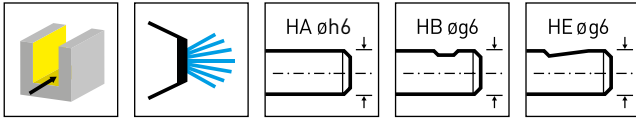

Bestellnummer Part number	d	l ₁	l ₂	d ₁	Form	HWS
M313.0012.01A	12	100	-	-	A	313113R • 313113L
M313.0012.02A	12	130	-	-	A	313113R • 313113L
M313.0016.02A	16	130	60	12	A	313113R • 313113L
M313.0016.03A	16	160	85	12	A	313113R • 313113L
M313.0012.01B	12	100	-	-	B	313113R • 313113L
M313.0012.02B	12	130	-	-	B	313113R • 313113L
M313.0016.01B	16	100	42	12	B	313113R • 313113L
M313.0016.02B	16	130	60	12	B	313113R • 313113L
M313.0016.03B	16	160	85	12	B	313113R • 313113L
M313.0012.01E	12	100	-	-	E	313113R • 313113L
M313.0012.02E	12	130	-	-	E	313113R • 313113L
M313.0016.01E	16	100	42	12	E	313113R • 313113L
M313.0016.02E	16	130	60	12	E	313113R • 313113L
M313.0016.03E	16	160	85	12	E	313113R • 313113L

w, Ds, tmax siehe Schneidplatte
w, Ds, tmax see inserts

Ersatzteile

Spare Parts

Fräuserschaft Milling shank	Spannschraube Clamping Screw	TORX PLUS®-Schlüssel TORX PLUS® Wrench
M313...	5.14T20P	T20PQ

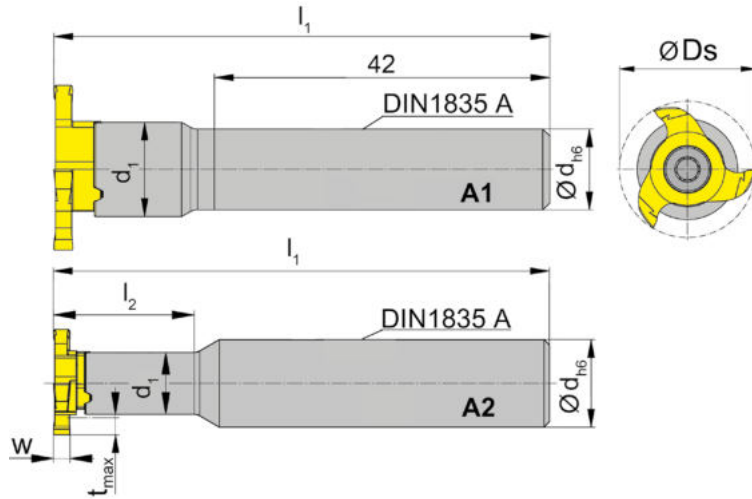
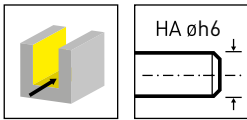

Bestellnummer Part number	d	l ₁	l ₂	d ₁	Form	HWS
M313.ST10.01A	10	60	-	11,3	A1	313113R • 313113L
M313.ST12.01A	12	70	18	11,3	A2	313113R • 313113L
M313.ST13.01A	13	70	26	11,3	A2	313113R • 313113L
M313.ST16.01A	16	80	26	11,3	A2	313113R • 313113L

w, Ds, t_{max} siehe Schneidplatte
w, Ds, t_{max} see inserts

Ersatzteile
Spare Parts

Frälerschaft Milling shank	Spannschraube Clamping Screw	TORX PLUS®-Schlüssel TORX PLUS® Wrench
M313...	5.14T20P	T20PQ

B

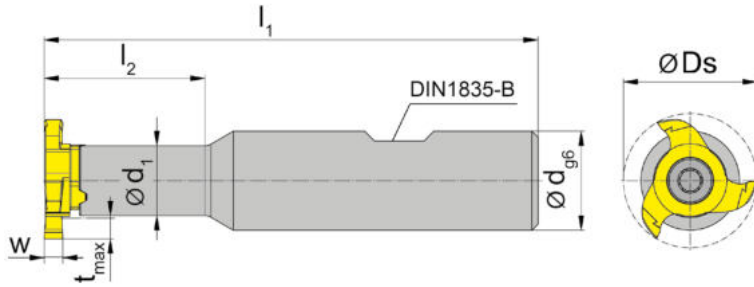
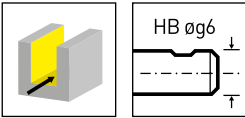

Bestellnummer Part number	d	l ₁	l ₂	d ₁	Form	HWS
M313.ST12.01B	12	70	18	11,3	B	313113R • 313113L
M313.ST16.01B	16	80	26	11,3	B	313113R • 313113L

w, Ds, tmax siehe Schneidplatte
w, Ds, tmax see inserts

Ersatzteile
Spare Parts

Fräserschaft Milling shank	Spannschraube Clamping Screw	TORX PLUS®-Schlüssel TORX PLUS® Wrench
M313...	5.14T20P	T20PQ

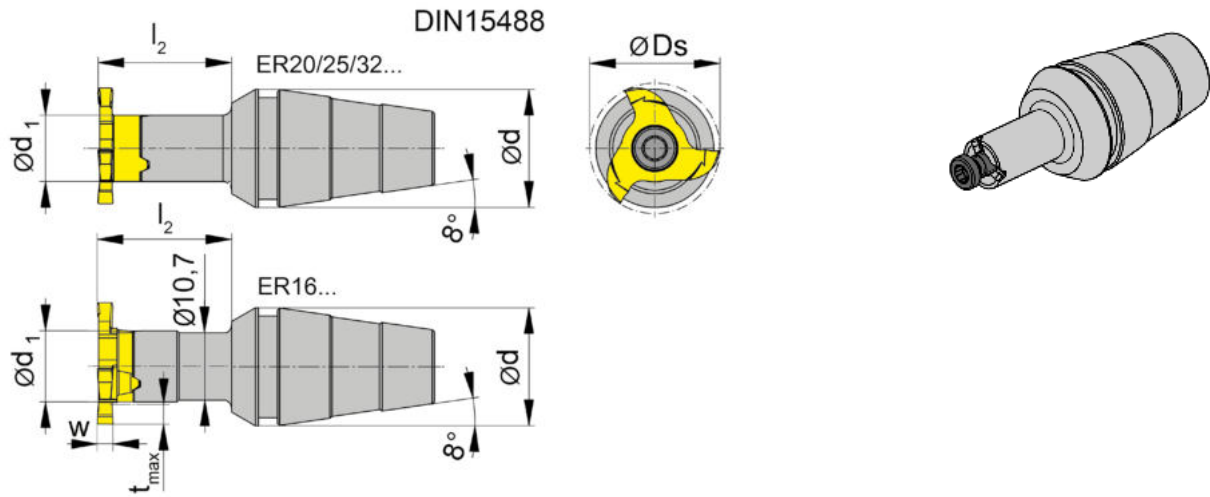

Bestellnummer Part number	d	l ₂	d ₁	Spannmutter Clamping nut	HWS
M313.ER16.01	16	20	11,3	ER16.6499/ERM16.6499	313113R • 313113L
M313.ER16.02	16	30	11,3	ER16.6499/ERM16.6499	313113R • 313113L
M313.ER20.01	20	20	11,3	ER20.6499/ERM20.6499	313113R • 313113L
M313.ER20.02	20	30	11,3	ER20.6499/ERM20.6499	313113R • 313113L
M313.ER25.02	25	30	11,3	ER25.6499	313113R • 313113L
M313.ER32.02	32	30	11,3	ER32.6499	313113R • 313113L

w, Ds, tmax siehe Schneidplatte
w, Ds, tmax see inserts

Spannmutter ist nicht im Lieferumfang enthalten - bitte separat bestellen!
Clamping nut is not combined with milling shank - separate order required!

Ersatzteile
Spare Parts

Fräuserschaft Milling shank	Spannschraube Clamping Screw	TORX PLUS®-Schlüssel TORX PLUS® Wrench
M313...	5.14T20P	T20PQ

B

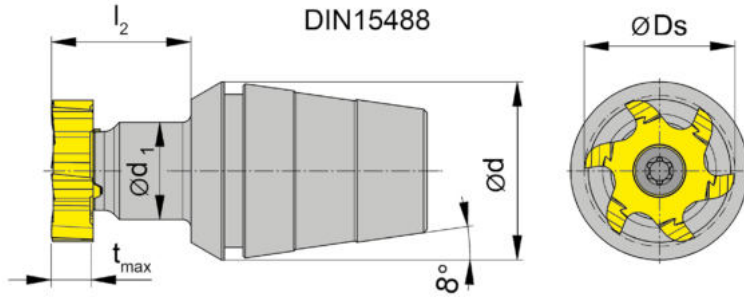
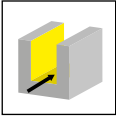

Bestellnummer Part number	d	l ₂	d ₁	Spannmutter Clamping nut	HWS
M313.ER25.14.01	25	19,7	14	ER25.6499	313113R • 313113L
M313.ER32.14.01	32	19,7	14	ER32.6499	313113R • 313113L

tmax und Ds siehe SP
tmax and Ds see inserts

Spannmutter ist nicht im Lieferumfang enthalten - bitte separat bestellen!
Clamping nut is not combined with milling shank - separate order required!

Ersatzteile

Spare Parts

Fräserschaft Milling shank	Spannschraube Clamping Screw	TORX PLUS®-Schlüssel TORX PLUS® Wrench
M313...	5.14T20P	T20PQ

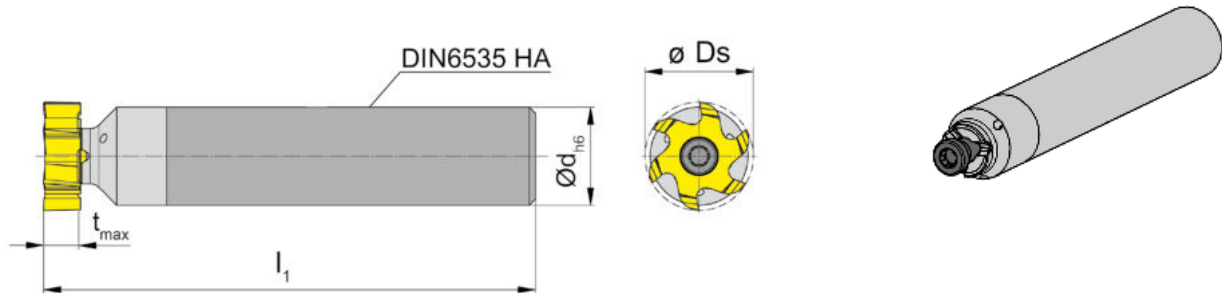
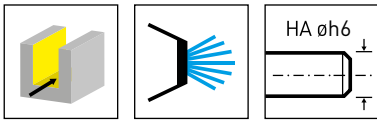

Bestellnummer Part number	d	l ₁	Form	HWS
M313.0016.D.00A	16	80	A	313113R • 313113L
M313.0020.D.00A	20	80	A	313113R • 313113L

tmax und Ds siehe SP
tmax and Ds see inserts

Ersatzteile
Spare Parts

Frälerschaft Milling shank	Spannschraube Clamping Screw	TORX PLUS®-Schlüssel TORX PLUS® Wrench
M313...	5.14T20P	T20PQ

B

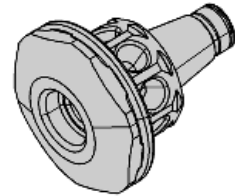
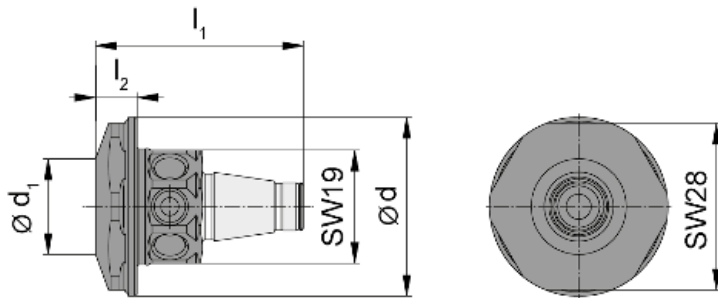

Bestellnummer Part number	l_1	l_2	d_1	d
WFB.2012.M081.01	35	7	16	30

für Einschraubfräser
for Screw-in cutter

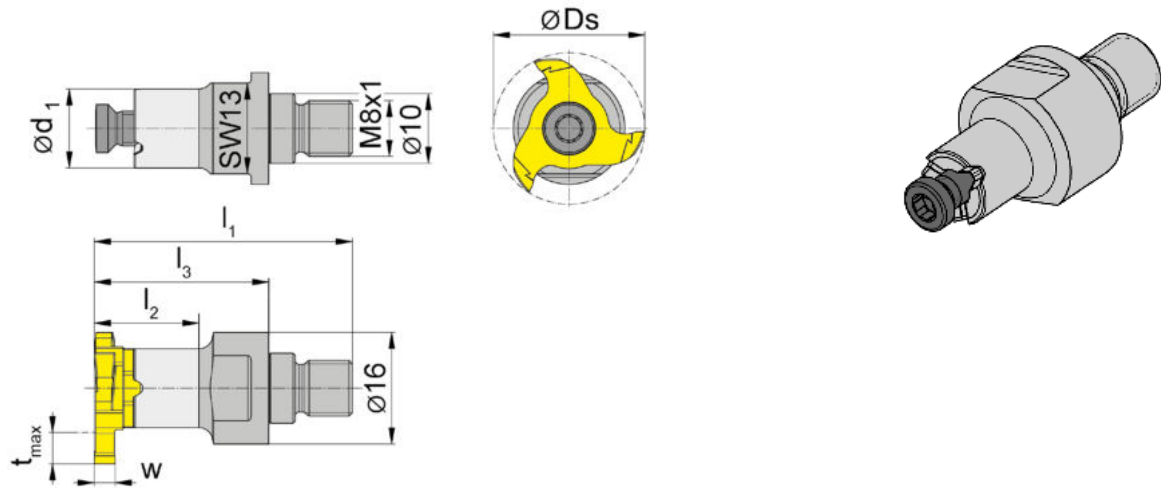
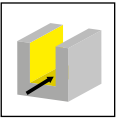

Bestellnummer Part number	l_1	l_2	l_3	d_1	SW	HWS	HMS
M313.M081.01	37	15	25	11,3	13	313113R • 313113L	8201

w, D_s , t_{max} siehe Schneidplatte
w, D_s , t_{max} see inserts

Ersatzteile
Spare Parts

Einschraubfräser Screw-in cutter	Spannschraube Clamping Screw	TORX PLUS®-Schlüssel TORX PLUS® Wrench
M313.M081.01	5.14T20P	T20PQ

B



Abbildung = rechtsschneidend
Picture = right hand cutting version

▲ ab Lager
on stock

HM-Sorten
Carbide grades
Δ 4 Wochen
4 weeks

Bestellnummer Part number	Ds	Nw	w	s	s ₁	t _{max}	Z	HIS	MG12	EG55	TN35
313.0070.00	21,7	0,7	0,77	5,9	5,6	1,5	3	313113R		▲	▲
313.0080.00	21,7	0,8	0,87	5,9	5,6	1,7	3	313113R		▲	▲
313.0090.00	21,7	0,9	0,97	5,9	5,6	1,9	3	313113R	Δ	▲	▲
313.0100.00	21,7	1	1,07	5,9	5,6	2,2	3	313113R		▲	▲
313.0110.00	21,7	1,1	1,21	5,9	5,6	2,5	3	313113R		▲	▲
									P	o	•
									M	-	o
									K	-	o
									N	-	-
									S	-	-
									H	-	-

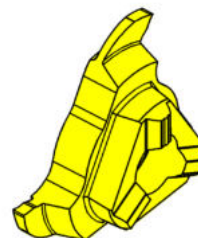
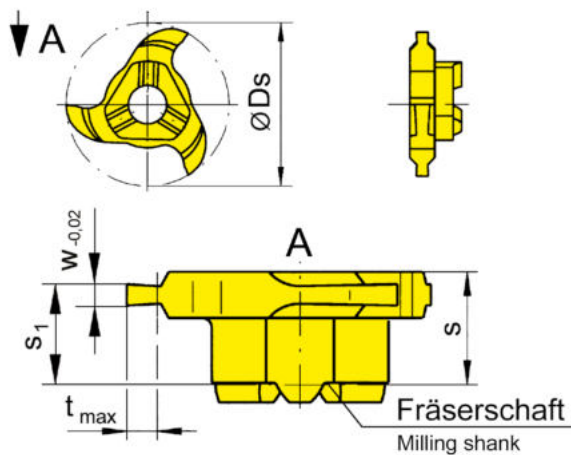
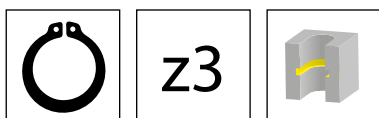

Abbildung = rechtsschneidend
Picture = right hand cutting version

▲ ab Lager
on stock

△ 4 Wochen
4 weeks

HM-Sorten
Carbide grades

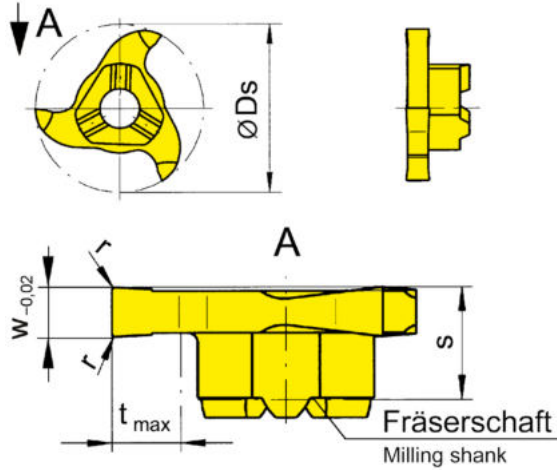
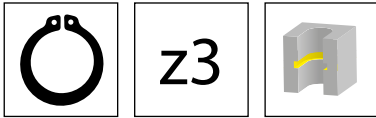
Bestellnummer Part number	Ds	Nw	w	s	r	t _{max}	Z	HIS	MG12	AS45	EG55	TN35
313.0130.00	21,7	1,3	1,41	5,7	-	4,5	3	313113R	▲	▲	▲	▲
313.0160.00	21,7	1,6	1,71	5,7	-	4,5	3	313113R	▲	▲	▲	▲
313.0185.00	21,7	1,85	1,96	5,7	0,2	4,5	3	313113R	▲	▲	▲	▲
313.0215.00	21,7	2,15	2,26	5,7	0,2	4,5	3	313113R	▲	▲	▲	▲
313.0265.00	21,7	2,65	2,76	5,7	0,2	4,5	3	313113R	▲	▲	▲	▲
313.0315.00	21,7	3,15	3,26	5,7	0,2	4,5	3	313113R	▲	▲	▲	▲
313.0415.00	21,7	4,15	4,26	5,7	0,2	4,5	3	313113R	▲	▲	▲	▲
313.0515.00	21,7	5,15	5,26	5,7	0,2	4,5	3	313113R	▲	▲	▲	▲

Bei Reduzierung der Frästiefe t_{max} ist eine Schneidbreite w bis 0,5 mm auf Anfrage möglich.
Inserts for widths of groove t_{max} down to 0,5 mm can be delivered with reduced depth upon request.

Schneidplatten 313.0415.00 und 313.0515.00

nur in Verbindung mit Fräserschaftabmessung l₂= max. 42 mm

Inserts 313.0415.00 and 313.0515.00

only with toolholder dimension l₂ = max. 42 mm

P	o	•	•	•
M	-	•	o	•
K	-	•	o	•
N	-	o	-	•
S	-	•	-	•
H	-	-	-	-

B



Abbildung = rechtsschneidend
Picture = right hand cutting version

▲ ab Lager
on stock

HM-Sorten
Carbide grades

Δ 4 Wochen
4 weeks

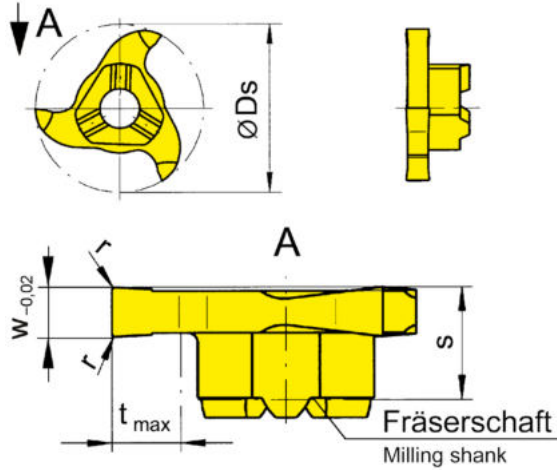
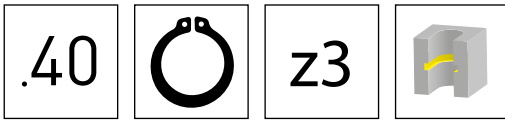
Bestellnummer Part number	Ds	Nw	w	s	r	t _{max}	Z	HIS	MG12	TI25
313.0130.40	21,7	1,3	1,41	5,7	-	4,5	3	313113R		▲
313.0160.40	21,7	1,6	1,71	5,7	-	4,5	3	313113R		▲
313.0185.40	21,7	1,85	1,96	5,7	0,2	4,5	3	313113R		▲
313.0215.40	21,7	2,15	2,26	5,7	0,2	4,5	3	313113R		▲
313.0265.40	21,7	2,65	2,76	5,7	0,2	4,5	3	313113R		▲
313.0315.40	21,7	3,15	3,26	5,7	0,2	4,5	3	313113R		▲
313.0415.40	21,7	4,15	4,26	5,7	0,2	4,5	3	313113R	Δ	▲
313.0515.40	21,7	5,15	5,26	5,7	0,2	4,5	3	313113R	Δ	▲

Schneidplatten 313.0415.40 und 313.0515.40
nur in Verbindung mit Fräserschaftabmessung l2= max. 42 mm
Inserts 313.0415.40 and 313.0515.40
only with toolholder dimension l2 = max. 42 mm

P	o	-
M	-	-
K	-	-
N	-	●
S	-	-
H	-	-



Abbildung = linksschneidend
Picture = left hand cutting version

▲ ab Lager
on stock

HM-Sorten
Carbide grades
Δ 4 Wochen
4 weeks

Bestellnummer Part number	Ds	Nw	w	s	r	t _{max}	Z	HIS	AS45	EG55	TI25
L313.0130.00	21,7	1,3	1,41	5,7	-	4,5	3	313113L	Δ	Δ	
L313.0160.00	21,7	1,6	1,71	5,7	-	4,5	3	313113L	Δ	Δ	
L313.0185.00	21,7	1,85	1,96	5,7	0,2	4,5	3	313113L	Δ	Δ	
L313.0215.00	21,7	2,15	2,25	5,7	0,2	4,5	3	313113L	Δ	Δ	Δ
L313.0265.00	21,7	2,65	2,76	5,7	0,2	4,5	3	313113L	Δ	Δ	
L313.0315.00	21,7	3,15	3,26	5,7	0,2	4,5	3	313113L	Δ	Δ	
L313.0415.00	21,7	4,15	4,26	5,7	0,2	4,5	3	313113L	Δ	Δ	
L313.0515.00	21,7	5,15	5,26	5,7	0,2	4,5	3	313113L	Δ	Δ	
P	●	●	●								
M	●	○	●								
K	●	○	●								
N	○	-	●								
S	●	-	●								
H	-	-	-								

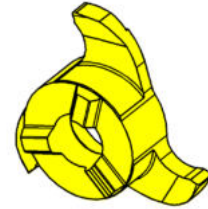
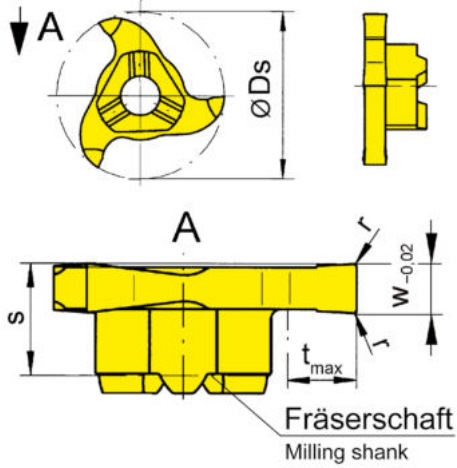
Bei Reduzierung der Frästiefe t_{max} ist eine Schneidbreite w bis 0,5 mm auf Anfrage möglich.
Inserts for widths of groove t_{max} down to 0,5 mm can be delivered with reduced depth upon request.

Schneidplatten L313.0415.00 und L313.0515.00
nur in Verbindung mit Fräserschaftabmessung l₂= max. 42 mm
Inserts L313.0415.00 and L313.0515.00
only with toolholder dimension l₂ = max. 42 mm

B



Abbildung = rechtsschneidend
Picture = right hand cutting version

▲ ab Lager
on stock

HM-Sorten
Carbide grades
Δ 4 Wochen
4 weeks

Bestellnummer Part number	Ds	Nw	w	t ₁	s	s ₁	r	t _{max}	Z	HIS	HM-Sorten Carbide grades					
											AS45	EG55	TA45	TN35		
313.1105.30	21,7	1,1	1,21	0,47	5,9	5,07	-	0,5	3	313113R		▲		▲		
313.1307.30	21,7	1,3	1,41	0,65	5,9	5,17	-	0,7	3	313113R	Δ	▲		▲		
313.1308.30	21,7	1,3	1,41	0,81	5,9	5,17	-	0,85	3	313113R		▲		▲		
313.1609.35	21,7	1,6	1,71	0,81	5,9	5,07	-	0,85	3	313113R		▲		▲		
313.1610.35	21,7	1,6	1,71	0,95	5,9	5,07	-	1	3	313113R	▲	▲		▲		
313.1812.35	21,7	1,85	1,96	1,21	5,9	5,19	0,2	1,25	3	313113R	▲	▲		▲		
313.2115.35	21,7	2,15	2,26	1,45	5,9	5,34	0,2	1,5	3	313113R	Δ	▲	Δ	▲		
313.2616.45	21,7	2,65	2,76	1,45	5,9	5,09	0,2	1,5	3	313113R	▲	▲		▲		
313.2617.45	21,7	2,65	2,76	1,7	5,9	5,09	0,2	1,75	3	313113R		▲		▲		
313.3118.45	21,7	3,15	3,26	1,7	5,9	5,34	0,2	1,75	3	313113R	Δ	▲		▲		
313.4120.55	21,7	4,15	4,26	1,95	5,9	5,34	0,2	2	3	313113R		▲		▲		
313.4125.55	21,7	4,15	4,26	2,45	5,9	5,34	0,2	2,5	3	313113R		▲		▲		
Schneidplatten 313.4120.55 und 313.4125.55												P	●	●	●	●
nur in Verbindung mit Fräaserschaftabmessung l ₂ = max. 42 mm												M	●	○	●	●
Inserts 313.4120.55 and 313.4125.55												K	●	○	●	●
only with toolholder dimension l ₂ = max. 42 mm												N	○	-	●	●
												S	●	-	●	●
												H	-	-	-	-

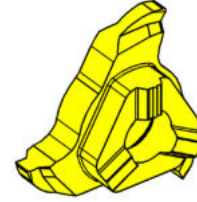
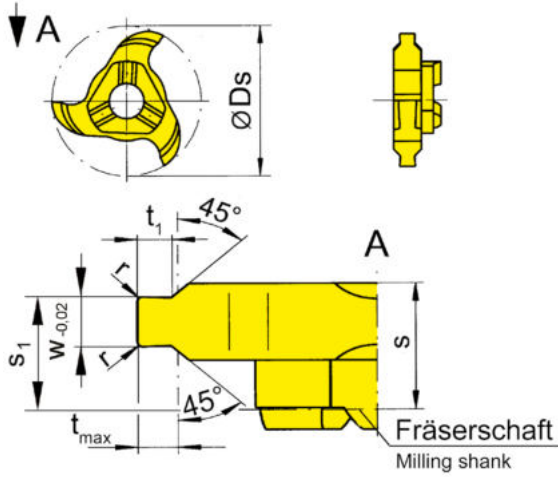
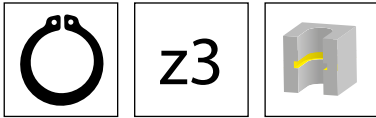

Abbildung = rechtsschneidend
Picture = right hand cutting version

▲ ab Lager
on stock

HM-Sorten
Carbide grades

△ 4 Wochen
4 weeks

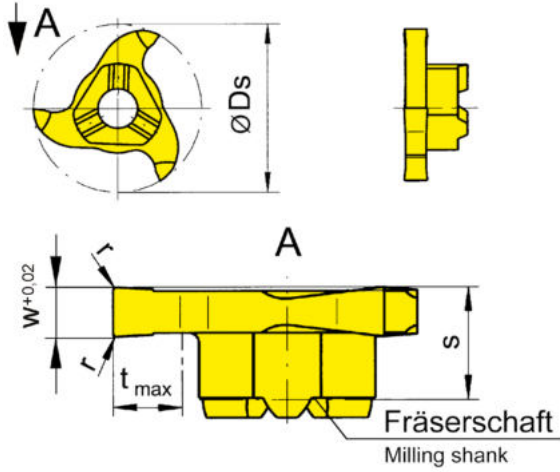
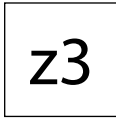
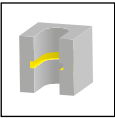
Bestellnummer Part number	Ds	w	s	r	t _{max}	Z	HIS	MG12	AS45	EG55	TI25	TN35
313.0150.00	21,7	1,5	5,7	-	4,5	3	313113R	▲	▲	▲		▲
313.0150.01	21,7	1,5	5,7	0,1	4,5	3	313113R		▲	▲		
313.0200.00	21,7	2	5,7	0,2	4,5	3	313113R	▲	▲	▲		▲
313.0250.00	21,7	2,5	5,7	0,2	4,5	3	313113R	△	▲	▲	▲	▲
313.0300.00	21,7	3	5,7	0,2	4,5	3	313113R	▲	▲	▲		▲
313.0350.00	21,7	3,5	5,7	0,2	4,5	3	313113R	△	▲	▲	▲	
313.0400.00	21,7	4	5,7	0,2	4,5	3	313113R	▲	▲	▲		▲
313.0500.00	21,7	5	5,7	0,2	4,5	3	313113R		▲	▲		▲
313.0600.00	21,7	6	6,9	0,2	4,5	3	313113R	△	▲	▲		▲

Bei Reduzierung der Frästiefe t_{max} ist eine Schneidbreite w bis 0,5 mm auf Anfrage möglich.
Inserts for widths of groove t_{max} down to 0,5 mm can be delivered with reduced depth upon request.

Schneidplatte **313.0600.00** mit Spanteilern!
Insert 313.0600.00 with chip divider!

P	o	•	•	•	•
M	-	•	o	•	•
K	-	•	o	•	•
N	-	o	-	•	•
S	-	•	-	•	•
H	-	-	-	-	-

B



Abbildung = rechtsschneidend
Picture = right hand cutting version

HM-Sorten
Carbide grades
▲ ab Lager
on stock
Δ 4 Wochen
4 weeks

Bestellnummer Part number	Ds	w	s	r	t _{max}	Z	HIS	T125
313.0150.40	21,7	1,5	5,7	-	4,5	3	313113R	▲
313.0200.40	21,7	2	5,7	0,2	4,5	3	313113R	▲
313.0250.40	21,7	2,5	5,7	0,2	4,5	3	313113R	▲
313.0300.40	21,7	3	5,7	0,2	4,5	3	313113R	▲
313.0400.40	21,7	4	5,7	0,2	4,5	3	313113R	▲
								P -
								M -
								K -
								N ●
								S -
								H -

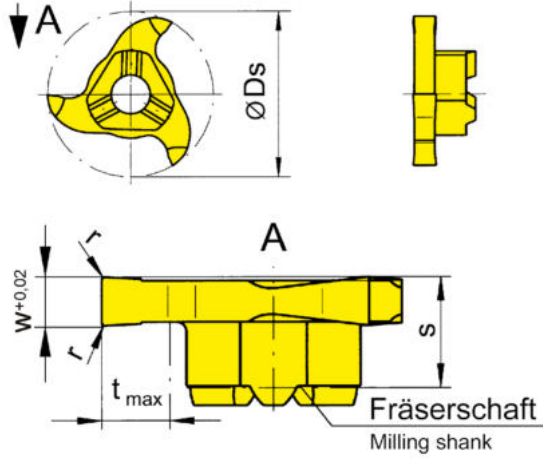
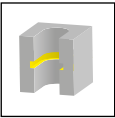

z3

B



Abbildung = linksschneidend
Picture = left hand cutting version

▲ ab Lager
on stock

HM-Sorten
Carbide grades
Δ 4 Wochen
4 weeks

Bestellnummer Part number	Ds	w	s	r	t _{max}	Z	HIS	HM-Sorten Carbide grades				
								MG12	AS45	EG55	TI25	
L313.0150.00	21,7	1,5	5,7	-	4,5	3	313113L		Δ	Δ		
L313.0150.01	21,7	1,5	5,7	0,1	4,5	3	313113L		Δ	Δ		
L313.0200.00	21,7	2	5,7	0,2	4,5	3	313113L		Δ	Δ		
L313.0250.00	21,7	2,5	5,7	0,2	4,5	3	313113L		Δ	Δ	Δ	
L313.0300.00	21,7	3	5,7	0,2	4,5	3	313113L		Δ	Δ	Δ	
L313.0350.00	21,7	3,5	5,7	0,2	4,5	3	313113L		Δ	Δ	Δ	
L313.0400.00	21,7	4	5,7	0,2	4,5	3	313113L		▲	Δ		
L313.0500.00	21,7	5	5,7	0,2	4,5	3	313113L		Δ	Δ		
L313.0600.00	21,7	6	6,9	0,2	4,5	3	313113L	Δ	Δ	Δ		
								P	o	•	•	•
								M	-	•	o	•
								K	-	•	o	•
								N	-	o	-	•
								S	-	•	-	•
								H	-	-	-	-

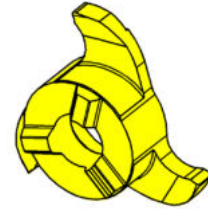
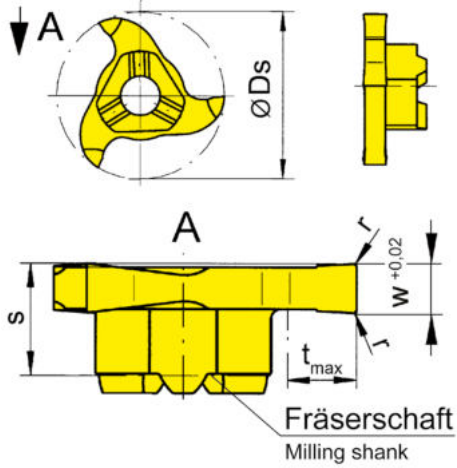
Bei Reduzierung der Frästiefe t_{max} ist eine Schneidbreite w bis 0,5 mm auf Anfrage möglich.
Inserts for widths of groove t_{max} down to 0,5 mm can be delivered with reduced depth upon request.

B



z3



Abbildung = rechtsschneidend
Picture = right hand cutting version

▲ ab Lager
on stock

HM-Sorten
Carbide grades
Δ 4 Wochen
4 weeks

Bestellnummer Part number	Ds	w	s	t _{max}	Z	HIS	EG55	TI25	TN35
313.0100.1.00	21,7	1	5,7	4,5	3	313113R	▲	▲	▲
							P ●	●	●
							M ○	●	●
							K ○	●	●
							N -	●	●
							S -	●	●
							H -	-	-

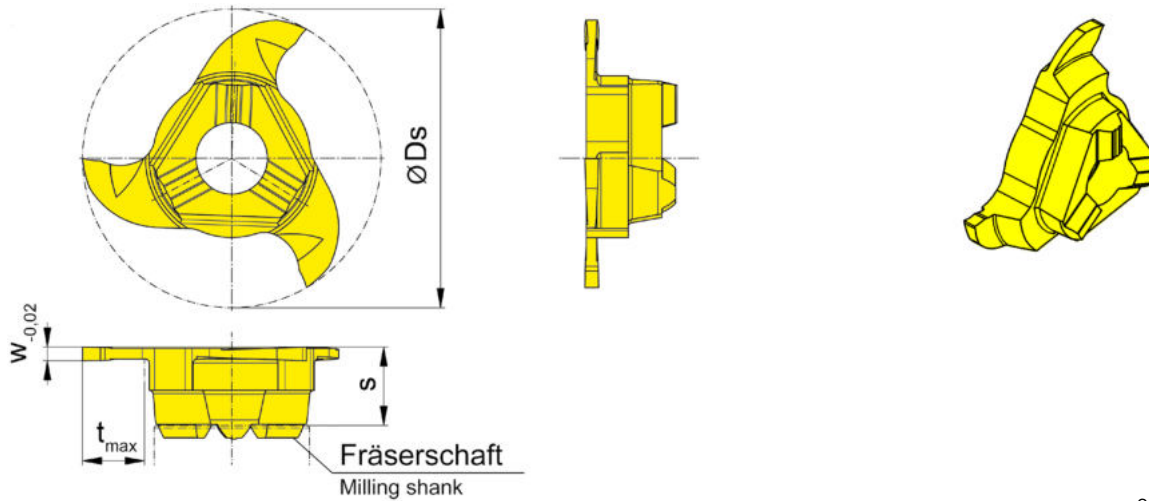

Abbildung = rechtsschneidend
Picture = right hand cutting version

▲ ab Lager
on stock

HM-Sorten
Carbide grades
Δ 4 Wochen
4 weeks

Bestellnummer Part number	Ds	w	s	r	t _{max}	Z	HIS	HM-Sorten Carbide grades			
								AS45	EG55	TN35	
313.0005.10	21,7	1	5,7	0,5	4,5	3	313113R	▲	▲	▲	
313.0007.15	21,7	1,5	5,7	0,75	4,5	3	313113R	▲	▲	▲	
313.0010.20	21,7	2	5,7	1	4,5	3	313113R	▲	▲	▲	
313.0014.28	21,7	2,8	5,7	1,4	4,5	3	313113R	▲	▲	▲	
313.0015.30	21,7	3	5,7	1,5	4,5	3	313113R	▲	▲	▲	
313.0020.40	21,7	4	5,7	2	4,5	3	313113R	▲	▲	▲	
313.0025.50	21,7	5	5,7	2,5	4,5	3	313113R	▲	▲	▲	
								P	●	●	●
								M	●	○	●
								K	●	○	●
								N	○	-	●
								S	●	-	●
								H	-	-	-

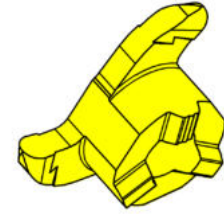
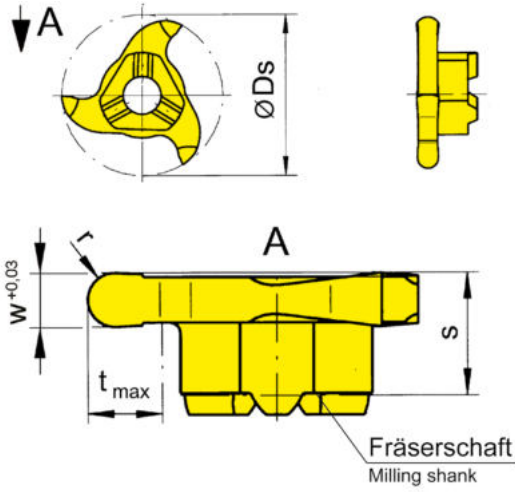
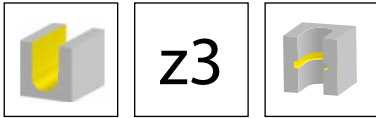
B



Abbildung = rechtsschneidend
Picture = right hand cutting version

▲ ab Lager
on stock

HM-Sorten
Carbide grades
Δ 4 Wochen
4 weeks

Bestellnummer Part number	Ds	E	s	w	t _{max}	Z	HIS	EG55	TA45	TN35
313.4545.00	21,7	2,15	7,1	3	1,7	3	313113R	▲	▲	▲
313.4545.30.00	21,7	3,6	9,4	2,6	3	3	313113R	▲	▲	▲
P	●	●	●	●	●	●	●	●	●	●
M	○	○	○	○	○	○	○	○	○	○
K	○	○	○	○	○	○	○	○	○	○
N	-	○	○	○	○	○	○	○	○	○
S	-	○	○	○	○	○	○	○	○	○
H	-	-	-	-	-	-	-	-	-	-

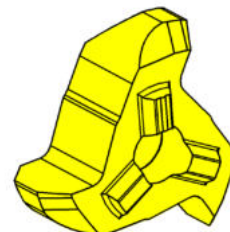
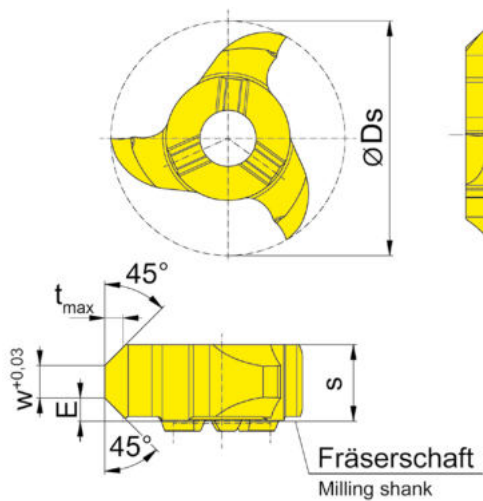
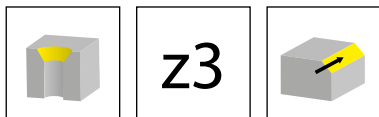
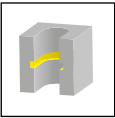

z6

B



Abbildung = rechtsschneidend
Picture = right hand cutting version

▲ ab Lager
on stock

HM-Sorten
Carbide grades

Δ 4 Wochen
4 weeks

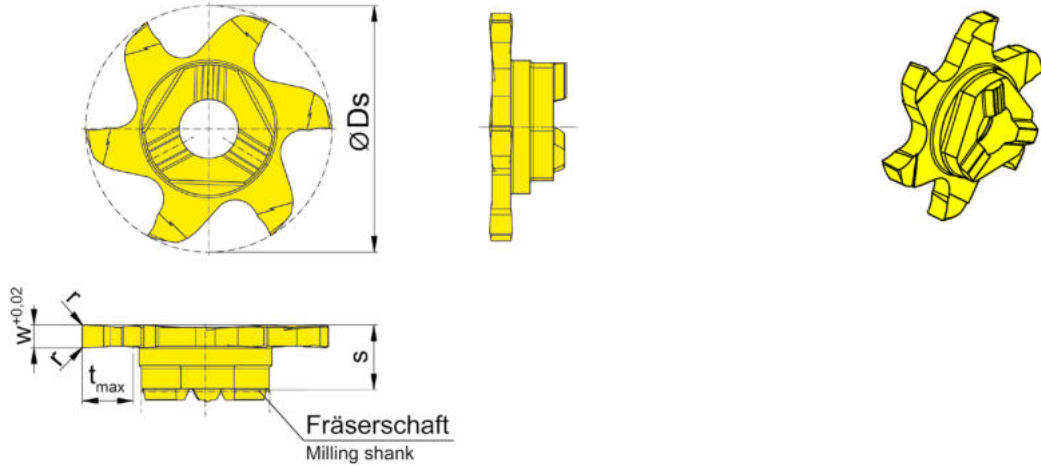
Bestellnummer Part number	D_s	w	s	r	t_{max}	Z	HIS	AS45	EG55	TI25	
613.0150.00	21,7	1,5	5,7	-	4,5	6	313113R	Δ	▲	▲	
613.0200.00	21,7	2	5,7	0,2	4,5	6	313113R	▲	▲	▲	
613.0250.00	21,7	2,5	5,7	0,2	4,5	6	313113R	▲	▲	▲	
613.0300.00	21,7	3	5,7	0,2	4,5	6	313113R	▲	▲	▲	
613.0400.00	21,7	4	5,7	0,2	4,5	6	313113R	▲	▲	▲	
ab Schneidbreite 2,5 mm Kreuzverzahnung from width of groove 2,5 mm toothing with cross-cut								P	●	●	●
Schneidplatte 613.0400.00								M	●	○	●
nur in Verbindung mit Fräaserschaftabmessung $l_2 = \text{max. } 42 \text{ mm}$ Insert 613.0400.00								K	●	○	●
only with toolholder dimension $l_2 = \text{max. } 42 \text{ mm}$								N	○	-	●
								S	●	-	●
								H	-	-	-

B



Z6



Abbildung = rechtsschneidend
Picture = right hand cutting version

▲ ab Lager
on stock

HM-Sorten
Carbide grades
Δ 4 Wochen
4 weeks

Bestellnummer Part number	Ds	Nw	w	s	t _{max}	Z	HIS	AS45	EG55
613.0130.00	21,7	1,3	1,41	5,7	4,5	6	313113R	▲	▲
613.0215.00	21,7	2,15	2,26	5,7	4,5	6	313113R	▲	▲
613.0315.00	21,7	3,15	3,26	5,7	4,5	6	313113R	▲	▲
613.0415.00	21,7	4,15	4,26	5,7	4,5	6	313113R	▲	▲
613.0515.00	21,7	5,15	5,26	5,7	4,5	6	313113R	▲	▲

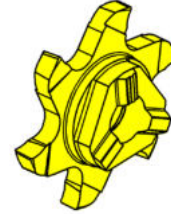
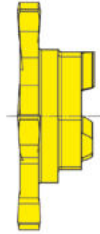
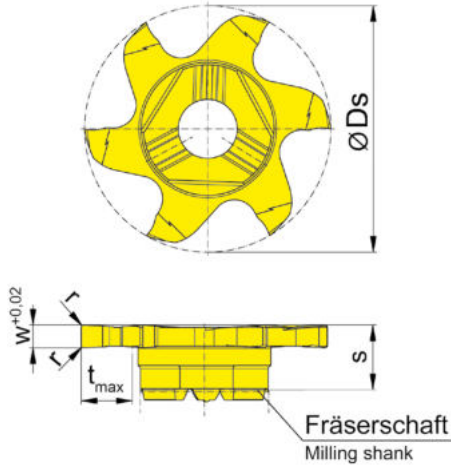
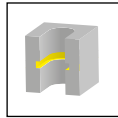
Bei Reduzierung der Frästiefe t_{max} ist eine Schneidbreite w bis 0,5 mm auf Anfrage möglich.
Inserts for widths of groove t_{max} down to 0,5 mm can be delivered with reduced depth upon request.

P	●	●
M	●	○
K	●	○
N	○	-
S	●	-
H	-	-



Abbildung = rechtsschneidend
Picture = right hand cutting version

HM-Sorten
Carbide grades
▲ ab Lager
on stock
Δ 4 Wochen
4 weeks

Bestellnummer Part number	Ds	Nw	w	t ₁	s	s ₁	r	t _{max}	Z	HIS	AS45	EG55
613.1812.35	21,7	1,85	1,96	1,21	5,9	4,7	0,2	1,25	6	313113R	▲	▲
613.2115.35	21,7	2,15	2,26	1,45	5,9	4,9	0,2	1,5	6	313113R	Δ	▲
											P ● ●	● ●
											M ● ●	● ●
											K ● ●	● ●
											N ○ -	-
											S ● -	-
											H - -	-

B

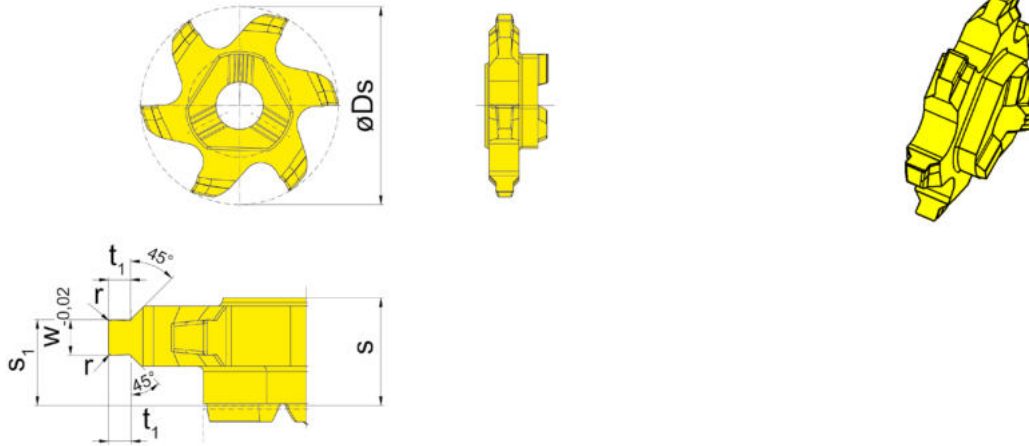
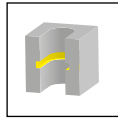
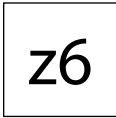
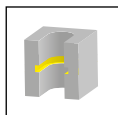

z6



Abbildung = rechtsschneidend
Picture = right hand cutting version

▲ ab Lager
on stock

HM-Sorten
Carbide grades
Δ 4 Wochen
4 weeks

Bestellnummer Part number	Ds	w	s	t _{max}	Z	HIS	EG55	TI25
613.0100.1.00	21,7	1	5,7	4,5	6	313113R	▲	▲
613.0100.1.00	21,7	1	5,7	4,5	6	313113R	▲	▲
							P ● ●	
							M ○ ●	
							K ○ ●	
							N - ●	
							S - ●	
							H - -	

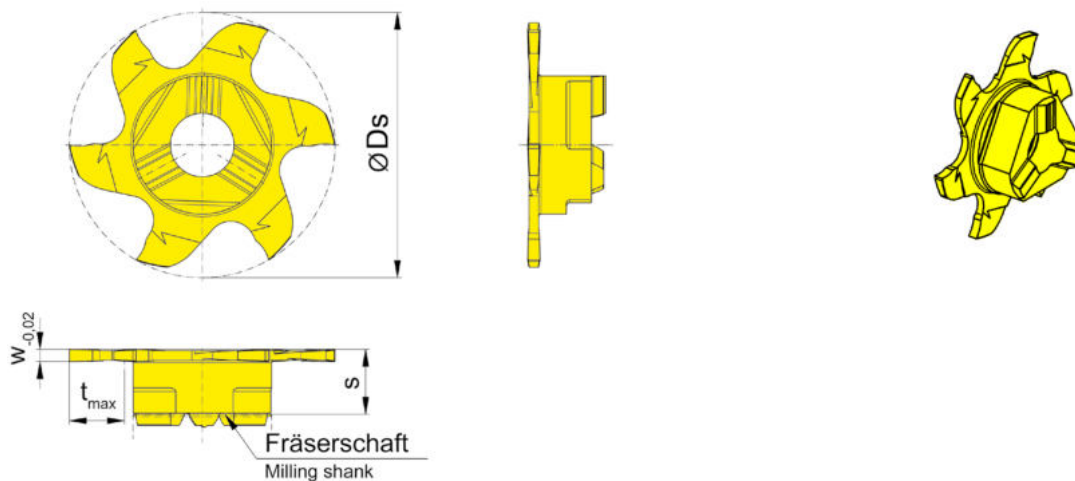

Abbildung = rechtsschneidend
Picture = right hand cutting version

▲ ab Lager
on stock

HM-Sorten
Carbide grades

Δ 4 Wochen
4 weeks

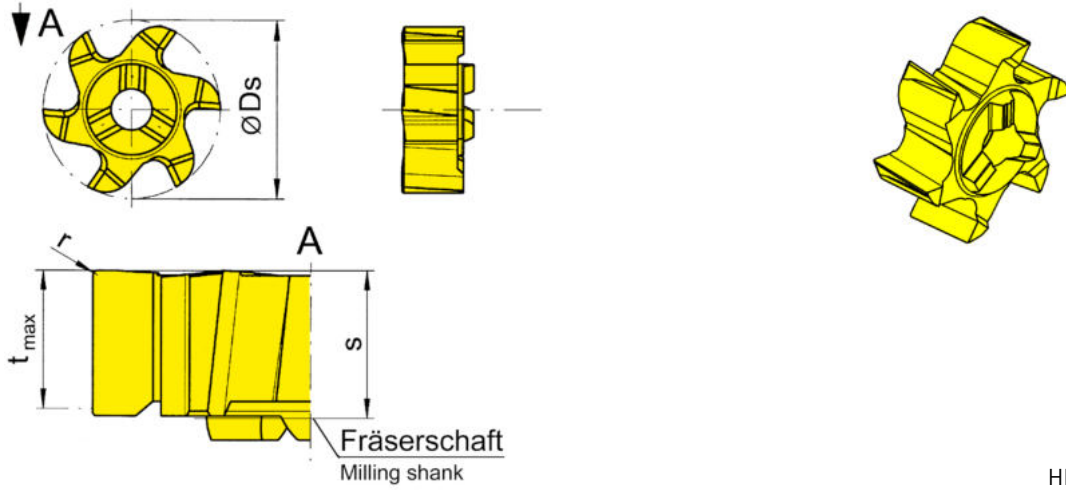
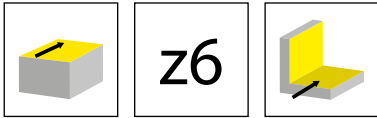
Bestellnummer Part number	Ds	Z	r	t _{max}	s	HIS	HM-Sorten Carbide grades			
							AS45	EG55	TF45	TI25
613.PL61.62	21,7	6	0,2	5,7	6,1	313113R	▲	▲	▲	▲
							P	●	●	●
							M	●	○	●
							K	●	○	●
							N	○	-	●
							S	●	-	●
							H	-	-	-

B



Abbildung = rechtsschneidend
Picture = right hand cutting version

▲ ab Lager
on stock

HM-Sorten
Carbide grades
Δ 4 Wochen
4 weeks

Bestellnummer Part number	Ds	Z	r	t _{max}	s	HIS	AS45	EG55	T125
613.PLT6.15	21,7	6	1,5	5,7	6,1	313113R	▲	▲	Δ
P	●	●	●						
M	●	○	●						
K	●	○	●						
N	○	-	●						
S	●	-	●						
H	-	-	-						

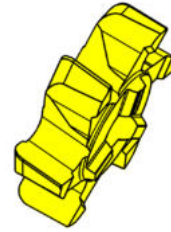
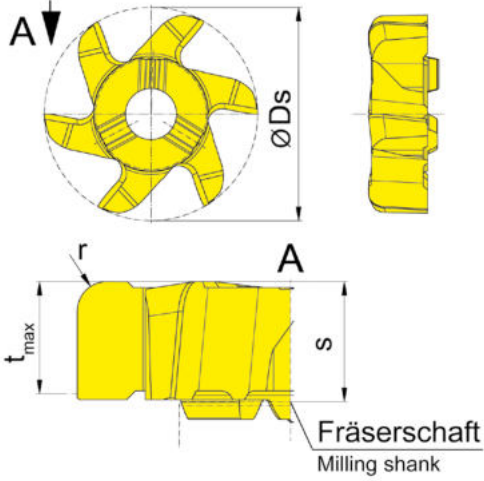
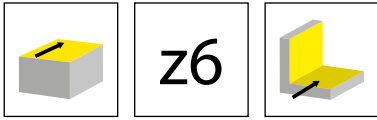

Abbildung = rechtsschneidend
Picture = right hand cutting version

▲ ab Lager
on stock

HM-Sorten
Carbide grades
Δ 4 Wochen
4 weeks

Bestellnummer Part number	Ds	Z	r	α	t_{max}	s	HIS	AS45	EG55
613.0015.25	21,7	6	0,5	15°	1,1	5,7	313113R	▲	▲
613.0030.25	21,7	6	0,5	30°	2,3	5,7	313113R	▲	▲
613.0045.25	21,7	6	0,5	45°	3,5	5,7	313113R	▲	▲
								P	● ●
								M	● ●
								K	● ●
								N	○ ○
								S	● ●
								H	- -

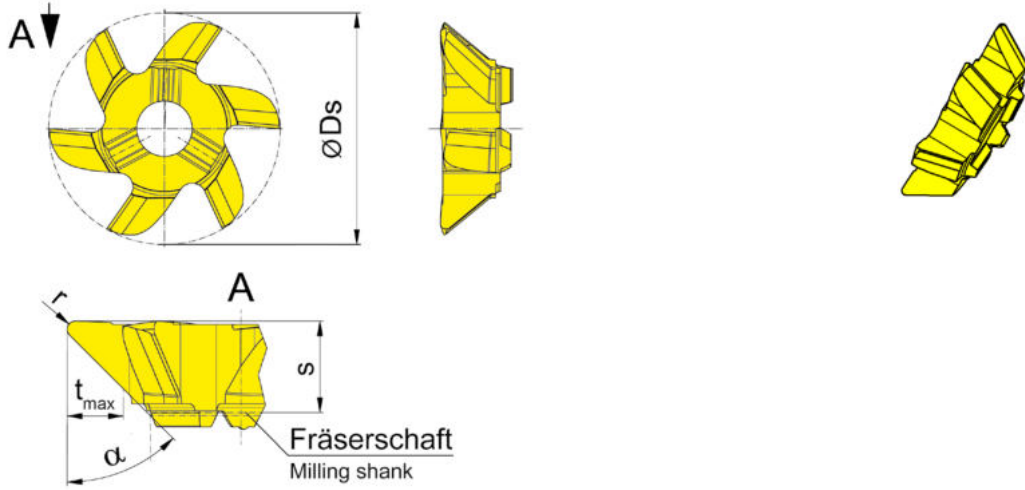
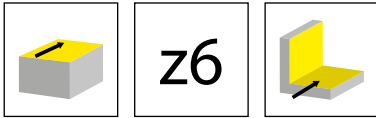
B

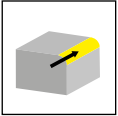

z6



Abbildung = rechtsschneidend
Picture = right hand cutting version

HM-Sorten
Carbide grades
▲ ab Lager
on stock
Δ 4 Wochen
4 weeks

Bestellnummer Part number	Ds	w	s	s ₁	r	Z	HIS	AS/45
613.R100.00	21,7	1,5	6,3	4	1	6	313113R	▲
613.R150.00	21,7	1,5	7,6	4,6	1,5	6	313113R	▲
613.R200.00	21,7	1,5	9,4	5,5	2	6	313113R	▲
613.R250.00	21,7	1,5	9,9	5,75	2,5	6	313113R	▲
613.R300.00	21,7	1,5	9,9	5,75	3	6	313113R	▲
								P ●
								M ●
								K ●
								N ○
								S ●
								H -

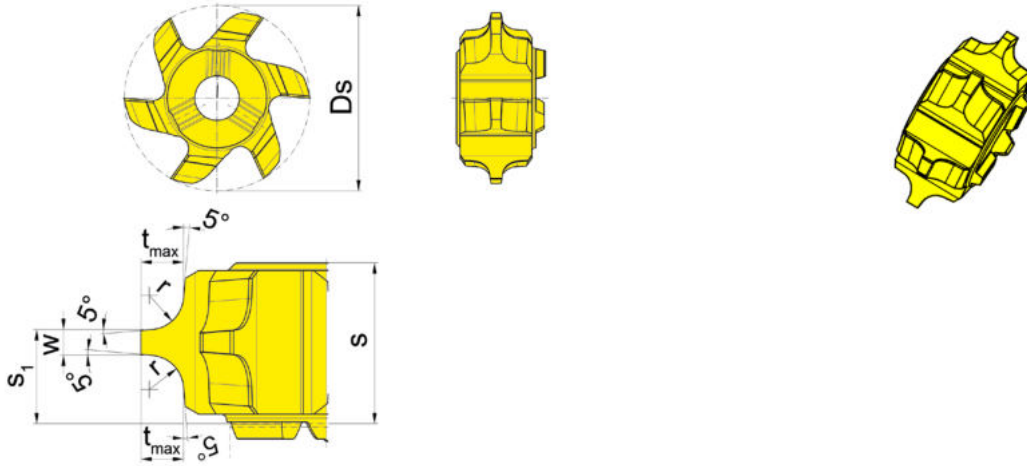

Abbildung = rechtsschneidend
Picture = right hand cutting version

▲ ab Lager
on stock

HM-Sorten
Carbide grades
Δ 4 Wochen
4 weeks

Bestellnummer Part number	Ds	E	s	w	α	b	t _{max}	Z	HIS	EG55	TA45	TI25
613.1515.20	21,7	3,3	6,3	0,2	15°	2,7	0,75	6	313113R	▲	▲	
613.2020.20	21,7	3,3	6,3	0,2	20°	2,7	1	6	313113R	▲	▲	
613.3030.20	21,7	3,3	6,3	0,2	30°	2,7	1,6	6	313113R	▲	▲	
613.4545.20	21,7	3,3	6,3	0,2	45°	2,5	2,5	6	313113R	▲		▲
										P	●	●
										M	○	●
										K	○	●
										N	-	●
										S	-	●
										H	-	-

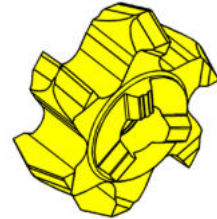
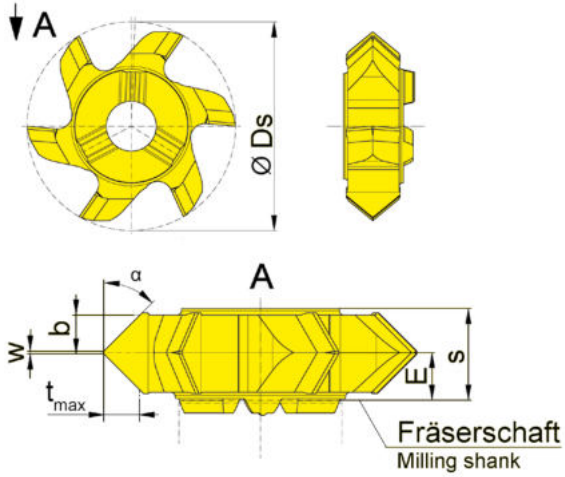
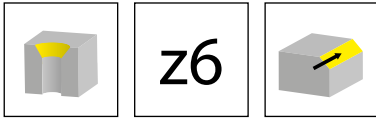
B



Abbildung = rechtsschneidend
Picture = right hand cutting version

HM-Sorten
Carbide grades
▲ ab Lager
on stock
Δ 4 Wochen
4 weeks

Bestellnummer Part number	Ds	E	s	r	t _{max}	Z	HIS	AS45
613.6060.05	21,7	3,2	6,3	0,05	4	6	313113R	▲
								P ●
								M ●
								K ●
								N ○
								S ●
								H -

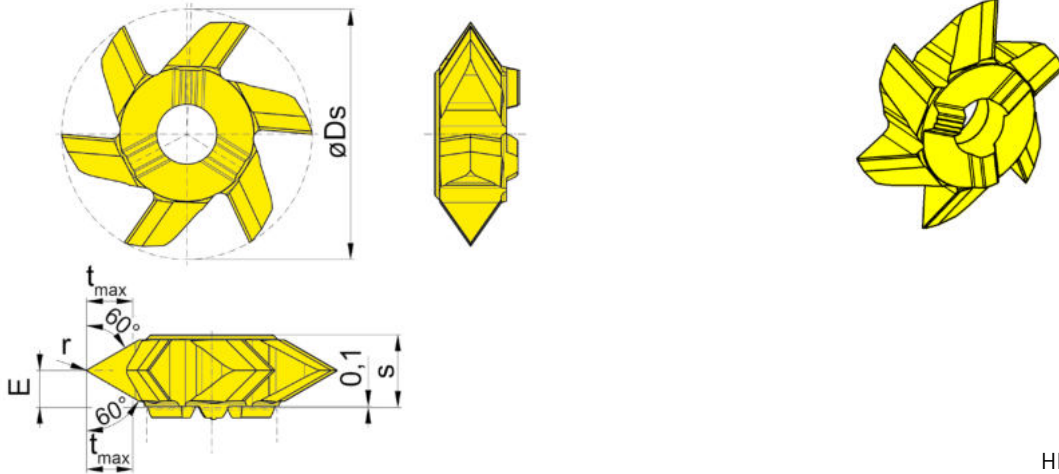
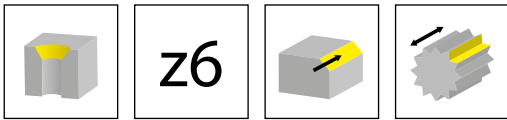
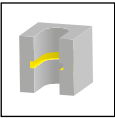

z12

B



Abbildung = rechtsschneidend
Picture = right hand cutting version

▲ ab Lager
on stock

HM-Sorten
Carbide grades

△ 4 Wochen
4 weeks

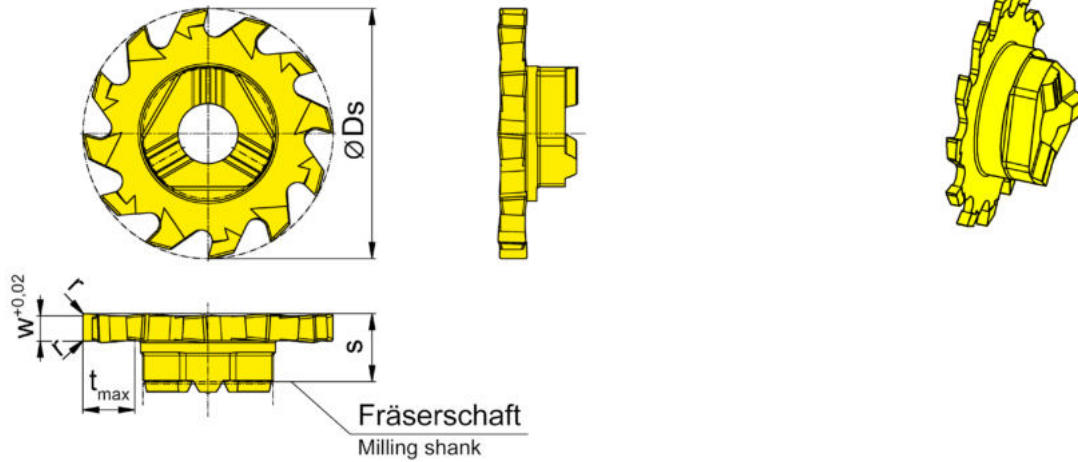
Bestellnummer Part number	Ds	w	s	r	t _{max}	Z	HIS	HM-Sorten Carbide grades					
								AN25	AS45	EG35	EG55	IG35	TI25
713.0025.00	21,7	0,25	5,9	-	2,3	12	313113R			▲		△	
713.0030.00	21,7	0,3	5,9	-	2,3	12	313113R			▲		△	
713.0040.00	21,7	0,4	5,9	-	2,3	12	313113R	△	△		▲		
713.0050.00	21,7	0,5	5,9	-	2,8	12	313113R	△			▲		
713.0060.00	21,7	0,6	5,9	-	4,5	12	313113R			▲		△	
713.0070.00	21,7	0,7	5,9	-	4,5	12	313113R			▲		△	
713.0080.00	21,7	0,8	5,9	-	4,5	12	313113R	△			▲		
713.0090.00	21,7	0,9	5,9	-	4,5	12	313113R			▲		△	
713.0100.00	21,7	1	5,9	-	4,5	12	313113R				▲		▲
713.0150.00	21,7	1,5	5,9	-	4,5	12	313113R				▲		▲
713.0200.00	21,7	2	5,9	0,2	4,5	12	313113R				▲		▲
713.0250.00	21,7	2,5	5,9	0,2	4,5	12	313113R				▲		▲
713.0300.00	21,7	3	5,9	0,2	4,5	12	313113R				▲		▲

ab Schneidbreite 2 mm Kreuzverzahnung
from width of groove 2 mm tooting with cross-cut

P	●	●	●	●	-	●
M	○	●	●	○	●	●
K	-	●	○	○	-	●
N	-	○	-	-	-	●
S	-	●	-	-	●	●
H	-	-	-	-	-	-

B



Abbildung = rechtsschneidend
Picture = right hand cutting version

▲ ab Lager
on stock

HM-Sorten
Carbide grades
Δ 4 Wochen
4 weeks

Bestellnummer Part number	D_s	Z	r	t_{max}	s	HIS	EG55	TI25
713.PL35.15.02	21,7	12	0,2	3,5	5,9	313113R	▲	▲

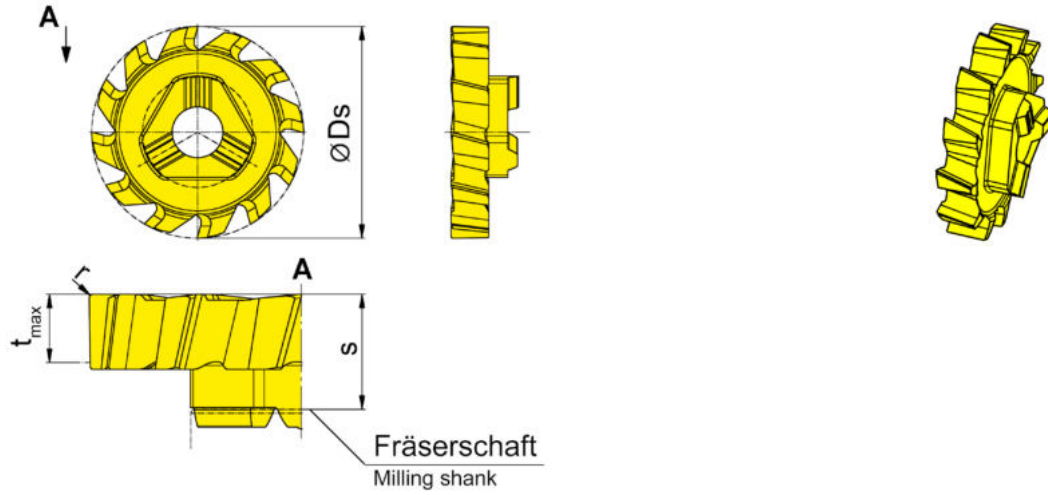
Schrägverzahnung
Helical teeth

P	●	●
M	○	●
K	○	●
N	-	●
S	-	●
H	-	-

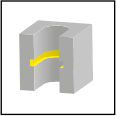

z9

B



Abbildung = rechtsschneidend
Picture = right hand cutting version

HM-Sorten
Carbide grades
▲ ab Lager
on stock
Δ 4 Wochen
4 weeks

Bestellnummer Part number	Ds	w	s	b x 45°	r	t _{max}	Z	HIS	EG55	IG65
913.0150.00	21,7	1,5	5,7	0,05	-	4,5	9	313113R	▲	Δ
913.0200.00	21,7	2	5,7	-	0,2	4,5	9	313113R	▲	Δ
913.0250.00	21,7	2,5	5,7	-	0,2	4,5	9	313113R	▲	Δ
913.0300.00	21,7	3	5,7	-	0,2	4,5	9	313113R	▲	Δ
									P ● ●	
									M ○ ●	
									K ○ -	
									N - -	
									S - ○	
									H - -	

Nutfräsen (zirkular)

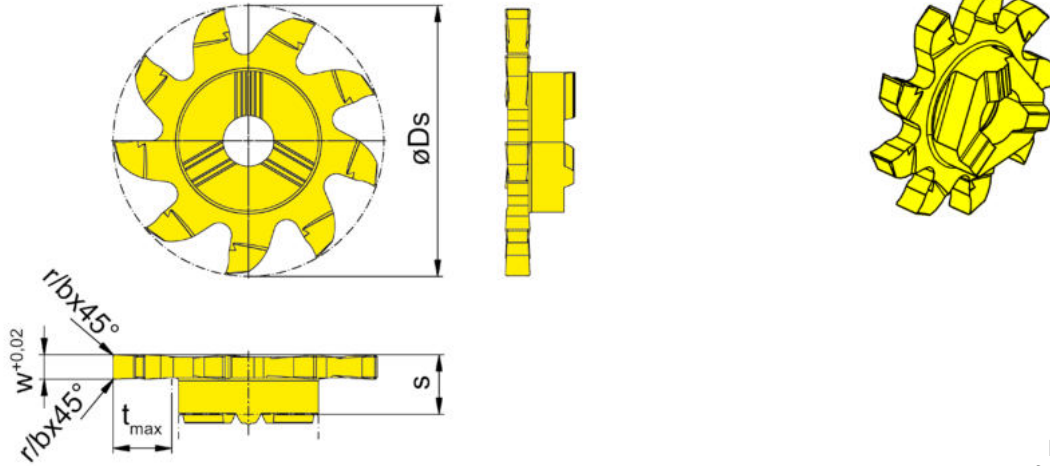
Groove Milling by circular interpolation



B

Frälerschaft
Milling shank
M328/M328.ST/M328.ER

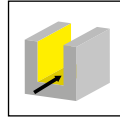

Seite/Page
152-157

Grundaufnahme
Basic Holder
WFB

Seite/Page
158

Einschraubfräser
Screw-in cutter
M328.M

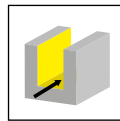

Seite/Page
159

Schneidplatte
Insert
325/328/628/928

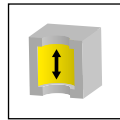

Seite/Page
160

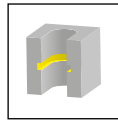

Seite/Page
161, 164-165,
170-172, 175

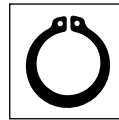

Seite/Page
162, 169



Seite/Page
163

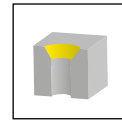

Seite/Page
166, 174

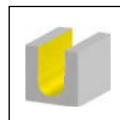

Seite/Page
167-168

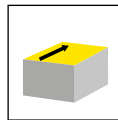

Seite/Page
173

M328



**Fräser mit wechselbarer
Schneidplatte**

ab Bohrung \varnothing 28 mm

**Milling shank with
exchangeable insert**

from bore \varnothing 28 mm

Fräuserschaft

Milling shank

M328



B

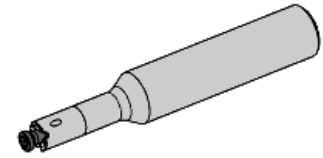
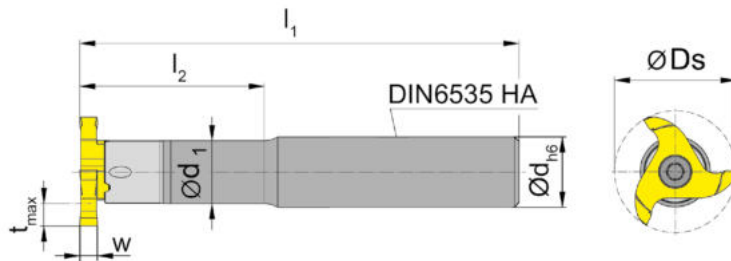
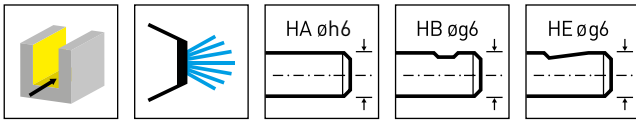

Bestellnummer Part number	d	l ₁	l ₂	d ₁	Form	HWS
M328.0016.01A	16	100	42	14,3	A	328143R
M328.0016.02A	16	130	60	14,3	A	328143R
M328.0016.03A	16	160	85	14,3	A	328143R
M328.0020.01A	20	100	42	14,3	A	328143R
M328.0020.02A	20	130	60	14,3	A	328143R
M328.0020.03A	20	160	85	14,3	A	328143R
M328.0016.01B	16	100	42	14,3	B	328143R
M328.0016.02B	16	130	60	14,3	B	328143R
M328.0016.03B	16	160	85	14,3	B	328143R
M328.0020.01B	20	100	42	14,3	B	328143R
M328.0020.02B	20	130	60	14,3	B	328143R
M328.0020.03B	20	160	85	14,3	B	328143R
M328.0016.01E	16	100	42	14,3	E	328143R
M328.0016.02E	16	130	60	14,3	E	328143R
M328.0016.03E	16	160	85	14,3	E	328143R
M328.0020.01E	20	100	42	14,3	E	328143R
M328.0020.02E	20	130	60	14,3	E	328143R
M328.0020.03E	20	160	85	14,3	E	328143R

w, Ds, tmax siehe Schneidplatte
w, Ds, tmax see inserts

Ersatzteile

Spare Parts

Fräuserschaft Milling shank	Spannschraube Clamping Screw	TORX PLUS®-Schlüssel TORX PLUS® Wrench
M328...	5.14T20P	T20PQ

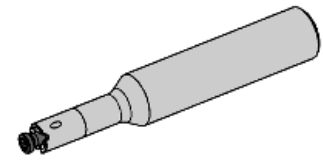
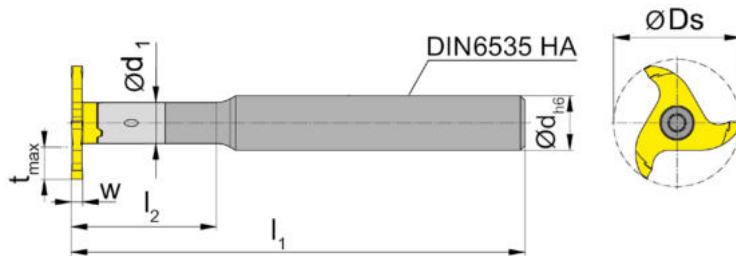
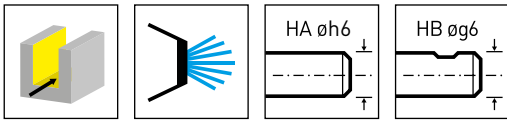

Bestellnummer Part number	d	l ₁	l ₂	d ₁	Form	HWS
M328.0909.01A	9	114,3	-	9	A	328114R
M328.0912.01A	12	100	32	9	A	328114R
M328.0912.01B	12	100	32	9	B	328114R

w, Ds, tmax siehe Schneidplatte
w, Ds, tmax see inserts

Halter M328.0909.01A = ohne Kühlmittelzufuhr!
Toolholder M328.0909.01A = no through coolant supply!

Ersatzteile
Spare Parts

Frälerschaft Milling shank	Spannschraube Clamping Screw	TORX PLUS®-Schlüssel TORX PLUS® Wrench
M328...	5.14T20P	T20PQ

B

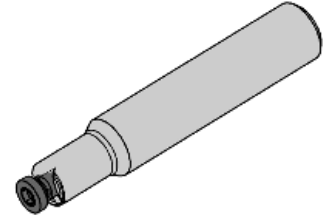
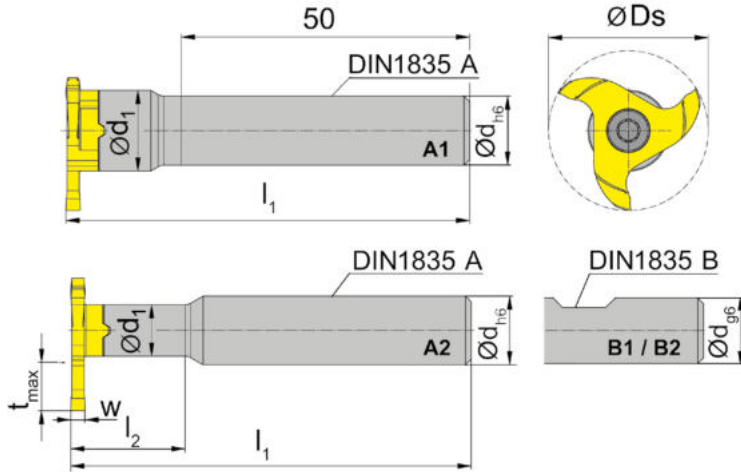
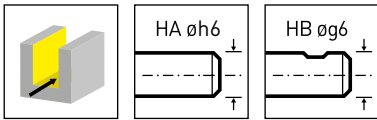

Bestellnummer Part number	d	l ₁	l ₂	d ₁	Form	HWS
M328.ST12.01A	12	70	-	14	A1	328143R
M328.ST13.01A	13	70	-	14	A1	328143R
M328.ST12.2.01A	12	70	20	9	A2	328114R
M328.ST16.01A	16	90	36	14	A2	328143R
M328.ST20.01A	20	100	36	14	A2	328143R
M328.ST12.01B	12	70	-	14	B1	328143R
M328.ST12.2.01B	12	70	20	9	B2	328114R
M328.ST16.01B	16	90	36	14	B2	328143R
M328.ST20.01B	20	100	36	14	B2	328143R

w, Ds, tmax siehe Schneidplatte
w, Ds, tmax see inserts

Ersatzteile

Spare Parts

Frälerschaft Milling shank	Spannschraube Clamping Screw	TORX PLUS®-Schlüssel TORX PLUS® Wrench
M328...	5.14T20P	T20PQ

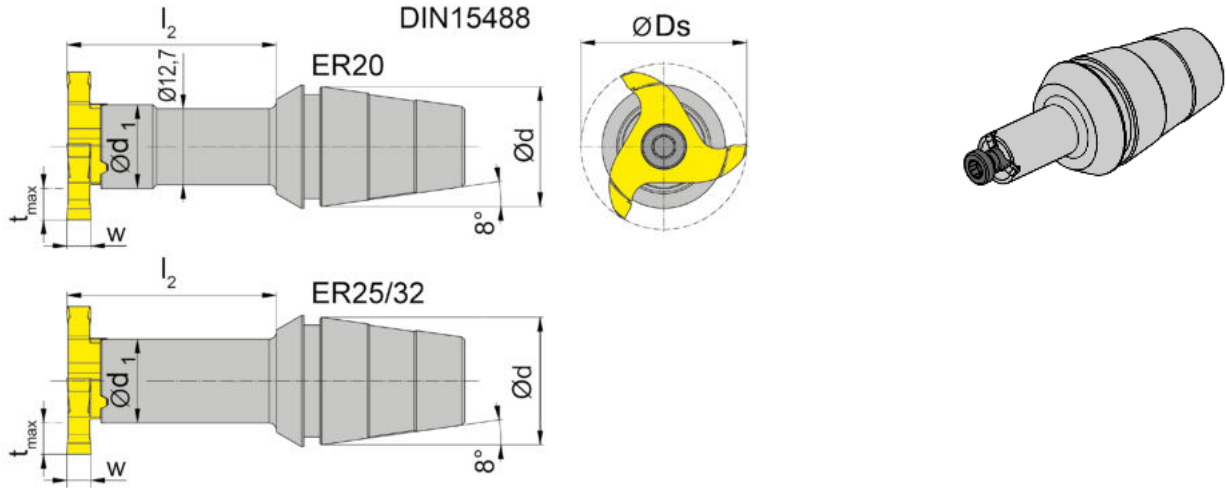
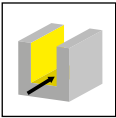

Bestellnummer Part number	d	l ₂	d ₁	Spannmutter Clamping nut	HWS
M328.ER20.02	20	35	14	ER20.6499/ERM20.6499	328114R
M328.ER25.02	25	35	14	ER25.6499	328114R
M328.ER32.02	32	35	14	ER32.6499	328114R

w, Ds, tmax siehe Schneidplatte
w, Ds, tmax see inserts

Spannmutter ist nicht im Lieferumfang enthalten - bitte separat bestellen!
Clamping nut is not combined with milling shank - separate order required!

Ersatzteile
Spare Parts

Frälerschaft Milling shank	Spannschraube Clamping Screw	TORX PLUS®-Schlüssel TORX PLUS® Wrench
M328...	5.14T20P	T20PQ

B

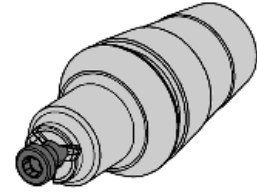
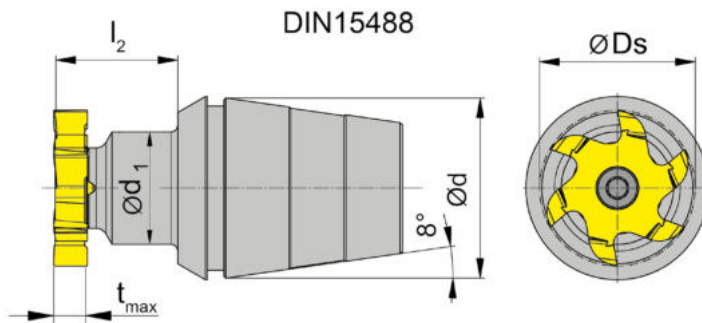
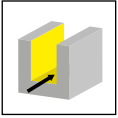

Bestellnummer Part number	d	l ₂	d ₁	Spannmutter Clamping nut	HWS
M328.ER25.16.01	25	21,7	15	ER25.6499	328114R
M328.ER32.16.01	32	21,7	20	ER32.6499	328114R

tmax und Ds siehe SP
tmax and Ds see inserts

Spannmutter ist nicht im Lieferumfang enthalten - bitte separat bestellen!
Clamping nut is not combined with milling shank - separate order required!

Ersatzteile

Spare Parts

Frälerschaft Milling shank	Spannschraube Clamping Screw	TORX PLUS®-Schlüssel TORX PLUS® Wrench
M328...	5.14T20P	T20PQ

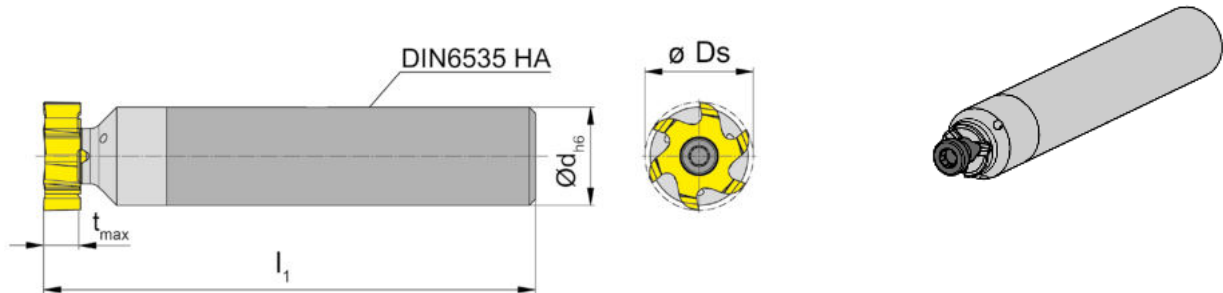
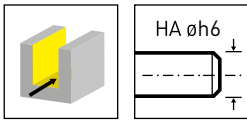

Bestellnummer Part number	d	l_1	Form	HWS
M328.0016.D.00A	16	80	A	328143R
M328.0020.D.00A	20	80	A	328143R

tmax und Ds siehe SP
tmax and Ds see inserts

Ersatzteile
Spare Parts

Fräserschaft Milling shank	Spannschraube Clamping Screw	TORX PLUS®-Schlüssel TORX PLUS® Wrench
M328...	5.14T20P	T20PQ

B

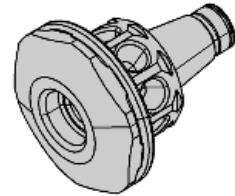
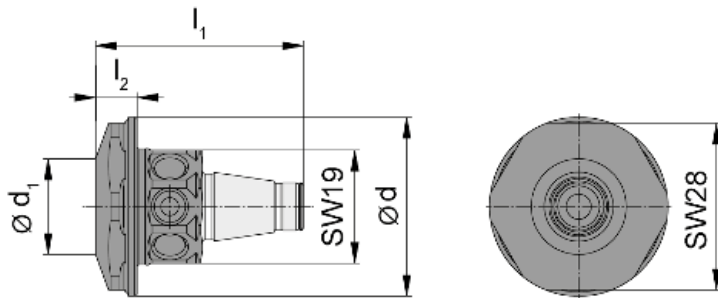

Bestellnummer Part number	l_1	l_2	d_1	d
WFB.2012.M081.01	35	7	16	30

für Einschraubfräser
for Screw-in cutter

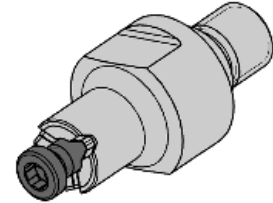
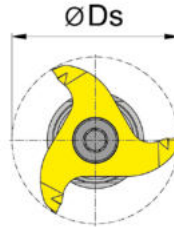
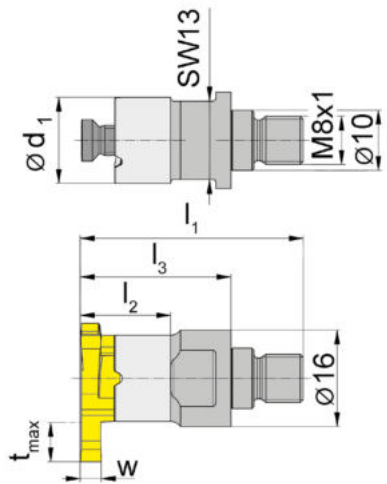
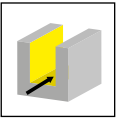

Bestellnummer Part number	l_1	l_2	l_3	d_1	SW	HWS
M328.M081.01	37	15	25	14,3	13	328143R

w, Ds, tmax siehe Schneidplatte
w, Ds, tmax see inserts

Ersatzteile
Spare Parts

Einschraubfräser Screw-in cutter	Spannschraube Clamping Screw	TORX PLUS®-Schlüssel TORX PLUS® Wrench
M328.M081.01	5.14T20P	T20PQ

B



Abbildung = rechtsschneidend
Picture = right hand cutting version

▲ ab Lager
on stock

HM-Sorten
Carbide grades
Δ 4 Wochen
4 weeks

Bestellnummer Part number	Ds	w	s	r	t _{max}	Z	HIS	HM-Sorten Carbide grades	
								AS45	TN35
325.0350.52	24,8	3,5	5,7	0,2	5	3	328143R	▲	▲
								P	● ●
								M	● ●
								K	● ●
								N	○ ●
								S	● ●
								H	- -

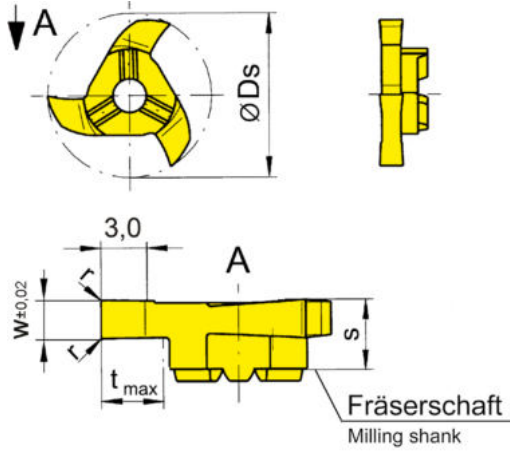
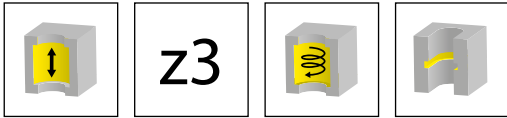
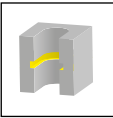

z3

B



Abbildung = rechtsschneidend
Picture = right hand cutting version

▲ ab Lager
on stock

HM-Sorten
Carbide grades
Δ 4 Wochen
4 weeks

Bestellnummer Part number	Ds	w	s	r	t _{max}	Z	HIS	AS45	TN35
328.0200.00	27,7	2	5,7	0,2	6,5	3	328143R	▲	▲
328.0250.00	27,7	2,5	5,7	0,2	6,5	3	328143R	▲	▲
328.0300.00	27,7	3	5,7	0,2	6,5	3	328143R	▲	▲
328.0350.00	27,7	3,5	5,7	0,2	6,5	3	328143R	▲	▲
328.0400.00	27,7	4	5,7	0,2	6,5	3	328143R	▲	▲
328.0500.00	27,7	5	5,7	0,2	6,5	3	328143R	▲	▲
328.0600.00	27,7	6	7	0,2	6,5	3	328143R	▲	▲
328.1000.00	27,7	10	10	0,2	6,5	3	328143R	▲	▲

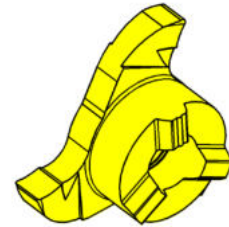
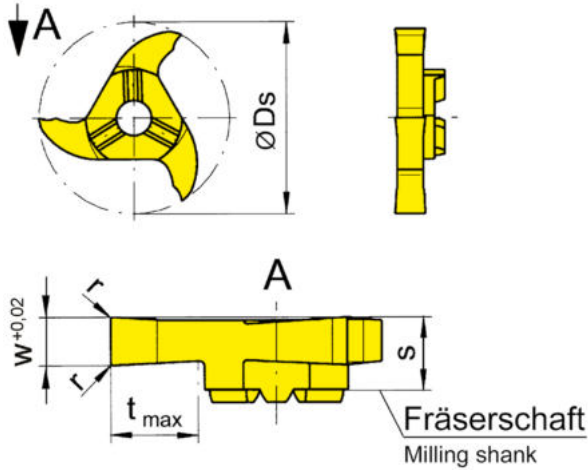
Schneidplatte **328.1000.00** mit Schnittaufteilung (Z=1) und Schneidplatte **328.0600.00** mit Spanteilern (Z=3)!
Insert 328.1000.00 with staggered tooth (Z=1) and insert 328.0600.00 with chip divider (Z=3)!

Für Schneidplatte w = 2 - 6 mm Schraube 4.14T20P verwenden
Für Schneidplatte w = 7 - 8 mm Schraube 5.17T20P verwenden
Für Schneidplatte w = 10 mm Schraube 5.13T20P verwenden
For Insert w = 2 - 6 mm use screw 4.14T20P
For Insert w = 7 - 8 mm use screw 5.17T20P
For Insert w = 10 mm use screw 5.13T20P

P	●	●
M	●	●
K	●	●
N	○	●
S	●	●
H	-	-

B



Abbildung = linksschneidend
Picture = left hand cutting version

HM-Sorten
Carbide grades
▲ ab Lager
on stock
Δ 4 Wochen
4 weeks

Bestellnummer Part number	Ds	Nw	w	t ₁	s	s ₁	r	t _{max}	Z	HIS	AS45
328.1307.30	27,7	1,3	1,41	0,65	5,95	4,9	-	0,7	3	328143R	▲
328.1812.35	27,7	1,85	1,96	1,21	5,95	5,1	0,2	1,25	3	328143R	▲
											P ●
											M ●
											K ●
											N ○
											S ●
											H -

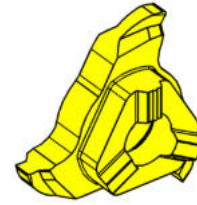
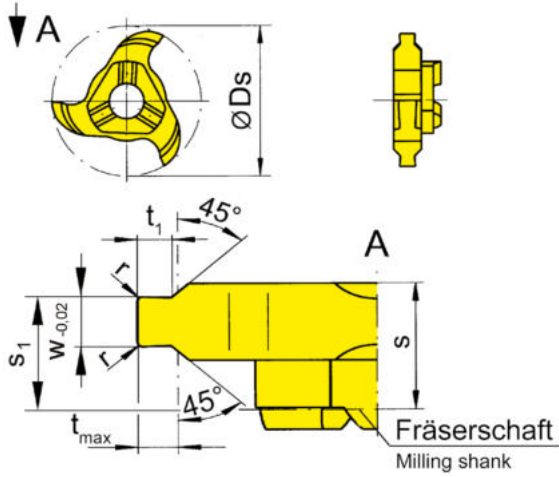
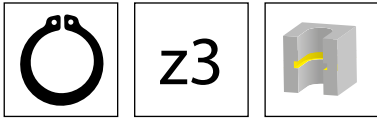

Abbildung = rechtsschneidend
Picture = right hand cutting version

▲ ab Lager
on stock

HM-Sorten
Carbide grades
Δ 4 Wochen
4 weeks

Bestellnummer Part number	Ds	w	s	r	t _{max}	Z	HIS	TI25
328.0250.40	27,7	2,5	5,7	0,2	6,5	3	328143R	▲
328.0300.40	27,7	3	5,7	0,2	6,5	3	328143R	▲
328.0350.40	27,7	3,5	5,7	0,2	6,5	3	328143R	▲
328.0400.40	27,7	4	5,7	0,2	6,5	3	328143R	▲

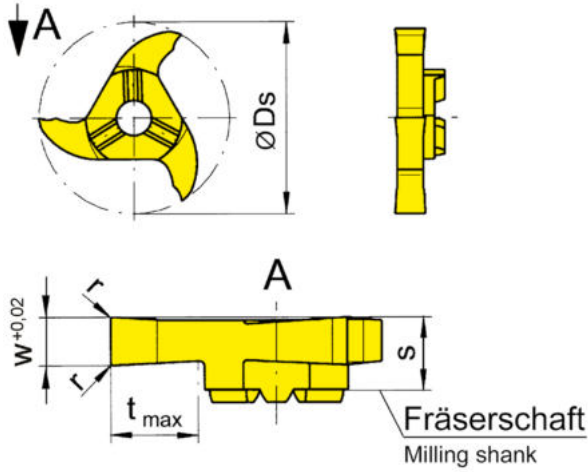
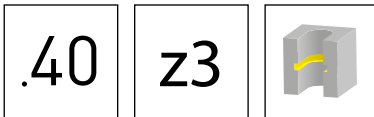
Bei Reduzierung der Frästiefe t_{max} ist eine Schneidbreite w bis 0,5 mm auf Anfrage möglich.
Inserts for widths of groove t_{max} down to 0,5 mm can be delivered with reduced depth upon request.

P	-
M	-
K	-
N	●
S	-
H	-

B

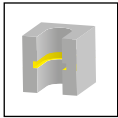

z3



Abbildung = rechtsschneidend
Picture = right hand cutting version

▲ ab Lager
on stock

HM-Sorten
Carbide grades
Δ 4 Wochen
4 weeks

Bestellnummer Part number	Ds	w	s	t _{max}	Z	HIS	HM-Sorten Carbide grades	
							Tl25	TN35
328.0082.1.00	27,7	0,82	5,7	5	3	328143R	▲	▲
							P	●
							M	●
							K	●
							N	●
							S	●
							H	-

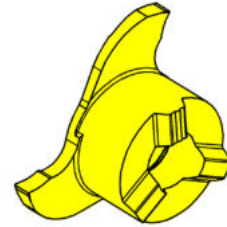
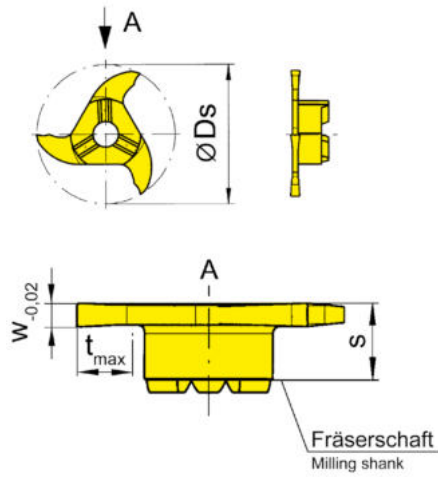
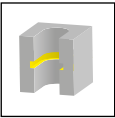

z3

B



Abbildung = rechtsschneidend
Picture = right hand cutting version

▲ ab Lager
on stock

HM-Sorten
Carbide grades

△ 4 Wochen
4 weeks

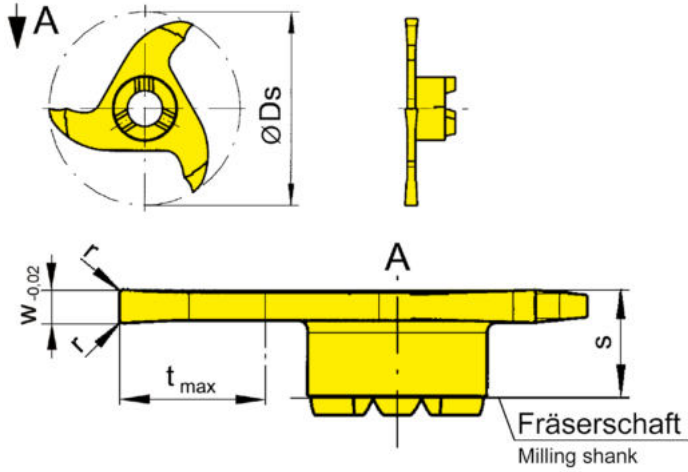
Bestellnummer Part number	Ds	w	s	r	t _{max}	Z	HIS	AS45	TI25	TN35
328.0110.2.00	28	1,1	5,7	0,2	9,3	3	328114R		▲	▲
328.0120.2.00	28	1,2	5,7	0,2	9,3	3	328114R		▲	▲
328.0132.2.00	28	1,32	5,7	0,15	9,3	3	328114R		▲	▲
328.0150.2.00	28	1,5	5,7	0,2	9,3	3	328114R	▲	▲	▲
328.0160.2.00	28	1,6	5,7	0,2	9,3	3	328114R	▲	▲	▲
328.0200.2.00	28	2	5,7	0,2	9,3	3	328114R	▲	▲	▲
328.0250.2.00	28	2,5	5,7	0,2	9,3	3	328114R	▲	▲	▲
P	●	●	●							
M	●	●	●							
K	●	●	●							
N	○	●	●							
S	●	●	●							
H	-	-	-							

B



Abbildung = rechtsschneidend
Picture = right hand cutting version

HM-Sorten
Carbide grades
▲ ab Lager
on stock
Δ 4 Wochen
4 weeks

Bestellnummer Part number	Ds	E	s	w	t _{max}	Z	HIS	TA45
328.4545.35.00	27,7	3,8	10,2	2,6	3,5	3	328143R	▲

Für die Schneidplatte **328.4545.35.00** bitte nur die längere Schraube 5.13T20P verwenden.
For insert 328.4545.35.00 please use only the longer screw 5.13T20P.

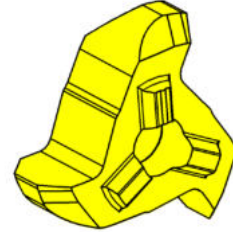
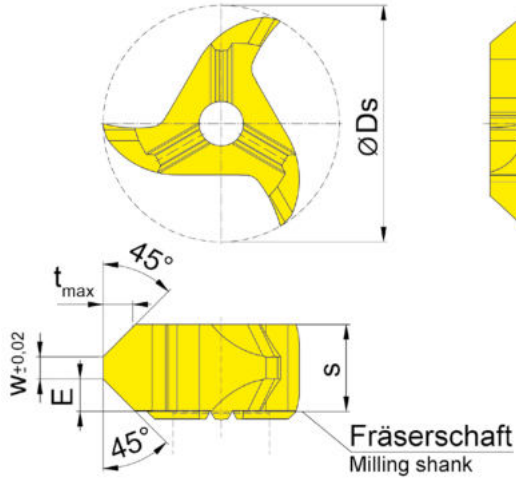
P	●
M	●
K	●
N	●
S	●
H	-



Abbildung = rechtsschneidend
Picture = right hand cutting version

▲ ab Lager
on stock

△ 4 Wochen
4 weeks

HM-Sorten
Carbide grades

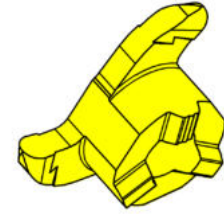
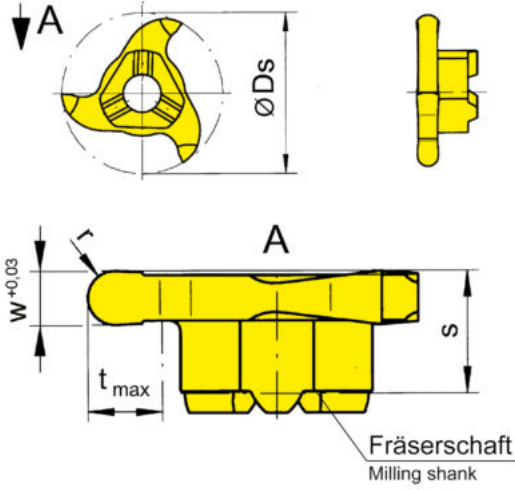
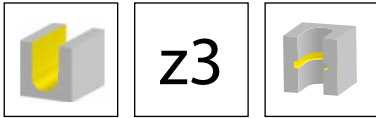
Bestellnummer Part number	D_s	w	s	r	t_{max}	Z	HIS	AS/45
328.0010.20	27,7	2	5,7	1	6,5	3	328143R	▲
328.0014.28	27,7	2,8	5,7	1,4	6,5	3	328143R	▲
328.0015.30	27,7	3	5,7	1,5	6,5	3	328143R	▲
328.0020.40	27,7	4	5,7	2	6,5	3	328143R	▲
								P ●
								M ●
								K ●
								N ○
								S ●
								H -

B



Abbildung = rechtsschneidend
Picture = right hand cutting version

HM-Sorten
Carbide grades
▲ ab Lager
on stock
△ 4 Wochen
4 weeks

Bestellnummer Part number	Ds	w	s	r	t _{max}	Z	HIS	AS/45
628.0010.20	27,7	2	6,1	1	6,5	6	328143R	▲
628.0015.30	27,7	3	6,1	1,5	6,5	6	328143R	▲
628.0020.40	27,7	4	6,1	2	6,5	6	328143R	▲
								P ●
								M ●
								K ●
								N ○
								S ●
								H -

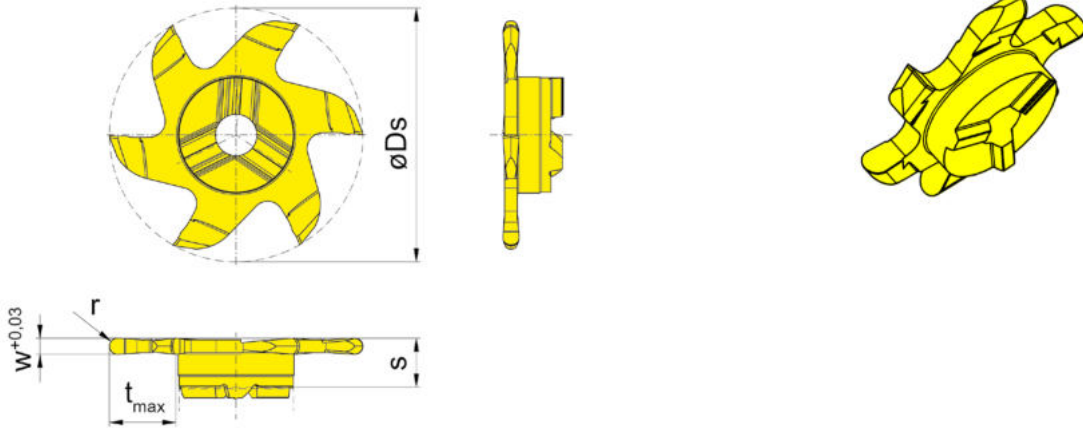

z6

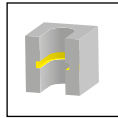

B



Abbildung = rechtsschneidend
Picture = right hand cutting version

▲ ab Lager
on stock

HM-Sorten
Carbide grades

Δ 4 Wochen
4 weeks

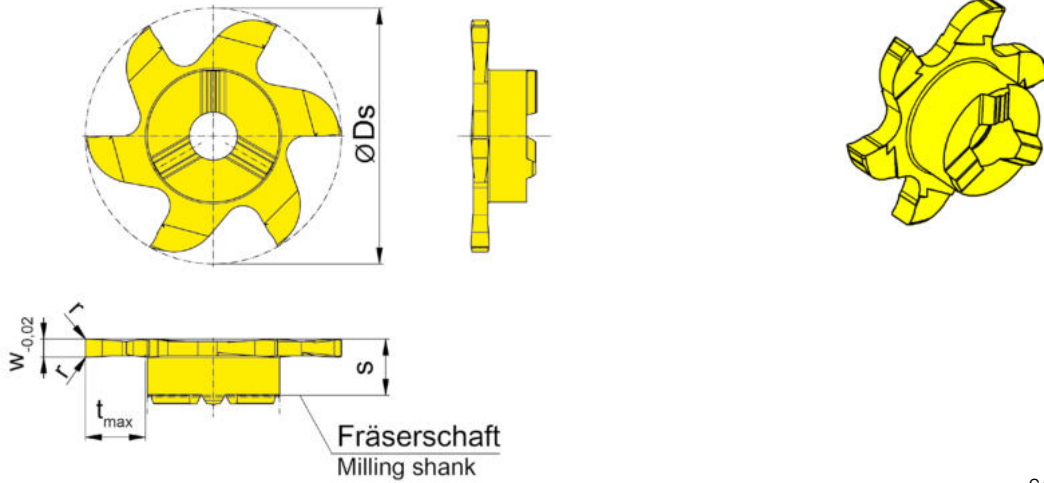
Bestellnummer Part number	Ds	Nw	w	s	r	t _{max}	Z	HIS		AN25	AS45	RC25	TI25
628.0080.00	27,7	0,8	0,8	6,1	-	6,5	6	328143R		Δ		▲	
628.0130.00	27,7	1,3	1,41	6,1	-	6,5	6	328143R			▲		▲
628.0160.00	27,7	1,6	1,71	6,1	-	6,5	6	328143R			▲		▲
628.0185.00	27,7	1,85	1,96	6,1	0,2	6,5	6	328143R			▲		▲
628.0215.00	27,7	2,15	2,26	6,1	0,2	6,5	6	328143R			▲		▲
628.0265.00	27,7	2,65	2,76	6,1	0,2	6,5	6	328143R			▲		▲
									P	●	●	●	●
									M	○	●	●	●
									K	-	●	●	●
									N	-	○	-	●
									S	-	●	-	●
									H	-	-	-	-

B

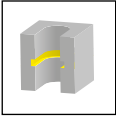

z6



Abbildung = rechtsschneidend
Picture = right hand cutting version

▲ ab Lager
on stock

HM-Sorten
Carbide grades
Δ 4 Wochen
4 weeks

Bestellnummer Part number	Ds	w	s	r	t _{max}	Z	HIS	AS45	TH35	TI25
628.0150.00	27,7	1,5	6,1	-	6,5	6	328143R	▲		
628.0200.00	27,7	2	6,1	0,2	6,5	6	328143R	▲		
628.0250.00	27,7	2,5	6,1	0,2	6,5	6	328143R	▲		▲
628.0300.00	27,7	3	6,1	0,2	6,5	6	328143R	▲		▲
628.0350.00	27,7	3,5	6,1	0,2	6,5	6	328143R	▲		▲
628.0400.00	27,7	4	6,1	0,2	6,5	6	328143R	▲	▲	▲
								P ●	●	●
								M ●	●	●
								K ●	●	●
								N ○	●	●
								S ●	●	●
								H -	-	-

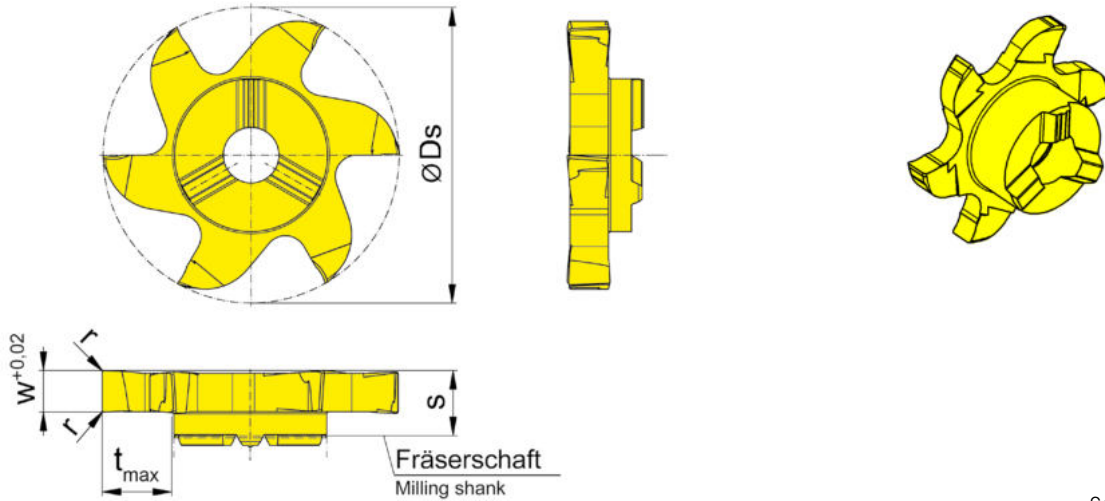
Bei Reduzierung der Frästiefe t_{max} ist eine Schneidbreite w bis 0,5 mm auf Anfrage möglich.
Inserts for widths of groove t_{max} down to 0,5 mm can be delivered with reduced depth upon request.

Schneidplatte 628.0400.00

nur in Verbindung mit Fräuserschaftabmessung l₂= max. 42 mm

Insert 628.0400.00

only with toolholder dimension l₂ = max. 42 mm

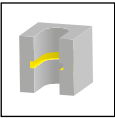

z6

B



Abbildung = rechtsschneidend
Picture = right hand cutting version

HM-Sorten
Carbide grades
▲ ab Lager
on stock
Δ 4 Wochen
4 weeks

Bestellnummer Part number	Ds	w	s	r	t _{max}	Z	HIS	AS45
628.0300.04	27,7	3	6,1	0,4	6,5	6	328143R	▲
628.0300.08	27,7	3	6,1	0,8	6,5	6	328143R	▲
628.0400.04	27,7	4	6,1	0,4	6,5	6	328143R	▲
628.0400.08	27,7	4	6,1	0,8	6,5	6	328143R	▲
								P ●
								M ●
								K ●
								N ○
								S ●
								H -

B

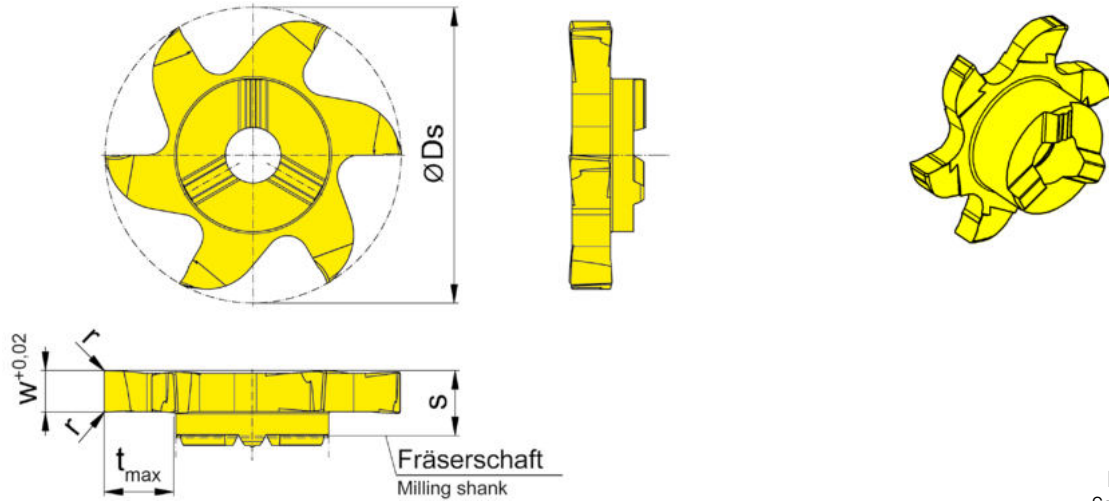

Abbildung = rechtsschneidend
Picture = right hand cutting version

▲ ab Lager
on stock

HM-Sorten
Carbide grades
Δ 4 Wochen
4 weeks

Bestellnummer Part number	Ds	w	s	r	t _{max}	Z	HIS	AS45	TI25
628.0100.2.00	28	1	6,1	-	9,3	6	328114R		▲
628.0120.2.00	28	1,2	6,1	-	9,3	6	328114R		▲
628.0150.2.00	28	1,5	6,1	-	9,3	6	328114R	▲	▲
628.0160.2.00	28	1,6	6,1	-	9,3	6	328114R	▲	▲
628.0200.2.00	28	2	6,1	0,2	9,3	6	328114R	▲	▲
628.0240.2.00	28	2,4	6,1	0,2	9,3	6	328114R	Δ	▲
628.0250.2.00	28	2,5	6,1	0,2	9,3	6	328114R	▲	▲
								P	● ●
								M	● ●
								K	● ●
								N	○ ●
								S	● ●
								H	- -

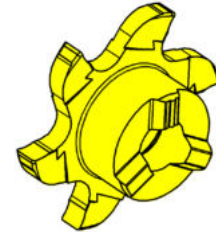
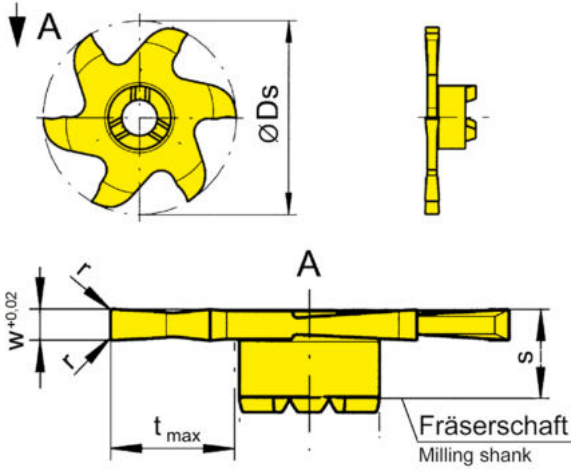
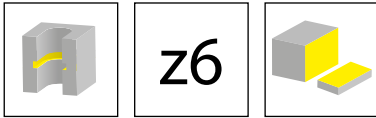

Abbildung = rechtsschneidend
Picture = right hand cutting version

▲ ab Lager
on stock

HM-Sorten
Carbide grades
Δ 4 Wochen
4 weeks

Bestellnummer Part number	Ds	Z	r	t _{max}	s	HIS	AS45	TF45	TI25
628.PL61.62	27,7	6	0,2	5,7	6,1	328143R	▲	▲	▲
Schrägverzahnung Helical teeth							P ●	●	●
							M ●	●	●
							K ●	●	●
							N ○	●	●
							S ●	●	●
							H -	-	-

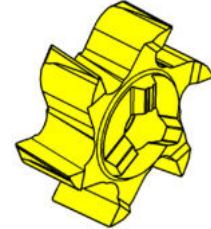
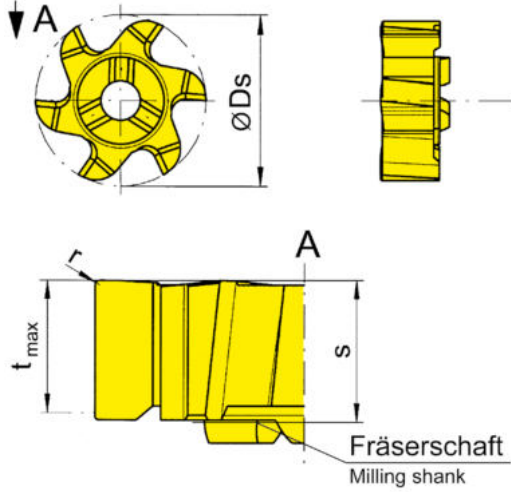
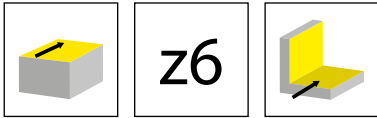
B



Abbildung = rechtsschneidend
Picture = right hand cutting version

▲ ab Lager
on stock

HM-Sorten
Carbide grades

Δ 4 Wochen
4 weeks

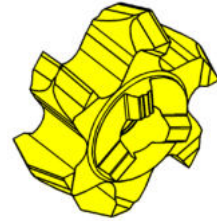
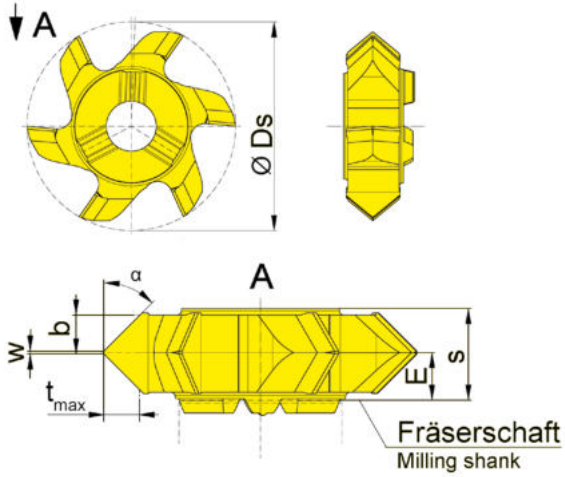
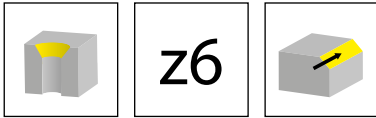
Bestellnummer Part number	Ds	E	s	w	α	b	t_{max}	Z	HIS	AS45	TA45
628.1515.20	27,7	3,2	6,3	0,2	15°	2,8	0,75	6	328143R	▲	
628.2020.20	27,7	3,2	6,3	0,2	20°	2,8	1	6	328143R	▲	
628.3030.20	27,7	3,2	6,3	0,2	30°	2,8	1,6	6	328143R	▲	▲
628.4545.20	27,7	3,2	6,3	0,2	45°	2,8	2,8	6	328143R	▲	▲
										P	● ●
										M	● ●
										K	● ●
										N	○ ●
										S	● ●
										H	- -

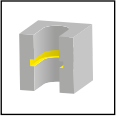

z9

B



Abbildung = rechtsschneidend
Picture = right hand cutting version

▲ ab Lager
on stock

HM-Sorten
Carbide grades
Δ 4 Wochen
4 weeks

Bestellnummer Part number	Ds	w	s	b x 45°	r	t _{max}	Z	HIS	EG55	IG65
928.0150.00	27,7	1,5	6,1	0,05	-	6,5	9	328143R	▲	Δ
928.0200.00	27,7	2	6,1	-	0,2	6,5	9	328143R	▲	Δ
928.0250.00	27,7	2,5	6,1	-	0,2	6,5	9	328143R	▲	Δ
928.0300.00	27,7	3	6,1	-	0,2	6,5	9	328143R	▲	Δ
									P ● ●	
									M ○ ●	
									K ○ -	
									N - -	
									S - ○	
									H - -	

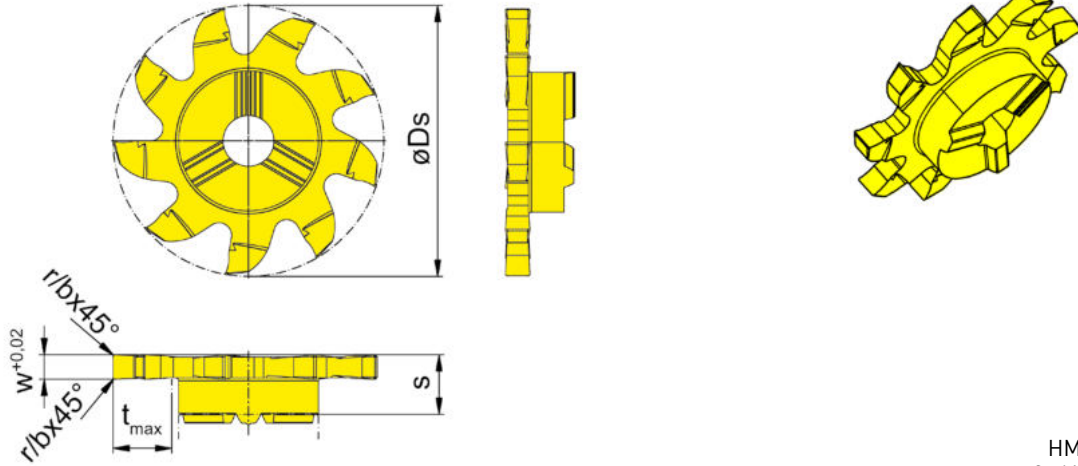
Nutfräsen (zirkular)

Groove Milling by circular interpolation

B

Frälerschaft
Milling shank
M332/M332.ST/M332.ER

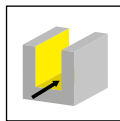

Seite/Page
178-181

Grundaufnahme
Basic Holder
WFB

Seite/Page
182

Einschraubfräser
Screw-in cutter
M332.M

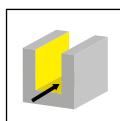

Seite/Page
183

Schneidplatte
Insert
332/632/636/932
939

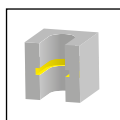

Seite/Page
184-185, 189-
190, 193-197

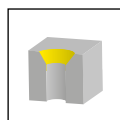

Seite/Page
186



Seite/Page
187-188

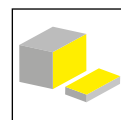

Seite/Page
191-192, 198

M332



**Fräser mit wechselbarer
Schneidplatte**

ab Bohrung \varnothing 32 mm

**Milling shank with
exchangeable insert**

from bore \varnothing 32 mm

B



Abbildung = rechtsschneidend
Picture = right hand cutting version

Bestellnummer Part number	d	l ₁	l ₂	d ₁	Form	HWS
M332.0016.01A	16	100	42	14,3	A	332143R
M332.0016.02A	16	130	60	14,3	A	332143R
M332.0016.03A	16	160	85	14,3	A	332143R
M332.0020.01A	20	100	42	14,3	A	332143R
M332.0020.02A	20	130	60	14,3	A	332143R
M332.0020.03A	20	160	85	14,3	A	332143R
M332.0016.01B	16	100	42	14,3	B	332143R
M332.0016.02B	16	130	60	14,3	B	332143R
M332.0016.03B	16	160	85	14,3	B	332143R
M332.0020.01B	20	100	42	14,3	B	332143R
M332.0020.02B	20	130	60	14,3	B	332143R
M332.0020.03B	20	160	85	14,3	B	332143R

w, Ds, tmax siehe Schneidplatte
w, Ds, tmax see inserts

Ersatzteile

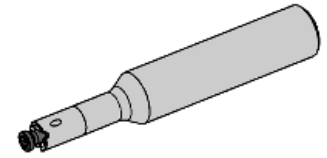
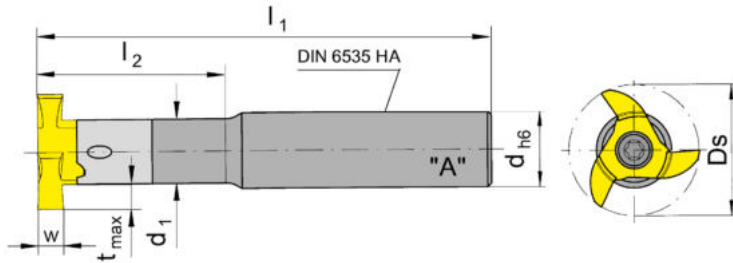
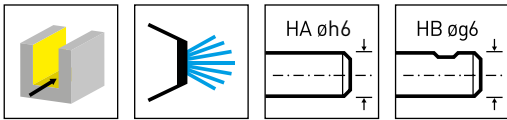
Spare Parts

Fräserschaft Milling shank	Spannschraube Clamping Screw	TORX PLUS®-Schlüssel TORX PLUS® Wrench
M332...	5.17T20P	T20PQ



Abbildung = rechtsschneidend
Picture = right hand cutting version

Bestellnummer Part number	d	l ₁	l ₂	d ₁	Form	HWS
M332.0012.2.01A	12	100	32	11	A	332110R
M332.0012.3.00A	12	100	-	12	A	332120R
M332.0016.2.02A	16	130	68	11	A	332110R
M332.0016.2.01A	16	100	32	11	A	332110R

w, Ds, tmax siehe Schneidplatte
w, Ds, tmax see inserts

Ersatzteile
Spare Parts

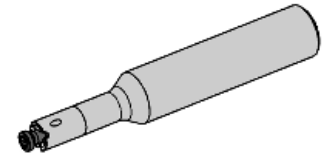
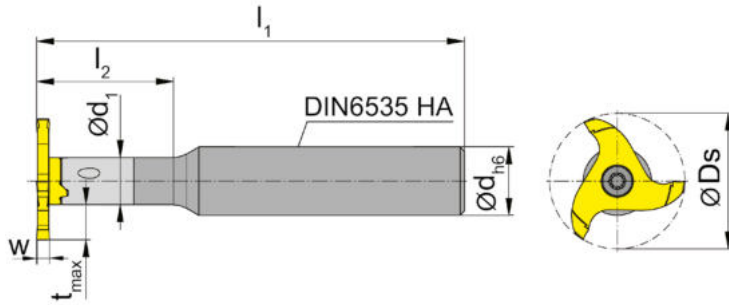
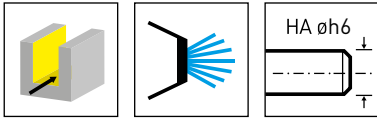
Fräserschaft Milling shank	Spannschraube Clamping Screw	TORX PLUS®-Schlüssel TORX PLUS® Wrench
M332...	5.17T20P	T20PQ

B



Abbildung = rechtsschneidend
Picture = right hand cutting version

Bestellnummer Part number	d	l_1	l_2	d_1	Form	HWS
M332.ST10.2.01A	10	70	25	11	A	332110R
M332.ST12.2.01A	12	70	25	11	A	332110R
M332.ST13.2.01A	13	70	25	11	A	332110R
M332.ST16.01A	16	90	36	14,3	A	332143R
M332.ST20.01A	20	100	36	14,3	A	332143R
M332.ST12.2.01B	12	70	25	11	B	332110R
M332.ST16.01B	16	90	36	14,3	B	332143R

w, D_s , t_{max} siehe Schneidplatte
w, D_s , t_{max} see inserts

Frälerschäfte **M332.ST12.2.01A**, **M332.ST12.2.01B** und **M332.ST13.2.01A** sind für Schneidplatten mit erhöhter Frästiefe!
Milling shanks M332.ST12.2.01A, M332.ST12.2.01B and M332.ST13.2.01A are usable for inserts with increased milling depth!

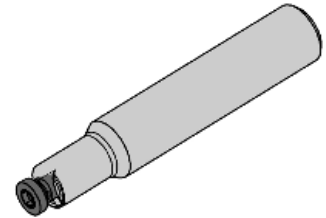
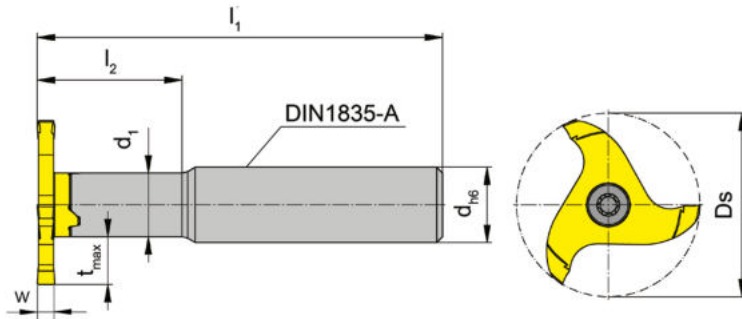
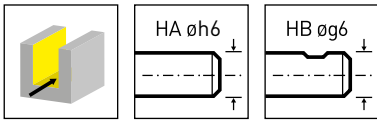
Ersatzteile
Spare Parts

Frälerschaft Milling shank	Spannschraube Clamping Screw	TORX PLUS®-Schlüssel TORX PLUS® Wrench
M332...	5.17T20P	T20PQ

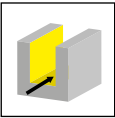

B



Abbildung = rechtsschneidend
Picture = right hand cutting version

Bestellnummer Part number	d	l ₂	d ₁	Spannmutter Clamping nut	HWS
M332.ER20.02	20	35	14,3	ER20.6499/ERM20.6499	332143R

w, Ds, tmax siehe Schneidplatte
w, Ds, tmax see inserts

Spannmutter ist nicht im Lieferumfang enthalten - bitte separat bestellen!
Clamping nut is not combined with milling shank - separate order required!

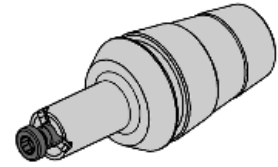
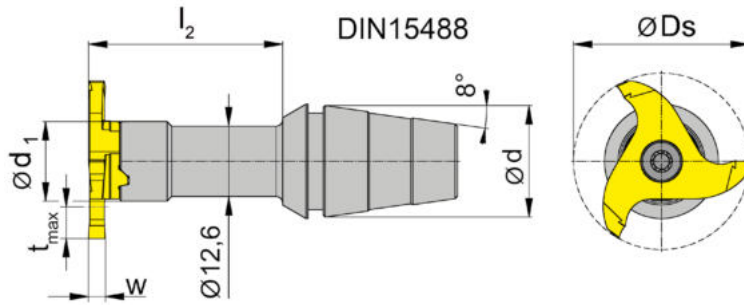
Ersatzteile
Spare Parts

Frälerschaft Milling shank	Spannschraube Clamping Screw	TORX PLUS®-Schlüssel TORX PLUS® Wrench
M332.ER20.02	5.17T20P	T20PQ

B

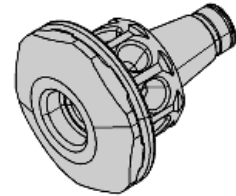
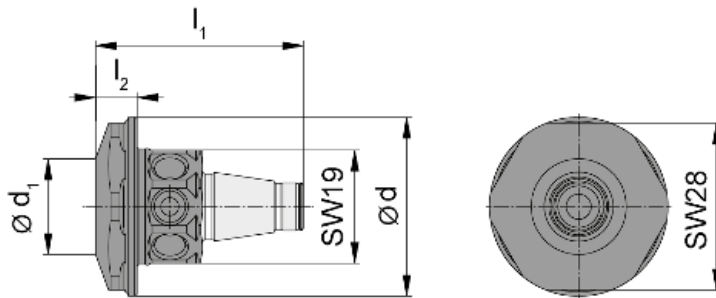

Bestellnummer Part number	l_1	l_2	d_1	d
WFB.2012.M081.01	35	7	16	30

für Einschraubfräser
for Screw-in cutter

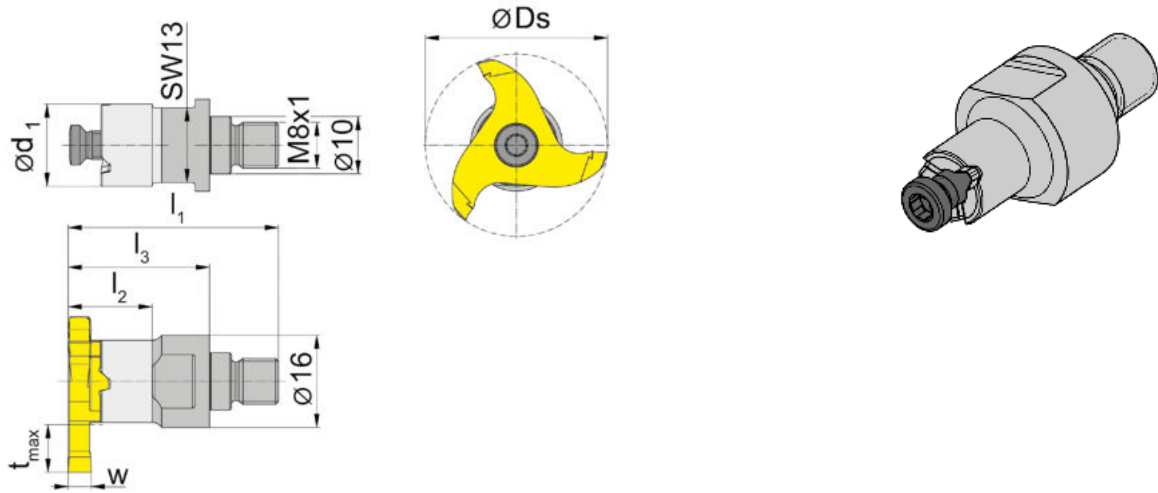
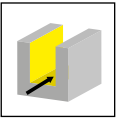

Bestellnummer Part number	l_1	l_2	l_3	d_1	SW	HWS	HMS
M332.M081.01	37	15	25	14,3	13	332143R	8001

w, D_s, t_{max} siehe Schneidplatte
w, D_s, t_{max} see inserts

Ersatzteile
Spare Parts

Einschraubfräser Screw-in cutter	Spannschraube Clamping Screw	TORX PLUS®-Schlüssel TORX PLUS® Wrench
M332.M081.01	5.17T20P	T20PQ

B

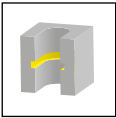

z3



Abbildung = rechtsschneidend
Picture = right hand cutting version

▲ ab Lager
on stock

HM-Sorten
Carbide grades

Δ 4 Wochen
4 weeks

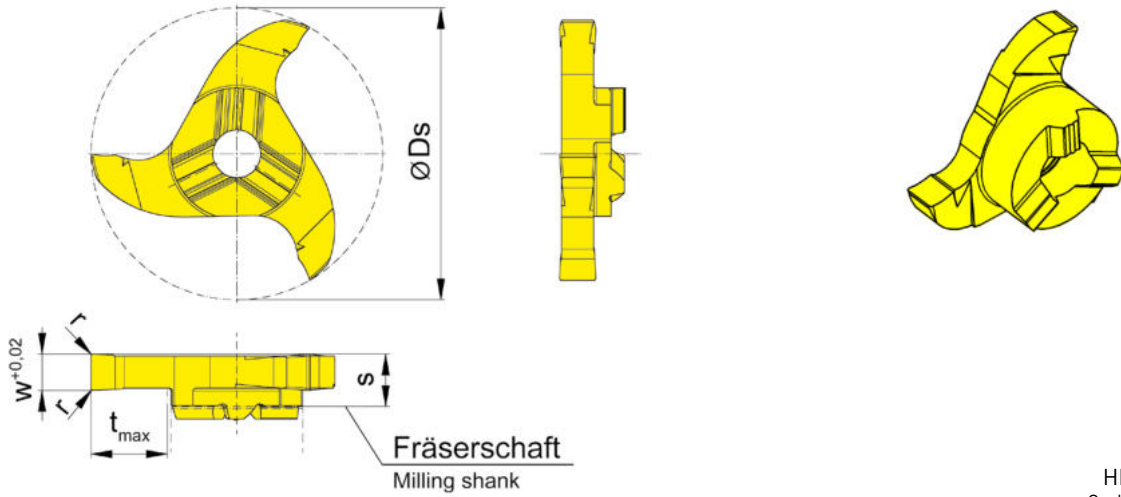
Bestellnummer Part number	Ds	w	s	r	t _{max}	Z	HIS	AS45	TI25
332.0200.00	31,7	2	5,7	0,2	8,3	3	332143R	Δ	▲
332.0250.00	31,7	2,5	5,7	0,2	8,3	3	332143R	Δ	▲
332.0300.00	31,7	3	5,7	0,2	8,3	3	332143R	▲	▲
332.0350.00	31,7	3,5	5,7	0,2	8,3	3	332143R	▲	▲
332.0400.00	31,7	4	5,7	0,2	8,3	3	332143R	▲	▲
								P ● ●	
								M ● ●	
								K ● ●	
								N ○ ●	
								S ● ●	
								H - -	

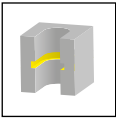

z3



Abbildung = rechtsschneidend
Picture = right hand cutting version

▲ ab Lager
on stock

HM-Sorten
Carbide grades
Δ 4 Wochen
4 weeks

Bestellnummer Part number	D_s	w	s	r	t_{max}	Z	HIS	AS45	TI25
332.0150.2.00	31,7	1,5	5,7	0,2	10	3	332110R	Δ	▲
332.0160.2.00	31,7	1,6	5,7	0,2	10	3	332110R	Δ	▲
332.0200.2.00	31,7	2	5,7	0,2	10	3	332110R	▲	▲
332.0250.2.00	31,7	2,5	5,7	0,2	10	3	332110R	▲	▲
332.0300.2.00	31,7	3	5,7	0,2	10	3	332110R	▲	▲
								P	●
								M	●
								K	●
								N	○
								S	●
								H	-

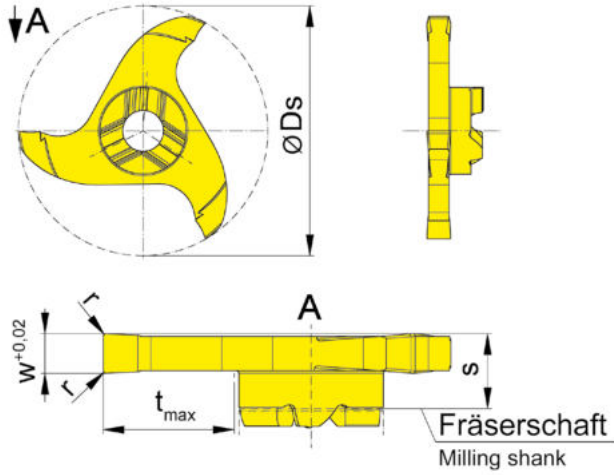
B



Abbildung = rechtsschneidend
Picture = right hand cutting version

HM-Sorten
Carbide grades
▲ ab Lager
on stock
Δ 4 Wochen
4 weeks

Bestellnummer Part number	Ds	E	s	w	t _{max}	Z	HIS	TA45
332.4545.35.00	31,7	4,25	10,6	2,6	3,5	3	332143R	▲
								P ●
								M ●
								K ●
								N ●
								S ●
								H -

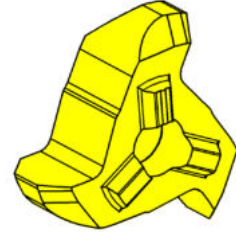
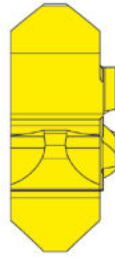
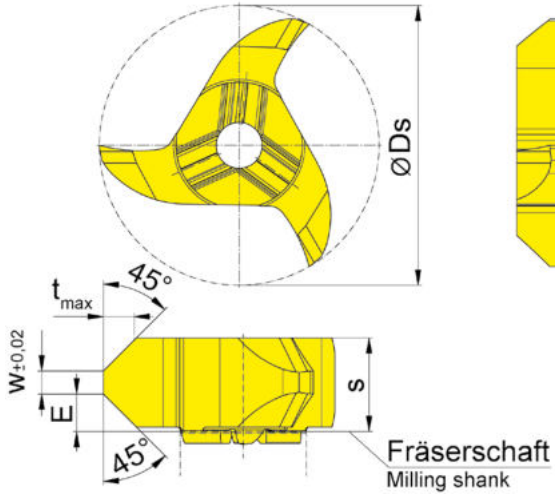

Abbildung = rechtsschneidend
Picture = right hand cutting version

▲ ab Lager
on stock

HM-Sorten
Carbide grades

Δ 4 Wochen
4 weeks

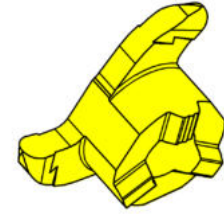
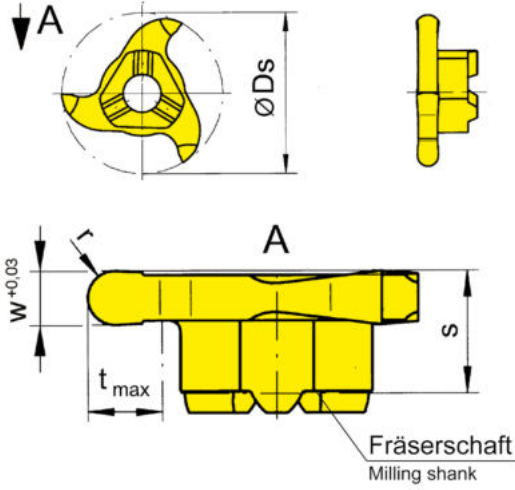
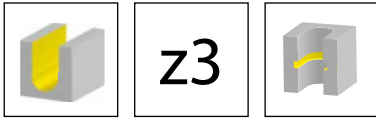
Bestellnummer Part number	Ds	w	s	r	t _{max}	Z	HIS	AS45
332.0010.20	31,7	2	5,7	1	8,3	3	332143R	▲
332.0015.30	31,7	3	5,7	1,5	8,3	3	332143R	▲
332.0020.40	31,7	4	5,7	2	8,3	3	332143R	▲
								P ●
								M ●
								K ●
								N ○
								S ●
								H -

B



z6



Abbildung = rechtsschneidend
Picture = right hand cutting version

HM-Sorten
Carbide grades
▲ ab Lager
on stock
△ 4 Wochen
4 weeks

Bestellnummer Part number	Ds	w	s	r	t _{max}	Z	HIS	AS/45
632.0010.20	31,7	2	6,1	1	8,3	6	332143R	▲
632.0015.30	31,7	3	6,1	1,5	8,3	6	332143R	▲
632.0020.40	31,7	4	6,1	2	8,3	6	332143R	▲
								P ●
								M ●
								K ●
								N ○
								S ●
								H -

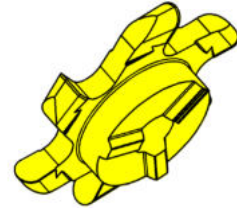
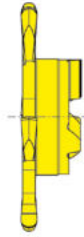
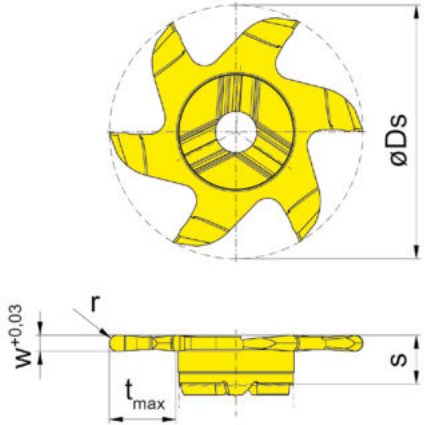
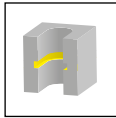
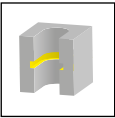

z6

B



Abbildung = rechtsschneidend
Picture = right hand cutting version

▲ ab Lager
on stock

HM-Sorten
Carbide grades
Δ 4 Wochen
4 weeks

Bestellnummer Part number	Ds	w	s	r	t _{max}	Z	HIS	AS45	TA45
632.0200.00	31,7	2	6,1	0,2	8,3	6	332143R	▲	▲
632.0250.00	31,7	2,5	6,1	0,2	8,3	6	332143R	▲	▲
632.0300.00	31,7	3	6,1	0,2	8,3	6	332143R	▲	▲
632.0400.00	31,7	4	6,1	0,2	8,3	6	332143R	▲	▲
								P	● ●
								M	● ●
								K	● ●
								N	○ ●
								S	● ●
								H	- -

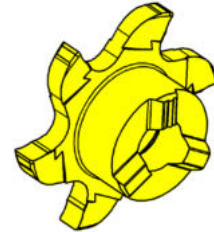
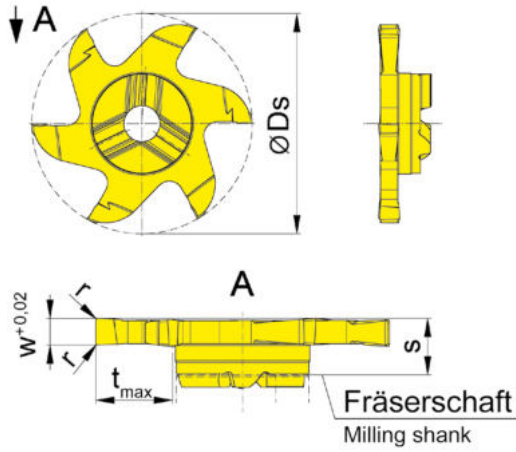
B

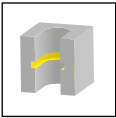

z6



Abbildung = rechtsschneidend
Picture = right hand cutting version

▲ ab Lager
on stock

HM-Sorten
Carbide grades
Δ 4 Wochen
4 weeks

Bestellnummer Part number	Ds	w	s	r	t _{max}	Z	HIS	AS45	TA45
632.0100.2.00	31,7	1	6,1	-	10	6	332110R	▲	
632.0120.2.00	31,7	1,2	6,1	0,1	10	6	332110R	▲	
632.0150.2.00	31,7	1,5	6,1	0,2	10	6	332110R	▲	▲
632.0160.2.00	31,7	1,6	6,1	0,2	10	6	332110R	▲	▲
632.0200.2.00	31,7	2	6,1	0,2	10	6	332110R	▲	▲
632.0250.2.00	31,7	2,5	6,1	0,2	10	6	332110R	Δ	▲
632.0300.2.00	31,7	3	6,1	0,2	10	6	332110R	▲	▲
								P	● ●
								M	● ●
								K	● ●
								N	○ ●
								S	● ●
								H	- -

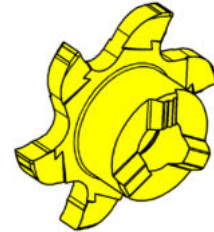
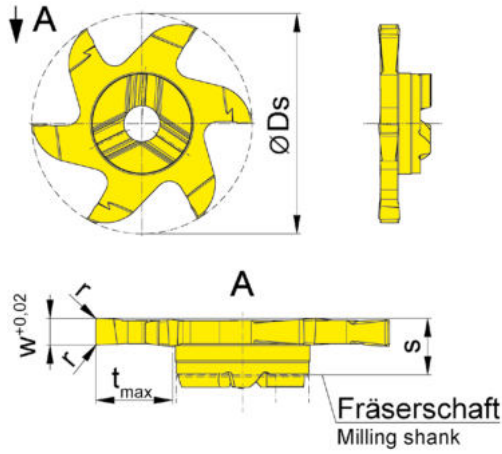
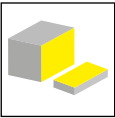

z6

B



Abbildung = rechtsschneidend
Picture = right hand cutting version

▲ ab Lager
on stock

HM-Sorten
Carbide grades
Δ 4 Wochen
4 weeks

Bestellnummer Part number	Ds	w	s	α	t _{max}	Z	HIS		AN25	RC25
632.L810.2.00	31,7	1	6,1	8°	10	6	332110R	▲	▲	
632.L815.2.00	31,7	1,5	6,1	8°	10	6	332110R	▲	▲	
632.L820.2.00	31,7	2	6,1	8°	10	6	332110R	▲	▲	
								P	●	●
								M	○	●
								K	-	●
								N	-	-
								S	-	-
								H	-	-

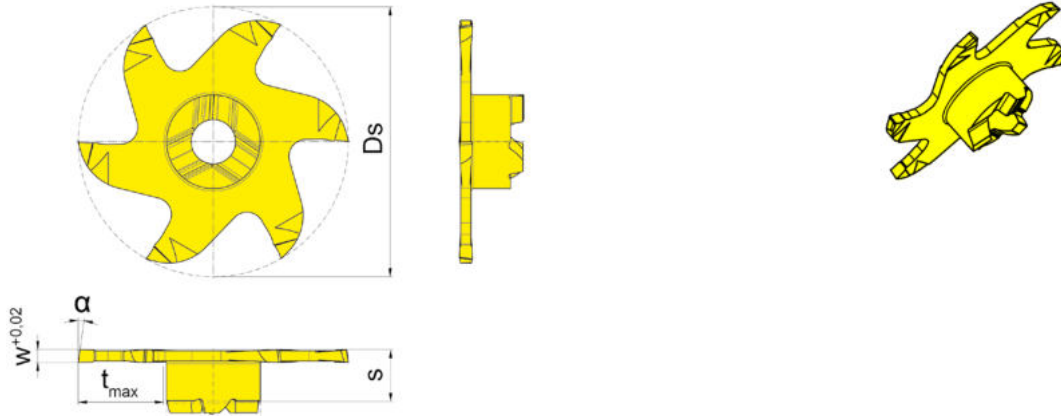
B

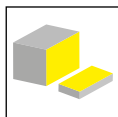

z6



Abbildung = rechtsschneidend
Picture = right hand cutting version

▲ ab Lager
on stock

HM-Sorten
Carbide grades
Δ 4 Wochen
4 weeks

Bestellnummer Part number	Ds	w	s	α	t _{max}	Z	HIS	AN25	RC25
636.L810.2.00	35,7	1	6,1	8°	12	6	332110R	▲	▲
636.L815.2.00	35,7	1,5	6,1	8°	12	6	332110R	▲	▲
636.L820.2.00	35,7	2	6,1	8°	12	6	332110R	▲	▲

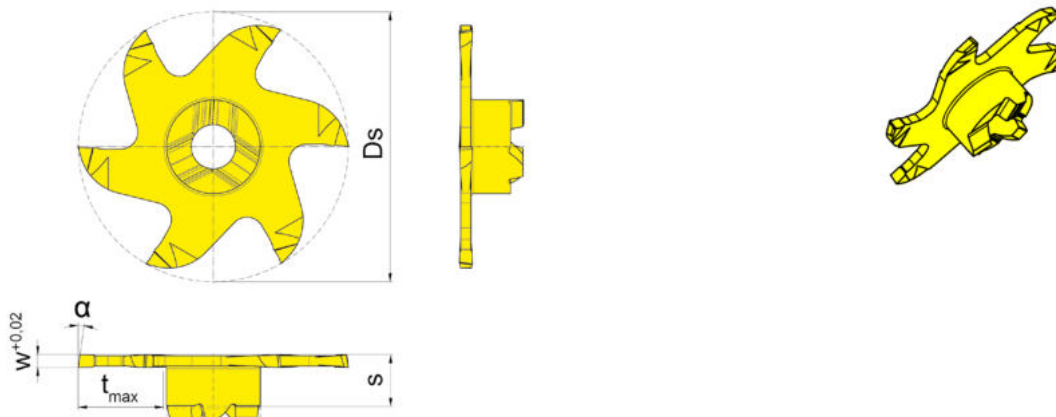
ab Schneidbreite 2,5 mm Kreuzverzahnung
from width of groove 2,5 mm toothing with cross-cut

P	●	●
M	○	●
K	-	●
N	-	-
S	-	-
H	-	-

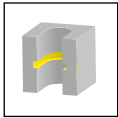

z6



Abbildung = rechtsschneidend
Picture = right hand cutting version

▲ ab Lager
on stock

HM-Sorten
Carbide grades

Δ 4 Wochen
4 weeks

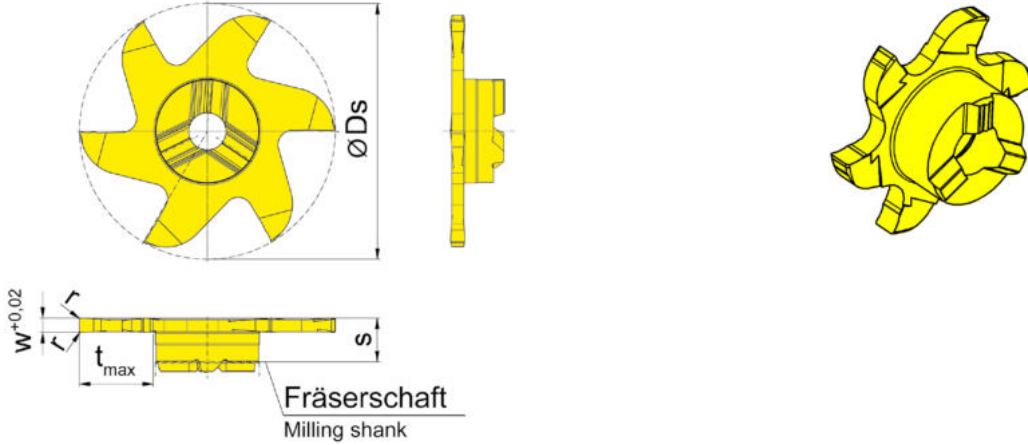
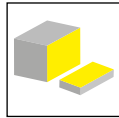
Bestellnummer Part number	Ds	w	s	r	t _{max}	Z	HIS	AS45	TA45
636.0150.00	35,7	1,5	6,1	0,1	10,2	6	332143R	▲	▲
636.0200.00	35,7	2	6,1	0,2	10,2	6	332143R	▲	▲
636.0250.00	35,7	2,5	6,1	0,2	10,2	6	332143R	▲	▲
636.0300.00	35,7	3	6,1	0,2	10,2	6	332143R	▲	▲

Bitte Verzahnungs- \varnothing d1 von Frälerschaft beachten!
Please consider pocket seat \varnothing d1 of the milling shank!

P	●	●
M	●	●
K	●	●
N	○	●
S	●	●
H	-	-

B

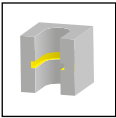

z6



Abbildung = rechtsschneidend
Picture = right hand cutting version

▲ ab Lager
on stock

HM-Sorten
Carbide grades
Δ 4 Wochen
4 weeks

Bestellnummer Part number	Ds	w	s	r	t _{max}	Z	HIS	AS45	TA45
636.0110.2.00	35,7	1,1	6,1	0,1	12	6	332110R	▲	
636.0130.2.00	35,7	1,3	6,1	0,1	12	6	332110R	Δ	
636.0150.2.00	35,7	1,5	6,1	0,1	12	6	332110R	▲	▲
636.0200.2.00	35,7	2	6,1	0,2	12	6	332110R	▲	▲
636.0250.2.00	35,7	2,5	6,1	0,2	12	6	332110R	▲	▲
								P	● ●
								M	● ●
								K	● ●
								N	○ ●
								S	● ●
								H	- -

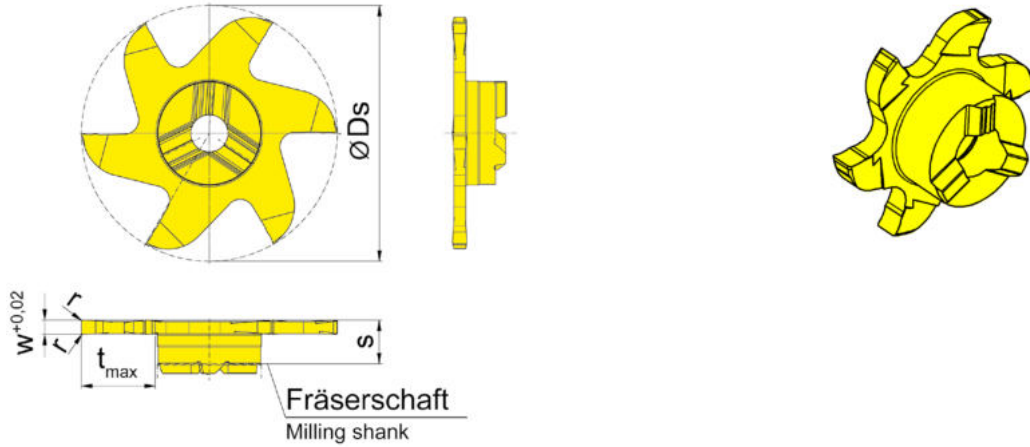
ab Schneidbreite 2,5 mm Kreuzverzahnung
from width of groove 2,5 mm toothing with cross-cut

Bitte Verzahnungs- \varnothing d1 von Fräserschaft beachten!
Please consider pocket seat \varnothing d1 of the milling shank!

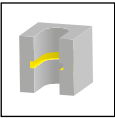

z9

B



Abbildung = rechtsschneidend
Picture = right hand cutting version

▲ ab Lager
on stock

HM-Sorten
Carbide grades

Δ 4 Wochen
4 weeks

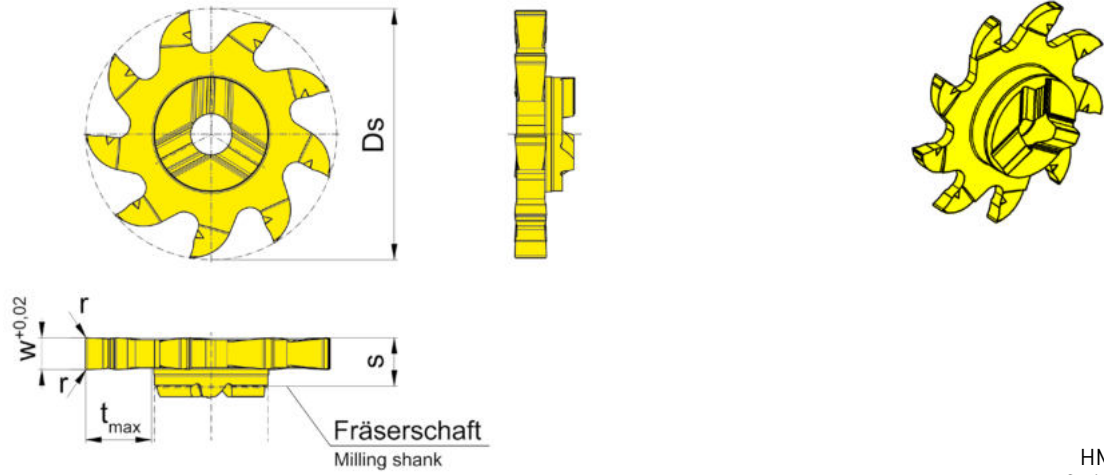
Bestellnummer Part number	D _s	w	s	r	t _{max}	Z	HIS	AS45
932.0200.00	31,7	2	6,1	0,2	8,3	9	332143R	▲
932.0250.00	31,7	2,5	6,1	0,2	8,3	9	332143R	▲
932.0300.00	31,7	3	6,1	0,2	8,3	9	332143R	▲
932.0400.00	31,7	4	6,1	0,2	8,3	9	332143R	▲
								P ●
								M ●
								K ●
								N o
								S ●
								H -

B



Abbildung = rechtsschneidend
Picture = right hand cutting version

▲ ab Lager
on stock

HM-Sorten
Carbide grades
Δ 4 Wochen
4 weeks

Bestellnummer Part number	Ds	w	s	t _{max}	Z	HIS	AN25	RC25
939.0100.3.00	40	1	5,8	13,5	9	332120R	▲	▲
939.0150.3.00	40	1,5	5,8	13,5	9	332120R	▲	▲
939.0200.3.00	40	2	5,8	13,5	9	332120R	▲	▲
939.0250.3.00	40	2,5	5,8	13,5	9	332120R	▲	▲
							P ● ●	
							M ○ ●	
							K - ●	
							N - -	
							S - -	
							H - -	

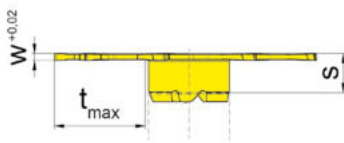
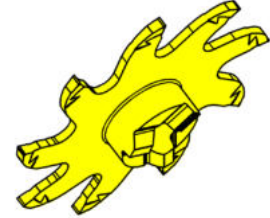
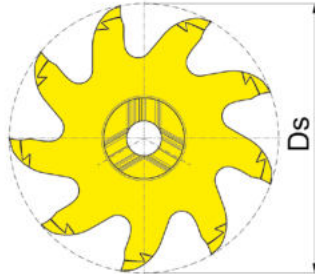
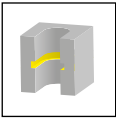

z9

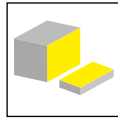

B



Abbildung = rechtsschneidend
Picture = right hand cutting version

▲ ab Lager
on stock

HM-Sorten
Carbide grades
Δ 4 Wochen
4 weeks

Bestellnummer Part number	Ds	w	s	t _{max}	Z	HIS	AN25	RC25
939.0040.4.00	40	0,4	5,8	14	9	332110R	▲	▲
939.0050.4.00	40	0,5	5,8	14	9	332110R	▲	▲
939.0060.4.00	40	0,6	5,8	14	9	332110R	▲	▲
939.0070.4.00	40	0,7	5,8	14	9	332110R	▲	▲
939.0080.4.00	40	0,8	5,8	14	9	332110R	▲	▲
939.0090.4.00	40	0,9	5,8	14	9	332110R	▲	▲
939.0100.4.00	40	1	5,8	14	9	332110R	▲	▲
939.0150.4.00	40	1,5	5,8	14	9	332110R	▲	▲
							P ● ●	
							M ○ ●	
							K - ●	
							N - -	
							S - -	
							H - -	

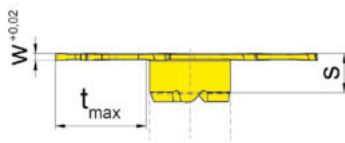
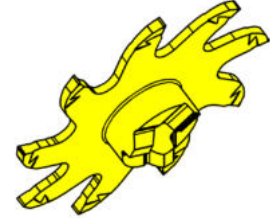
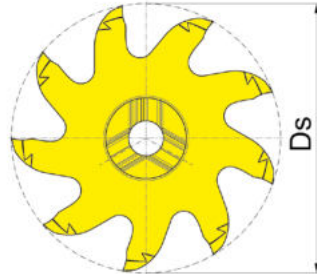
B

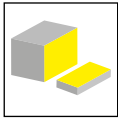

z9



Abbildung = rechtsschneidend
Picture = right hand cutting version

▲ ab Lager
on stock

HM-Sorten
Carbide grades
Δ 4 Wochen
4 weeks

Bestellnummer Part number	Ds	w	s	α	t _{max}	Z	HIS		AN25	RC25
939.L810.3.00	40	1	5,8	8°	13,5	9	332120R	▲	▲	
939.L810.4.00	40	1	5,8	8°	14	9	332110R	▲	Δ	
939.L815.4.00	40	1,5	5,8	8°	14	9	332110R	▲	Δ	
								P	●	●
								M	○	●
								K	-	●
								N	-	-
								S	-	-
								H	-	-

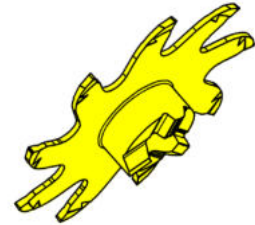
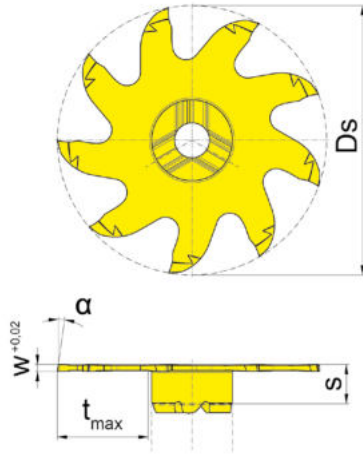
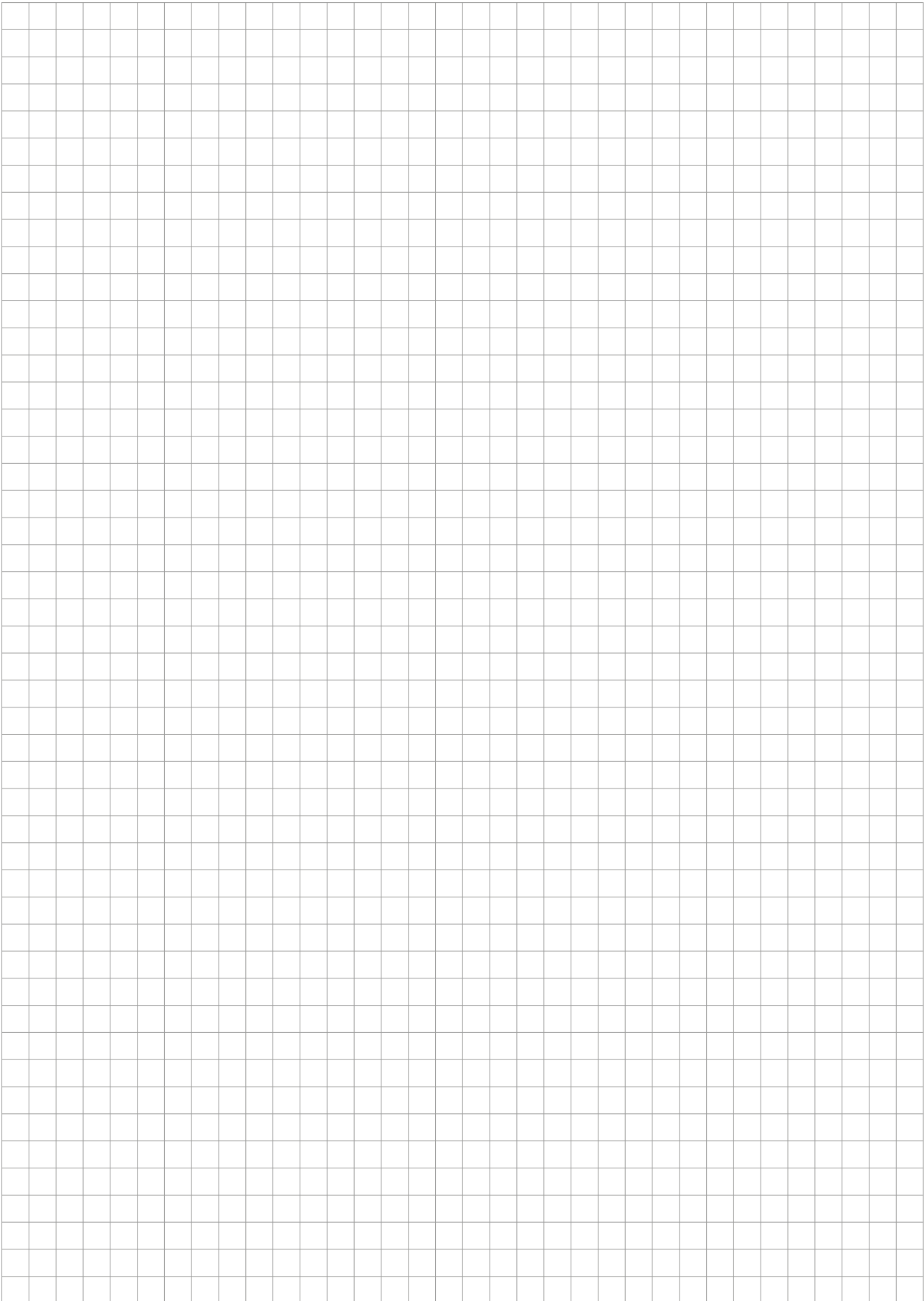

Nutfräsen (zirkular)

Groove Milling by circular interpolation

B

Frälerschaft
Milling shank
M335

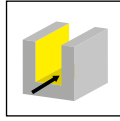

Seite/Page
202

Schneidplatte
Insert
335

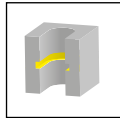

Seite/Page
203

M335



**Fräser mit wechselbarer
Schneidplatte**

ab Bohrung \varnothing 35 mm

**Milling shank with
exchangeable insert**

from bore \varnothing 35 mm

B



Abbildung = rechtsschneidend
Picture = right hand cutting version

Bestellnummer Part number	d	l ₁	l ₂	d ₁	Form	HWS
M335.0020.01A	20	100	40	17,5	A	335175R
M335.0020.02A	20	130	60	17,5	A	335175R
M335.0020.03A	20	150	80	17,5	A	335175R
M335.0020.01B	20	100	40	17,5	B	335175R
M335.0020.02B	20	130	60	17,5	B	335175R
M335.0020.02E	20	130	60	17,5	E	335175R

w, Ds, tmax siehe Schneidplatte
w, Ds, tmax see inserts

Ersatzteile
Spare Parts

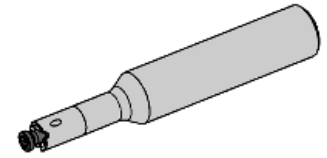
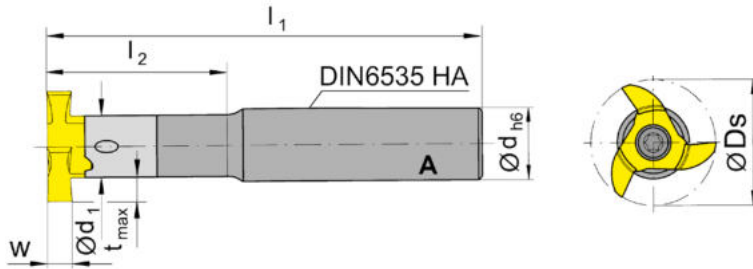
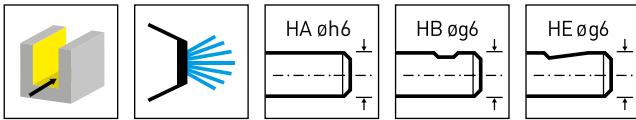
Frärschaft Milling shank	Spannschraube Clamping Screw	TORX PLUS®-Schlüssel TORX PLUS® Wrench
M335...	6.17T25P	T25PQ

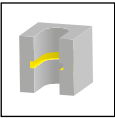

z3

B



Abbildung = rechtsschneidend
Picture = right hand cutting version

▲ ab Lager
on stock

HM-Sorten
Carbide grades
Δ 4 Wochen
4 weeks

Bestellnummer Part number	Ds	w	s	r	t _{max}	Z	HIS	AS45	TI25
335.0200.00	34,7	2	8,7	0,2	8	3	335175R	▲	▲
335.0300.00	34,7	3	8,7	0,2	8	3	335175R	▲	▲
335.0400.00	34,7	4	8,7	0,2	8	3	335175R	▲	▲
335.0500.00	34,7	5	8,7	0,2	8	3	335175R	▲	▲
335.0600.00	34,7	6	8,7	0,2	8	3	335175R	▲	▲

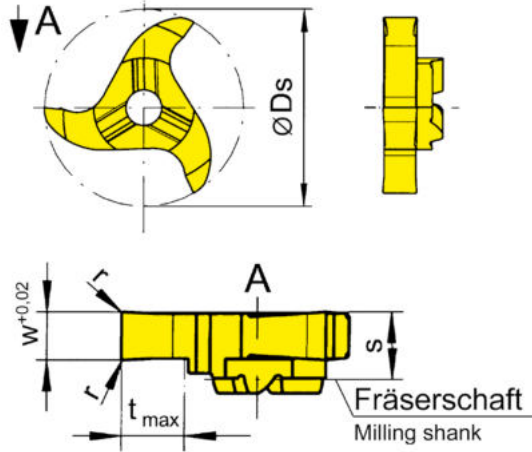
Auf Anfrage:

Schneidplatten mit 8,0 - 15,0 mm Breite nur als Formplatten, abhängig vom zu zerspanenden Werkstoff, lieferbar!

Upon request:

Insert widths of 8,0 - 15,0 mm are only available as special profiled inserts. Use of these widths depend from the workpiece material to be machined.

	AS45	TI25
P	●	●
M	●	●
K	●	●
N	○	●
S	●	●
H	-	-

Fräserschaft
Milling shank
M620

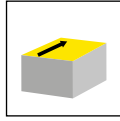

Seite/Page
206

Schneidplatte
Insert
620

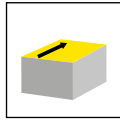

Seite/Page
207-208

M620



**Fräser mit wechselbarer
Schneidplatte**

Schneidkreis Ø 21,7 mm

**Milling shank with
exchangeable insert**

Cutting edge Ø 21,7 mm

Fräuserschaft

Milling shank

M620



B

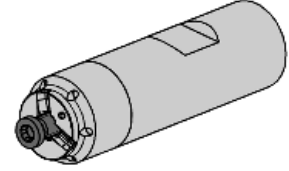
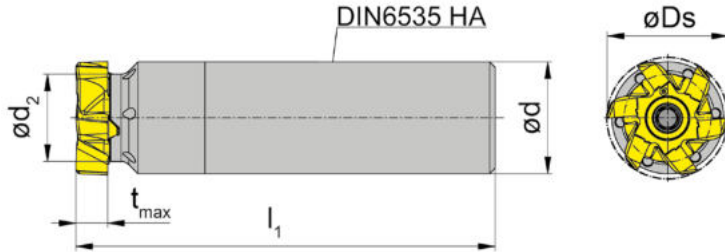
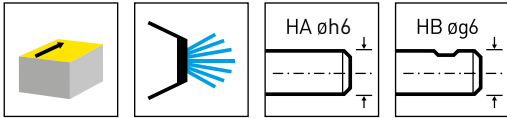

Bestellnummer Part number	Ds	d	l_1	d_2	Form	HWS
M620.0020.D.00A	21,7	20	75	15,6	A	620156R
M620.0020.D.00B	21,7	20	75	15,6	B	620156R
M620.0020.D.04A	21,7	20	130	15,6	A	620156R
M620.0020.D.04B	21,7	20	130	15,6	B	620156R

t_{max} siehe Schneidplatten
 t_{max} see inserts

Ersatzteile

Spare Parts

Fräuserschaft Milling shank	Spannschraube Clamping Screw	TORX PLUS®-Schlüssel TORX PLUS® Wrench
M620...	5.14T20P	T20PQ

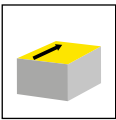

z6

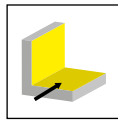

B

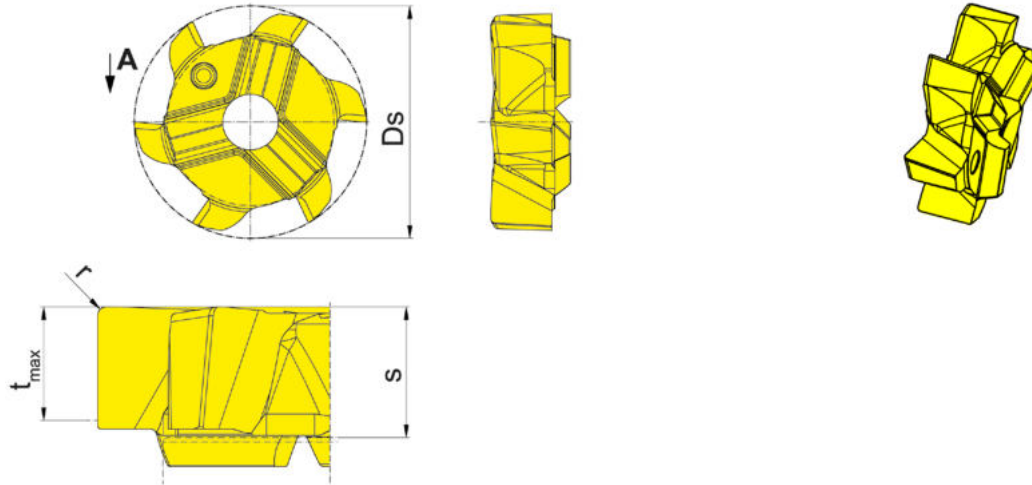

HM-Sorten
Carbide grades

▲ ab Lager
on stock

Δ 4 Wochen
4 weeks

Bestellnummer Part number	Ds	Z	r	t _{max}	s	HIS	AS45
620.PL53.64	21,7	6	0,4	5,3	6,1	620156R	▲
							P ●
							M ●
							K ●
							N ○
							S ●
							H -

B

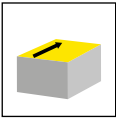

z6

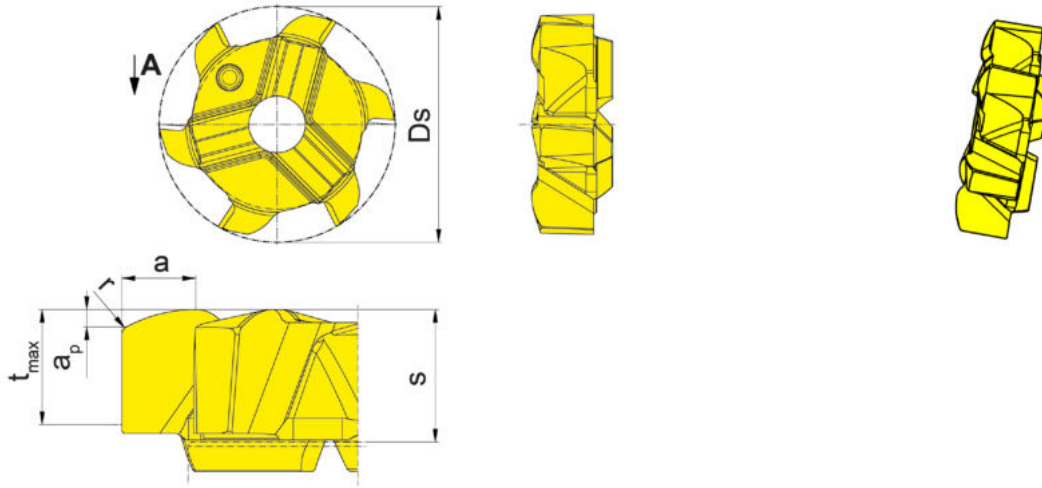

HM-Sorten
Carbide grades

▲ ab Lager
on stock

Δ 4 Wochen
4 weeks

Bestellnummer Part number	Ds	a	Z	r	t _{max}	a _p	s	HIS	AS45
620.HV08.04	21,7	4,4	6	0,4	5,3	0,8	6,1	620156R	▲
									P ●
									M ●
									K ●
									N ○
									S ●
									H -

Hochvorschubfräsen
High Feed Milling

Eintauchwinkel Diving angle	theoretischer Eckenradius r _{th} = Programmerradius theoretical corner radius r _{th} = programming radius	max. Abweichung max. difference
1°	1,15 mm	0,43 mm

M275



C

Nutfräser

ab Schneidkreis \varnothing 31 mm

Groove milling cutter

from cutting edge \varnothing 31 mm

Nutfräsen (zirkular)

Groove Milling by circular interpolation

C

Schaftfräser
End Mill
M275

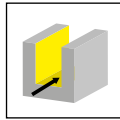

Seite/Page
211

Einschraubfräser
Screw-in cutter
M275

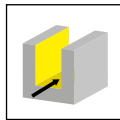

Seite/Page
212

Aufsteckfräser
Arbour Mounted Cutter
M275

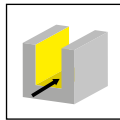

Seite/Page
213

Scheibenfräser
Disc Milling Cutter
M275

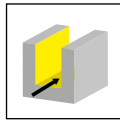

Seite/Page
214

Wendeschneidplatte
Indexable insert
S275/RS275

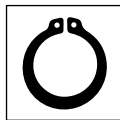

Seite/Page
215-217

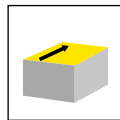

Seite/Page
218



Abbildung = rechtsschneidend
Picture = right hand cutting version

Bestellnummer Part number	Z	Ds	d	l ₁	λ	HWS
M275.031.D25.3.04A	4	31	25	125	4°	275041R

w und tmax siehe WSP
w and tmax see inserts

Schaftmaterial: Stahl (nicht schrumpfbar)
Material of shank: Steel (not recommended for shrink fitting)

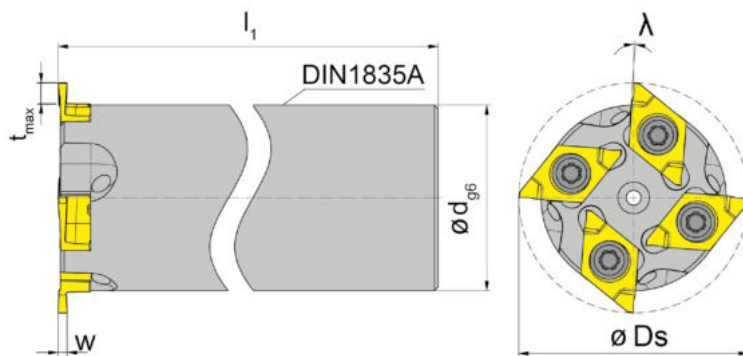
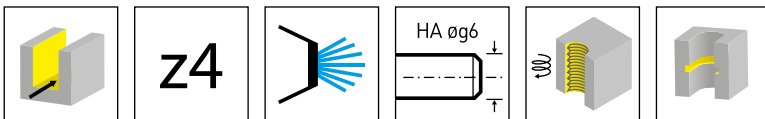
Ersatzteile
Spare Parts

Schaftfräser End Mill	Spannschraube Clamping Screw	TORX PLUS®-Schlüssel TORX PLUS® Wrench
M275.031.D25.3.04A	3.5.10T10P	T10PL



Abbildung = rechtsschneidend
Picture = right hand cutting version

Bestellnummer Part number	Z	Ds	l ₁	l ₂	d ₁	d ₄	SW	HWS
M275.031.M16.1.04	4	31	45	22	25	29	24	275041R
M275.036.M16.1.04	4	36	45	22	30	29	27	275041R

w und tmax siehe WSP
w and tmax see inserts

Ersatzteile
Spare Parts

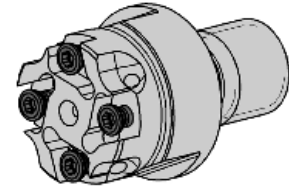
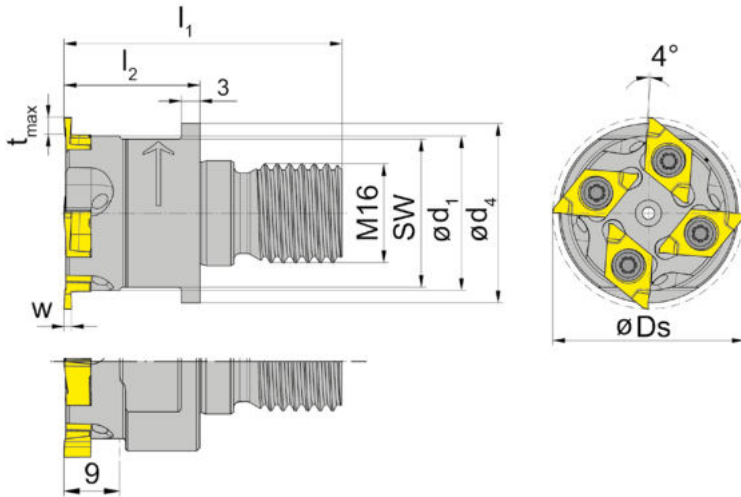
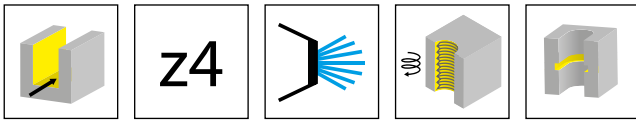
Einschraubfräser Screw-in cutter	Spannschraube Clamping Screw	TORX PLUS®-Schlüssel TORX PLUS® Wrench
M275...	3.5.10T10P	T10PL



Abbildung = rechtsschneidend
Picture = right hand cutting version

Bestellnummer Part number	Z	Ds	h ₂	h	d ₅	d ₄	d ₃	l ₁	l ₂	b	C	d ₂	HWS
M275.0038.A16.05	5	38	32,7	33	13,5	32	16	18	22,7	8,4	5,6	32	275041R
M275.0048.A22.08	8	48	36,7	37	18,5	40,5	22	20	24,7	10,4	6,3	40,5	275041R
M275.0058.A27.10	10	58	42,2	42,5	22	48	27	22	27,2	12,4	7	50	275041R
M275.0078.A32.14	14	78	49,7	50	33	58	32	25	36,7	14,4	8	70,5	275041R

w und tmax siehe WSP
w and tmax see inserts

Aufnahmebohrung und Mitnahme nach DIN 138
Cutterhole and cross keyway as per DIN 138

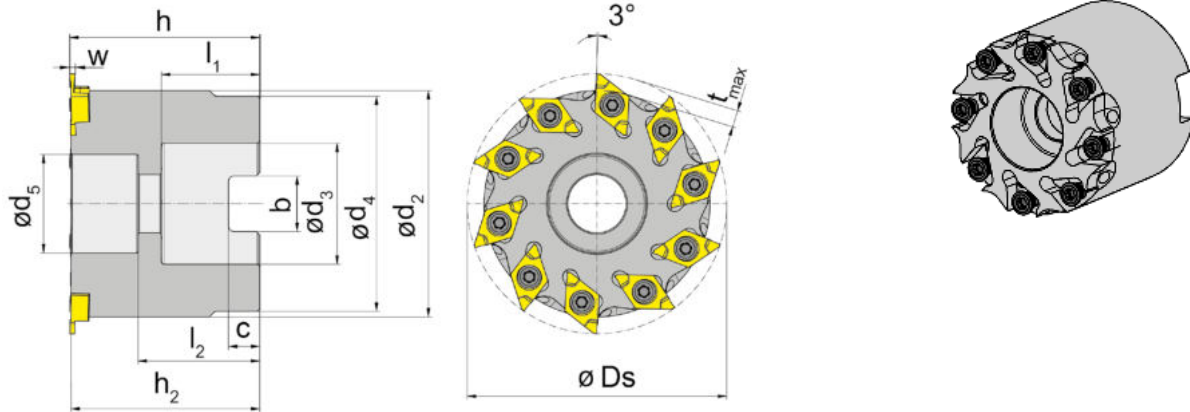
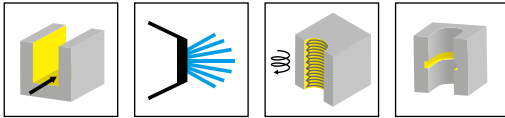
Ersatzteile
Spare Parts

Aufsteckfräser Arbour Mounted Cutter	Spannschraube Clamping Screw	TORX PLUS®-Schlüssel TORX PLUS® Wrench
M275...	3.5.10T10P	T10PL

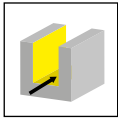

C

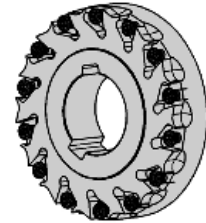
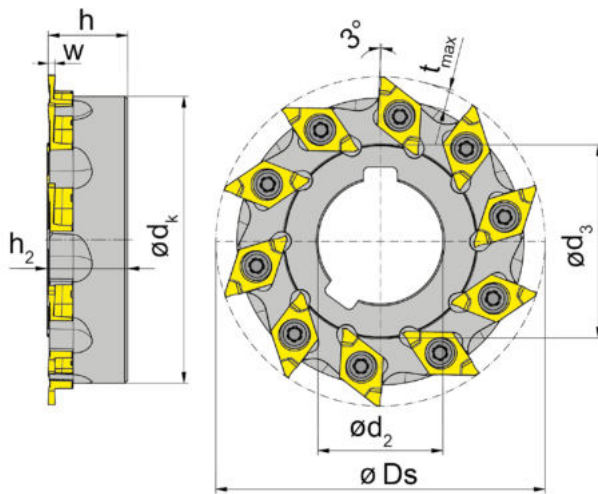

R = rechtsschneidend, wie gezeichnet
R = right hand cutting version shown

L = linksschneidend
L = left hand cutting version

Bestellnummer Part number	Z	Ds	d ₂	d ₃	d _k	h ₂	h	HWS
RM275.0058.S22.10	10	58	22	34	50,5	14,2	14	275041R
RM275.0098.S32.16	16	98	32	48	90,5	20,2	20	275041R
LM275.0058.S22.10	10	58	22	34	50,5	14,2	14	275041L
LM275.0078.S27.14	14	78	27	43	70,5	16,2	16	275041L
LM275.0098.S32.16	16	98	32	48	90,5	20,2	20	275041L

w und tmax siehe WSP
w and tmax see inserts

Bohrung (d₂) mit Längsnut nach DIN 138
Bore (d₂) with longitudinal keyway to DIN 138

Ersatzteile

Spare Parts

Scheibenfräser Disc Milling Cutter	Spannschraube Clamping Screw	TORX PLUS®-Schlüssel TORX PLUS® Wrench
R/LM275.0...	3.5.10T10P	T10PL

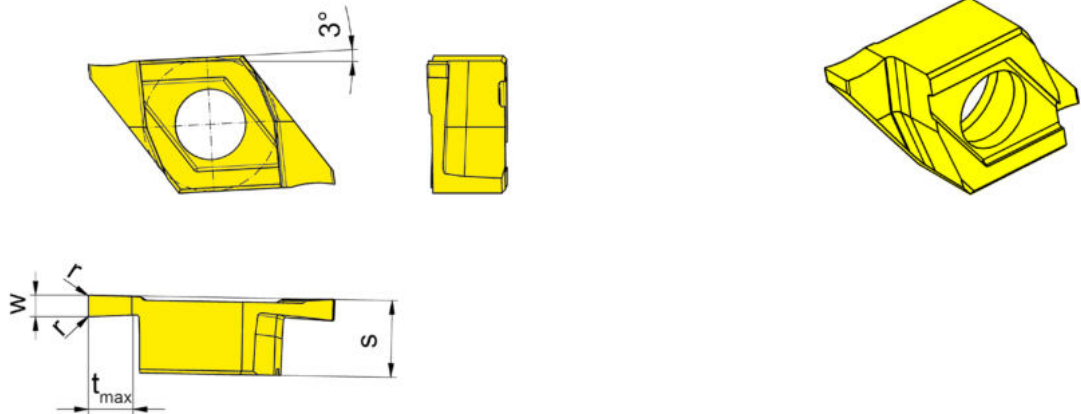
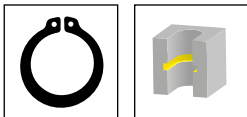

R = rechts wie gezeichnet
R = right hand version shown

L = links spiegelbildlich
L = left hand version

▲ ab Lager
on stock

HM-Sorten
Carbide grades
Δ 4 Wochen
4 weeks

Bestellnummer Part number	Nw	w	s	r	t _{max}	HIS	AS45
RS275.0110.00	1,1	1,2	4,3	0,1	2,5	275043R	Δ
RS275.0130.00	1,3	1,4	4,3	0,1	2,5	275043R	▲
RS275.0160.00	1,6	1,7	4,3	0,1	2,5	275043R	▲
RS275.0185.00	1,85	1,95	4,3	0,15	2,5	275043R	▲
RS275.0215.00	2,15	2,25	4,3	0,15	2,5	275043R	▲
RS275.0265.00	2,65	2,75	4,3	0,15	2,5	275043R	▲
RS275.0315.00	3,15	3,25	4,3	0,15	2,5	275043R	▲
LS275.0130.00	1,3	1,4	4,3	0,1	2,5	275043L	Δ
LS275.0160.00	1,6	1,7	4,3	0,1	2,5	275043L	Δ
LS275.0265.00	2,65	2,75	4,3	0,15	2,5	275043L	▲
LS275.0315.00	3,15	3,25	4,3	0,15	2,5	275043L	Δ
							P ●
							M ●
							K ●
							N ○
							S ●
							H -



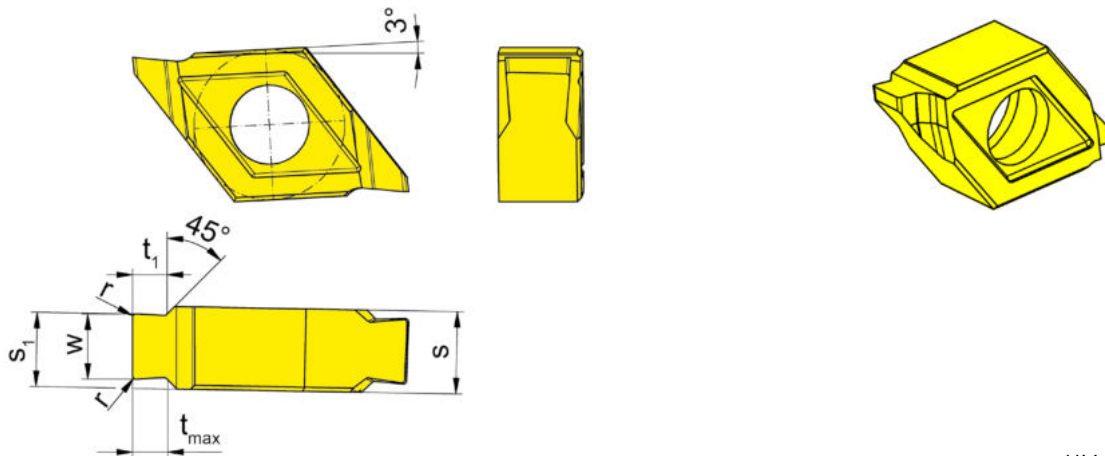
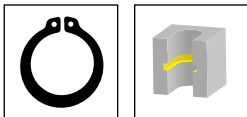

R = rechts wie gezeichnet
R = right hand version shown

L = links spiegelbildlich
L = left hand version

▲ ab Lager
on stock

HM-Sorten
Carbide grades
Δ 4 Wochen
4 weeks

Bestellnummer Part number	Nw	w	t ₁	s	s ₁	r	t _{max}	HIS	AS45
RS275.1610.41	1,6	1,7	0,95	4,1	3,17	0,1	1	275041R	▲
RS275.1812.41	1,85	1,95	1,21	4,1	3,29	0,15	1,25	275041R	▲
RS275.2115.41	2,15	2,25	1,45	4,1	3,44	0,15	1,5	275041R	▲
RS275.2617.41	2,65	2,75	1,7	4,1	3,39	0,15	1,75	275041R	▲
RS275.3118.41	3,15	3,25	1,7	4,1	3,7	0,15	1,75	275041R	▲
LS275.3118.41	3,15	3,25	1,7	4,1	3,7	0,15	1,75	275041L	Δ
									P ●
									M ●
									K ●
									N ○
									S ●
									H -

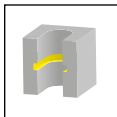

.40

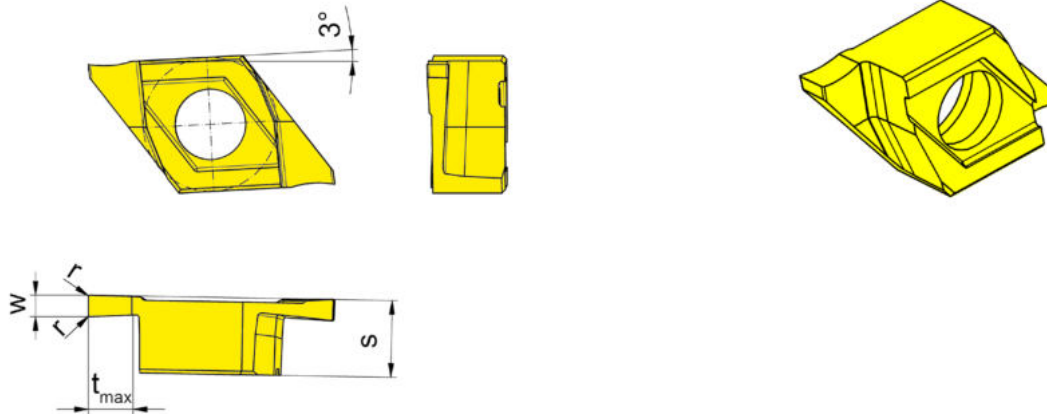

R = rechts wie gezeichnet
R = right hand version shown

L = links spiegelbildlich
L = left hand version

▲ ab Lager
on stock

HM-Sorten
Carbide grades
Δ 4 Wochen
4 weeks

Bestellnummer Part number	Nw	w	s	r	t _{max}	HIS	TA45
RS275.0110.40	1,1	1,2	4,3	0,1	2,5	275043R	Δ
RS275.0130.40	1,3	1,4	4,3	0,1	2,5	275043R	▲
RS275.0185.40	1,85	1,95	4,3	0,15	2,5	275043R	▲
RS275.0215.40	2,15	2,25	4,3	0,15	2,5	275043R	Δ
RS275.0265.40	2,65	2,75	4,3	0,15	2,5	275043R	Δ
RS275.0315.40	3,15	3,25	4,3	0,15	2,5	275043R	Δ
LS275.0110.40	1,1	1,2	4,3	0,1	2,5	275043L	Δ
LS275.0130.40	1,3	1,4	4,3	0,1	2,5	275043L	Δ
LS275.0160.40	1,6	1,7	4,3	0,1	2,5	275043L	Δ
LS275.0185.40	1,85	1,95	4,3	0,15	2,5	275043L	Δ
LS275.0215.40	2,15	2,25	4,3	0,15	2,5	275043L	Δ
LS275.0265.40	2,65	2,75	4,3	0,15	2,5	275043L	Δ
LS275.0315.40	3,15	3,25	4,3	0,15	2,5	275043L	Δ

P	●
M	●
K	●
N	●
S	●
H	-



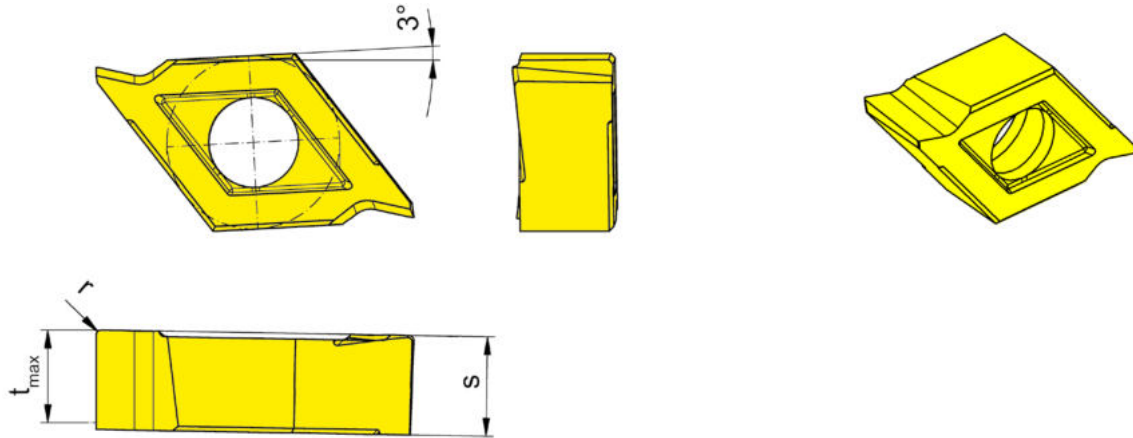
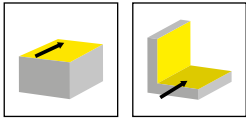

R = rechts wie gezeichnet
R = right hand version shown

▲ ab Lager
on stock

HM-Sorten
Carbide grades
Δ 4 Wochen
4 weeks

Bestellnummer Part number	r	t _{max}	s	HIS	AS45	TA45
RS275.PL40.62	0,15	4	4,3	275043R		▲
RS275.PL43.52	0,2	4	4,3	275043R	▲	
					P ● ●	
					M ● ●	
					K ● ●	
					N ○ ●	
					S ● ●	
					H - -	

M380/M381



D

Fräuserschaft
Aufsteckfräser
Monoblockfräser
Scheibenfräser

ab Bohrung \varnothing 45 mm

Milling Shank
Arbor Mounted Cutter
Mono Milling Cutter
Disc Milling Cutter

from bore \varnothing 45 mm

Nutfräsen (zirkular)

Groove Milling by circular interpolation

Schaftfräser
End Mill
380

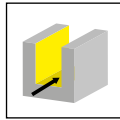

Seite/Page
221

Aufsteckfräser
Arbour Mounted Cutter
380/380...IK

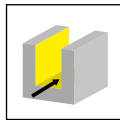

Seite/Page
222-225

Monoblockfräser
Mono Milling Cutter
HSK380/ABS..380

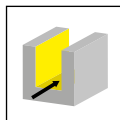

Seite/Page
226

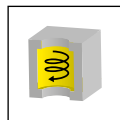

Seite/Page
227

Scheibenfräser
Disc Milling Cutter
381

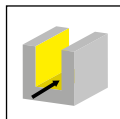

Seite/Page
228

Wendeschneidplatte
Indexable insert
314

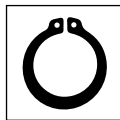

Seite/Page
229-231

D



Abbildung = rechtsschneidend
Picture = right hand cutting version

Bestellnummer Part number	Z	Ds	d	l ₁	d ₁	λ	Form	HWS
380.0044.03A	3	44	25	125	34	14°	A	314027R • 314041R • 314052R
380.0044.03B	3	44	25	125	34	14°	B	314027R • 314041R • 314052R
380.0044.03E	3	44	25	125	34	14°	E	314027R • 314041R • 314052R

t_{max} siehe Schneidplatten
t_{max} see inserts

Ersatzteile

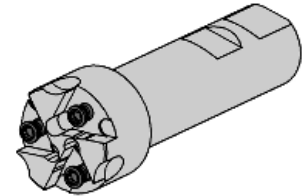
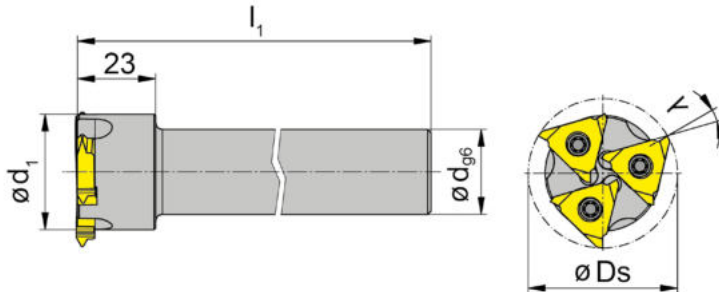
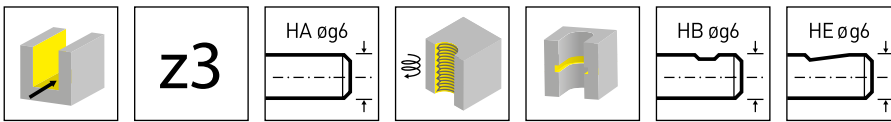
Spare Parts

Schaftfräser End Mill	Spannschraube Clamping Screw	TORX PLUS®-Schlüssel TORX PLUS® Wrench
380...	5.12T20P	T20PQ





Abbildung = rechtsschneidend
Picture = right hand cutting version

Bestellnummer Part number	Z	Ds	h ₂	h	d ₃	l ₁	l ₂	λ	d ₂	HWS
380.0063.05	5	63	39,6	40	22	20	27,6	10°	51	314027R • 314041R • 314052R

Aufnahmebohrung und Mitnahme nach DIN 138
Cutterhole and cross keyway as per DIN 138

t_{max} siehe Schneidplatten
t_{max} see inserts

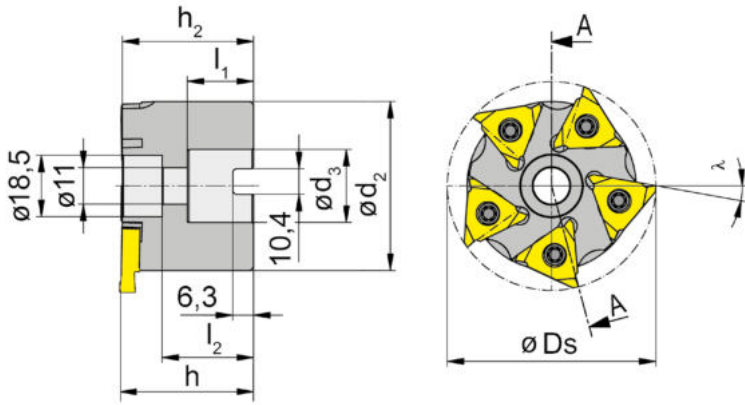
Ersatzteile
Spare Parts

Aufsteckfräser Arbour Mounted Cutter	Spannschraube Clamping Screw	TORX PLUS®-Schlüssel TORX PLUS® Wrench
380.0063.05	5.12T20P	T20PQ



Abbildung = rechtsschneidend
Picture = right hand cutting version

Bestellnummer Part number	Z	Ds	h ₂	h	d ₃	l ₁	l ₂	λ	d ₂	HWS
380.0063.05IK	5	63	39,6	40	22	20	27,6	10°	51	314027R • 314041R • 314052R

Aufnahmebohrung und Mitnahme nach DIN 138
Cutterhole and cross keyway as per DIN 138

t_{max} siehe Schneidplatten
t_{max} see inserts

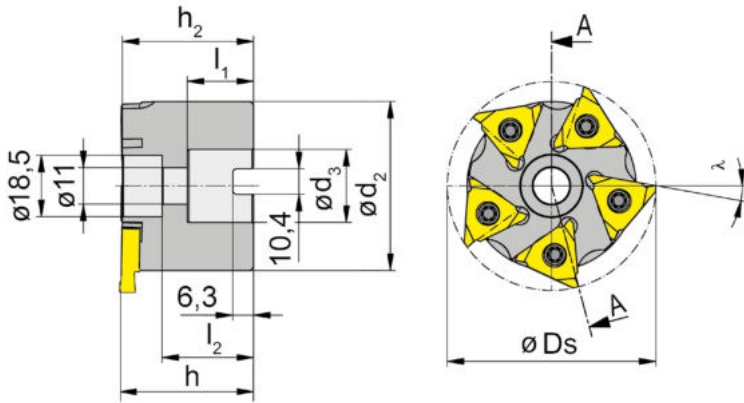
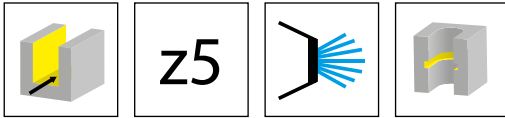
Fräsdorn gehört nicht zum Lieferumfang. Bitte separat bestellen!
Milling arbor is not combined with milling cutter - separate order required!

Ersatzteile
Spare Parts

Aufsteckfräser Arbour Mounted Cutter	Spannschraube Clamping Screw	TORX PLUS®-Schlüssel TORX PLUS® Wrench
380.0063.05IK	5.12T20P	T20PQ





Abbildung = rechtsschneidend
Picture = right hand cutting version

Bestellnummer Part number	Z	Ds	t _{max}	h ₂	h	d ₃	l ₂	λ	d ₂	HWS
380.0080.08	8	80	5	31,6	32	27	21,6	10°	68	314027R • 314041R • 314052R

Aufnahmebohrung und Mitnahme nach DIN 138
Cutterhole and cross keyway as per DIN 138

Fräseranzugsschraube **030.0012.0726** gehört zum Lieferumfang.
Bolt screw 030.0012.0726 is combined with the milling cutter.

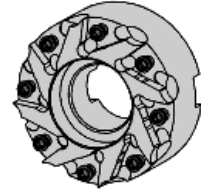
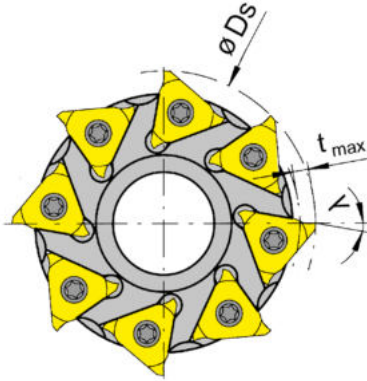
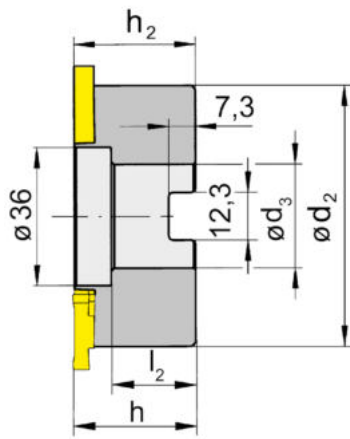
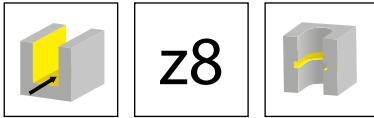
Ersatzteile
Spare Parts

Aufsteckfräser Arbour Mounted Cutter	Spannschraube Clamping Screw	TORX PLUS®-Schlüssel TORX PLUS® Wrench
380.0080.08	5.12T20P	T20PQ



Abbildung = rechtsschneidend
Picture = right hand cutting version

Bestellnummer Part number	Z	Ds	t _{max}	h ₂	h	d ₃	l ₂	λ	d ₂	HWS
380.0080.08IK	8	80	5	39,8	40	27	21,6	10°	68	314027R • 314041R • 314052R

Aufnahmebohrung und Mitnahme nach DIN 138
Cutterhole and cross keyway as per DIN 138

Fräseranzugsschraube **030.0012.0726** gehört zum Lieferumfang.
Bolt screw 030.0012.0726 is combined with the milling cutter.

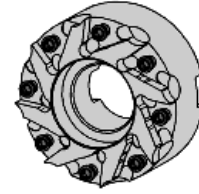
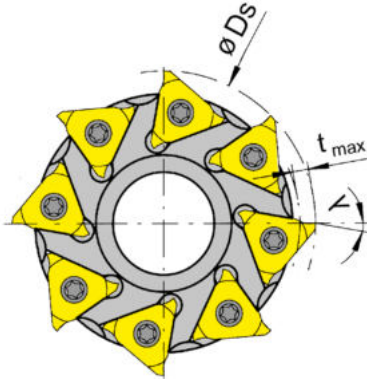
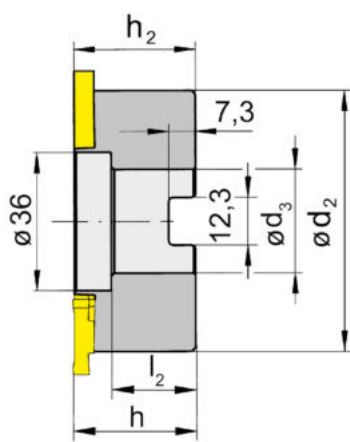
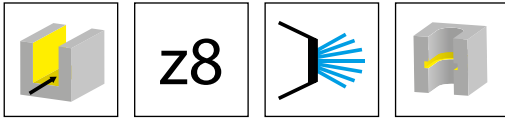
Ersatzteile
Spare Parts

Aufsteckfräser Arbour Mounted Cutter	Spannschraube Clamping Screw	TORX PLUS®-Schlüssel TORX PLUS® Wrench
380.0080.08IK	5.12T20P	T20PQ





Abbildung = rechtsschneidend
Picture = right hand cutting version

Bestellnummer Part number	D_s	Z	t_{max}	h	d_2	λ	HWS
HSK32-380.0044.03	44	3	3	55	34	14°	314027R • 314041R • 314052R
HSK40-380.0050.04	50	4	4	55	40	14°	314027R • 314041R • 314052R
HSK40-380.0063.05	63	5	5	55	51	10°	314027R • 314041R • 314052R
HSK50-380.0063.05	63	5	5	65	51	10°	314027R • 314041R • 314052R
HSK50-380.0080.08	80	8	8	65	68	10°	314027R • 314041R • 314052R
HSK63-380.0080.08	80	8	8	70	68	10°	314027R • 314041R • 314052R

Ersatzteile

Spare Parts

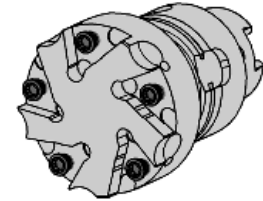
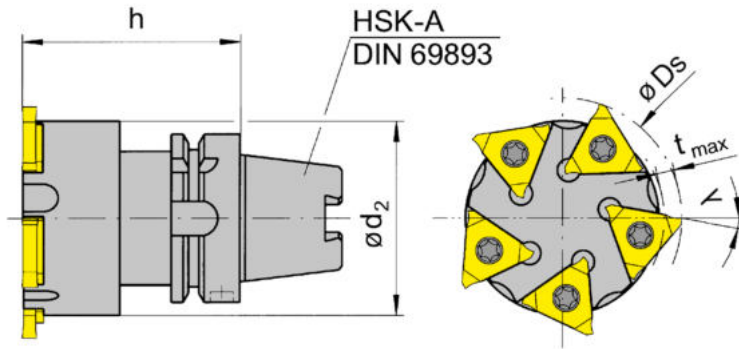
Monoblockfräser Mono Milling Cutter	Spannschraube Clamping Screw	TORX PLUS®-Schlüssel TORX PLUS® Wrench
HSK...	5.12T20P	T20PQ



Abbildung = rechtsschneidend
Picture = right hand cutting version

Bestellnummer Part number	Ds	Z	λ	HWS
ABS32.380.0044.03	44	3	14°	314027R • 314041R • 314052R
ABS40-380.0050.04	50	4	14°	314027R • 314041R • 314052R
ABS50.380.0063.05	63	5	10°	314027R • 314041R • 314052R
ABS50.380.0080.08	80	8	10°	314027R • 314041R • 314052R
ABS63.380.0080.08	80	8	10°	314027R • 314041R • 314052R

Ersatzteile

Spare Parts

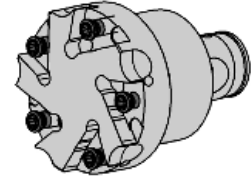
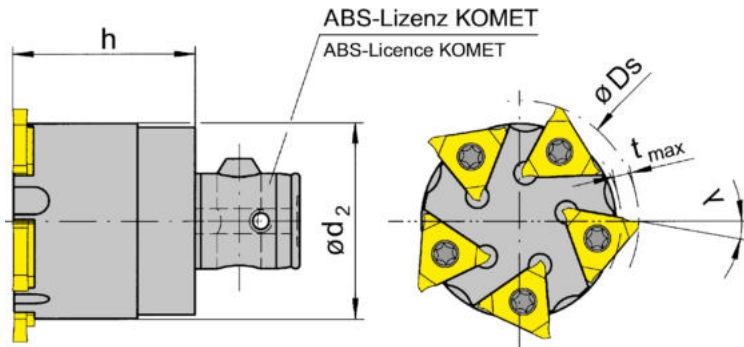
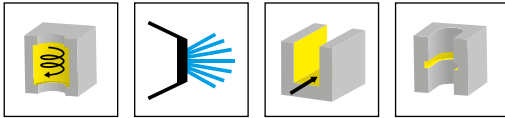
Monoblockfräser Mono Milling Cutter	Spannschraube Clamping Screw	TORX PLUS®-Schlüssel TORX PLUS® Wrench
ABS...	5.12T20P	T20PQ



Abbildung = rechtsschneidend
Picture = right hand cutting version

Bestellnummer Part number	Z	Ds	d ₂	h ₂	h	d _k	λ	d ₃	HWS
R381.0063.05	5	63	22	14,2	14	51	14°	34	314027R • 314041R • 314052R
R381.0080.08	8	80	27	16,2	16	68	10°	43	314027R • 314041R • 314052R
R381.0100.10	10	100	32	20,2	20	88	10°	48	314027R • 314041R • 314052R
L381.0063.05	5	63	22	14,2	14	51	14°	34	314027L • 314041L • 314052L
L381.0080.08	8	80	27	16,2	16	68	10°	43	314027L • 314041L • 314052L
L381.0100.10	10	100	32	20,2	20	88	10°	48	314027L • 314041L • 314052L

Bohrung (d₂) mit Längsnut nach DIN 138
Bore (d₂) with longitudinal keyway to DIN 138

t_{max} siehe Schneidplatten
t_{max} see inserts

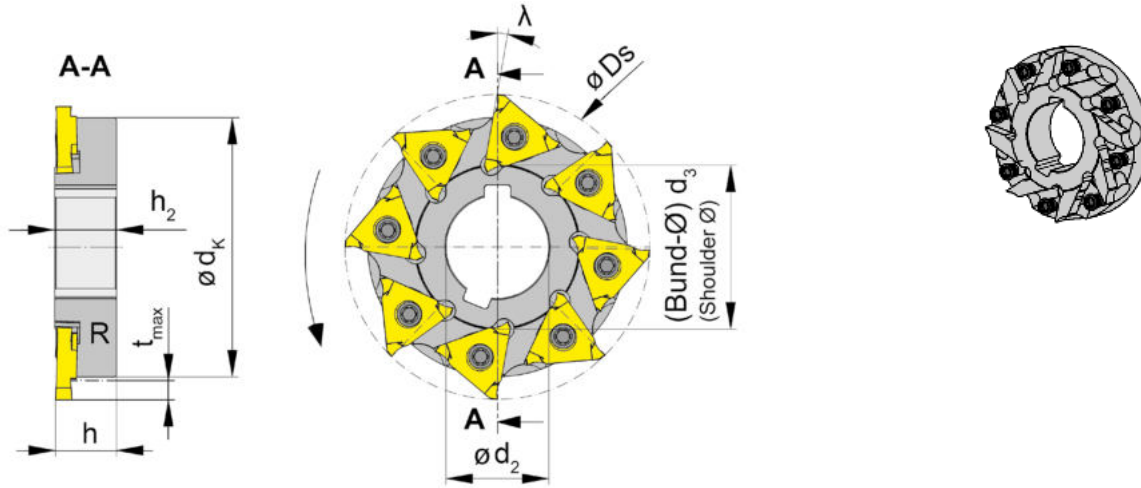
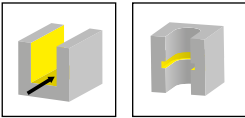
Ersatzteile

Spare Parts

Scheibenfräser Disc Milling Cutter	Spannschraube Clamping Screw	TORX PLUS®-Schlüssel TORX PLUS® Wrench
R/L381...	5.12T20P	T20PQ

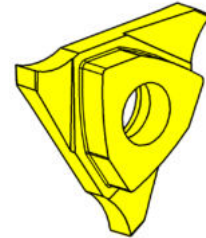
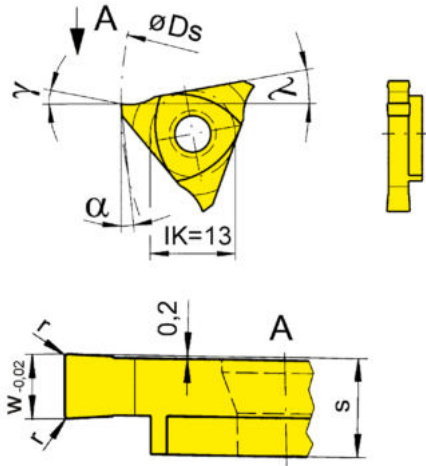
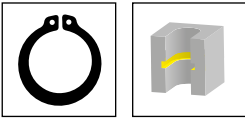

R = rechts wie gezeichnet
R = right hand version shown

L = links spiegelbildlich
L = left hand version

▲ ab Lager
on stock

HM-Sorten
Carbide grades
△ 4 Wochen
4 weeks

Bestellnummer Part number	Nw	w	r	s	HIS	MG12	AS45	TI25	TN35
R314.0130.00	1,3	1,41	0,1	5,4	314027R		▲		▲
R314.0160.00	1,6	1,71	0,1	5,4	314027R		▲		▲
R314.0185.00	1,85	1,96	0,15	5,4	314027R		▲		▲
R314.0215.00	2,15	2,26	0,15	5,4	314027R	▲	▲		▲
R314.0265.00	2,65	2,76	0,15	5,4	314027R	▲	▲	▲	▲
R314.0315.00	3,15	3,26	0,15	5,4	314027R	▲	▲	▲	▲
R314.0415.00	4,15	4,26	0,15	5,4	314041R	▲	▲	▲	▲
R314.0515.00	5,15	5,26	0,15	5,4	314052R	▲	▲	▲	▲
L314.0130.00	1,3	1,41	0,1	5,4	314027L				▲
L314.0160.00	1,6	1,71	0,1	5,4	314027L				▲
L314.0185.00	1,85	1,96	0,15	5,4	314027L		▲		
L314.0215.00	2,15	2,26	0,15	5,4	314027L	△	▲		
L314.0265.00	2,65	2,76	0,15	5,4	314027L	△			▲
L314.0315.00	3,15	3,26	0,15	5,4	314027L	△	▲		▲
L314.0415.00	4,15	4,26	0,15	5,4	314041L	△	△		▲
L314.0515.00	5,15	5,26	0,15	5,4	314052L	△	▲		▲

Geometrie in Abhängigkeit des Einlegewinkel λ
Geometrie depending on angle of seating λ

λ	γ	α
10°	15°	6°
14°	11°	10°

P	o	•	•	•
M	-	•	•	•
K	-	•	•	•
N	-	o	•	•
S	-	•	•	•
H	-	-	-	-

D

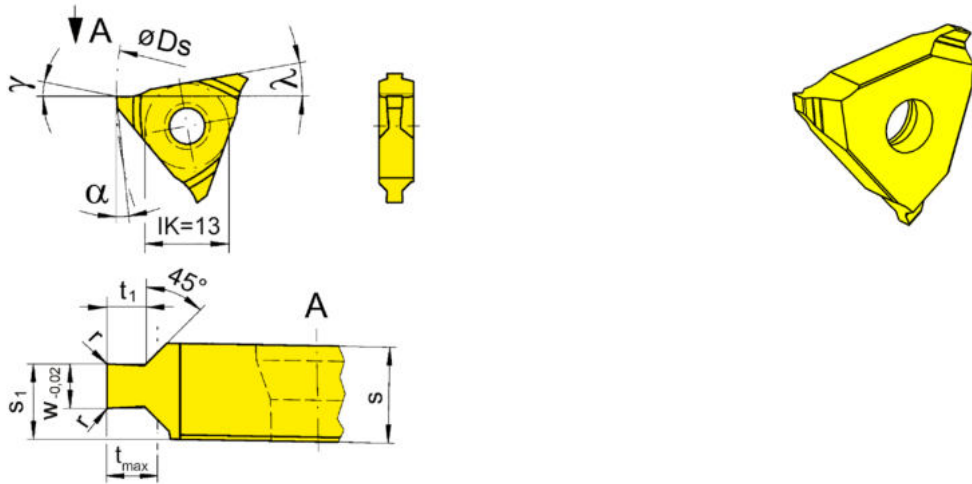
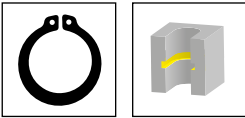

D

R = rechts wie gezeichnet
R = right hand version shown

L = links spiegelbildlich
L = left hand version

▲ ab Lager
on stock

HM-Sorten
Carbide grades
Δ 4 Wochen
4 weeks

Bestellnummer Part number	Nw	w	r	s ₁	s	t _{max}	t ₁	HIS	AS45	TN35
R314.1105.54	1,1	1,21	0,1	4,52	5,45	0,5	0,49	314041R		
R314.1307.54	1,3	1,41	0,1	4,62	5,45	0,75	0,67	314041R	Δ	Δ
R314.1308.54	1,3	1,41	0,1	4,62	5,45	0,85	0,83	314041R		
R314.1609.54	1,6	1,71	0,1	4,52	5,45	0,85	0,83	314041R	▲	▲
R314.1610.54	1,6	1,71	0,1	4,52	5,45	1	0,97	314041R	Δ	Δ
R314.1812.54	1,85	1,96	0,15	4,64	5,45	1,25	1,23	314041R	▲	▲
R314.2115.54	2,15	2,26	0,15	4,79	5,45	1,5	1,47	314041R	▲	▲
R314.2616.54	2,65	2,76	0,15	4,54	5,45	1,5	1,47	314041R	▲	▲
R314.2617.54	2,65	2,76	0,15	4,54	5,45	1,75	1,72	314041R	▲	▲
R314.3118.54	3,15	3,26	0,15	4,54	5,45	1,75	1,72	314041R	▲	▲
R314.4120.54	4,15	4,26	0,15	4,99	5,45	2	1,97	314041R	▲	▲
R314.4125.54	4,15	4,26	0,15	4,99	5,45	2,5	2,47	314041R	▲	▲
R314.5130.61	5,15	5,26	0,15	5,85	6,1	3	2,97	314052R	▲	▲
L314.1105.54	1,1	1,21	0,1	4,52	5,45	0,5	0,49	314041L		Δ
L314.1307.54	1,3	1,41	0,1	4,62	5,45	0,75	0,67	314041L		Δ
L314.1308.54	1,3	1,41	0,1	4,62	5,45	0,85	0,83	314041L		Δ
L314.1609.54	1,6	1,71	0,1	4,52	5,45	0,85	0,83	314041L	▲	▲
L314.1610.54	1,6	1,71	0,1	4,52	5,45	1	0,97	314041L		▲
L314.1812.54	1,85	1,96	0,15	4,64	5,45	1,25	1,23	314041L		▲
L314.2115.54	2,15	2,26	0,15	4,79	5,45	1,5	1,47	314041L		▲
L314.2616.54	2,65	2,76	0,15	4,54	5,45	1,5	1,47	314041L		▲
L314.2617.54	2,65	2,76	0,15	4,54	5,45	1,75	1,72	314041L		▲
L314.3118.54	3,15	3,26	0,15	4,54	5,45	1,75	1,72	314041L	Δ	
L314.4120.54	4,15	4,26	0,15	4,99	5,45	2	1,97	314041L	Δ	Δ
L314.4125.54	4,15	4,26	0,15	4,99	5,45	2,5	2,47	314041L		Δ
L314.5130.61	5,15	5,26	0,15	5,85	6,1	3	2,97	314052L		Δ

Geometrie in Abhängigkeit des Einlegewinkel λ
Geometrie depending on angle of seating λ

λ	γ	α
10°	15°	6°
14°	11°	10°

P	●	●
M	●	●
K	●	●
N	○	●
S	●	●
H	-	-

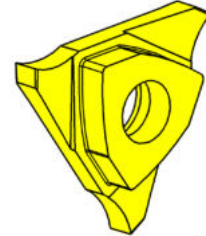
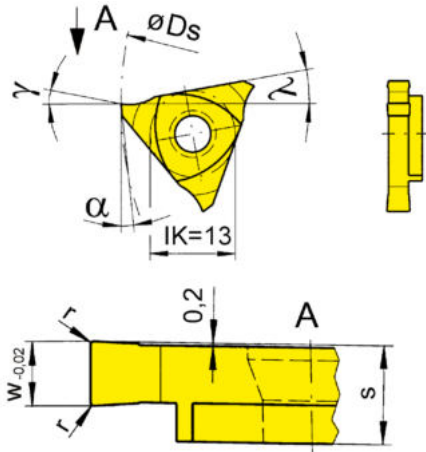
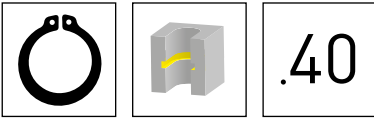

R = rechts wie gezeichnet
R = right hand version shown

L = links spiegelbildlich
L = left hand version

▲ ab Lager
on stock

HM-Sorten
Carbide grades
▲ 4 Wochen
4 weeks

Bestellnummer Part number	Nw	w	r	s	HIS	MG12	TI25	TN35
R314.0130.40	1,3	1,41	0,1	5,4	314027R	▲	▲	▲
R314.0160.40	1,6	1,71	0,1	5,4	314027R	▲	▲	▲
R314.0185.40	1,85	1,96	0,15	5,4	314027R	▲	▲	▲
R314.0215.40	2,15	2,26	0,15	5,4	314027R	▲	▲	▲
R314.0265.40	2,65	2,76	0,15	5,4	314027R	▲	▲	▲
R314.0315.40	3,15	3,26	0,15	5,4	314027R	▲	▲	▲
R314.0415.40	4,15	4,26	0,15	5,4	314041R	▲	▲	▲
R314.0515.40	5,15	5,26	0,15	5,4	314052R	▲	▲	▲
L314.0130.40	1,3	1,41	0,1	5,4	314027L	▲	▲	▲
L314.0160.40	1,6	1,71	0,1	5,4	314027L	▲	▲	▲
L314.0185.40	1,85	1,96	0,15	5,4	314027L	▲	▲	▲
L314.0215.40	2,15	2,26	0,15	5,4	314027L	▲	▲	▲
L314.0265.40	2,65	2,76	0,15	5,4	314027L	▲	▲	▲
L314.0315.40	3,15	3,26	0,15	5,4	314027L	▲	▲	▲
L314.0415.40	4,15	4,26	0,15	5,4	314041L	▲	▲	▲
L314.0515.40	5,15	5,26	0,15	5,4	314052L	▲	▲	▲

Geometrie in Abhängigkeit des Einlegewinkel λ
Geometrie depending on angle of seating λ

λ	γ	α
10°	15°	6°
14°	11°	10°

P	●	●	●
M	-	●	●
K	-	●	●
N	-	●	●
S	-	●	●
H	-	-	-



D

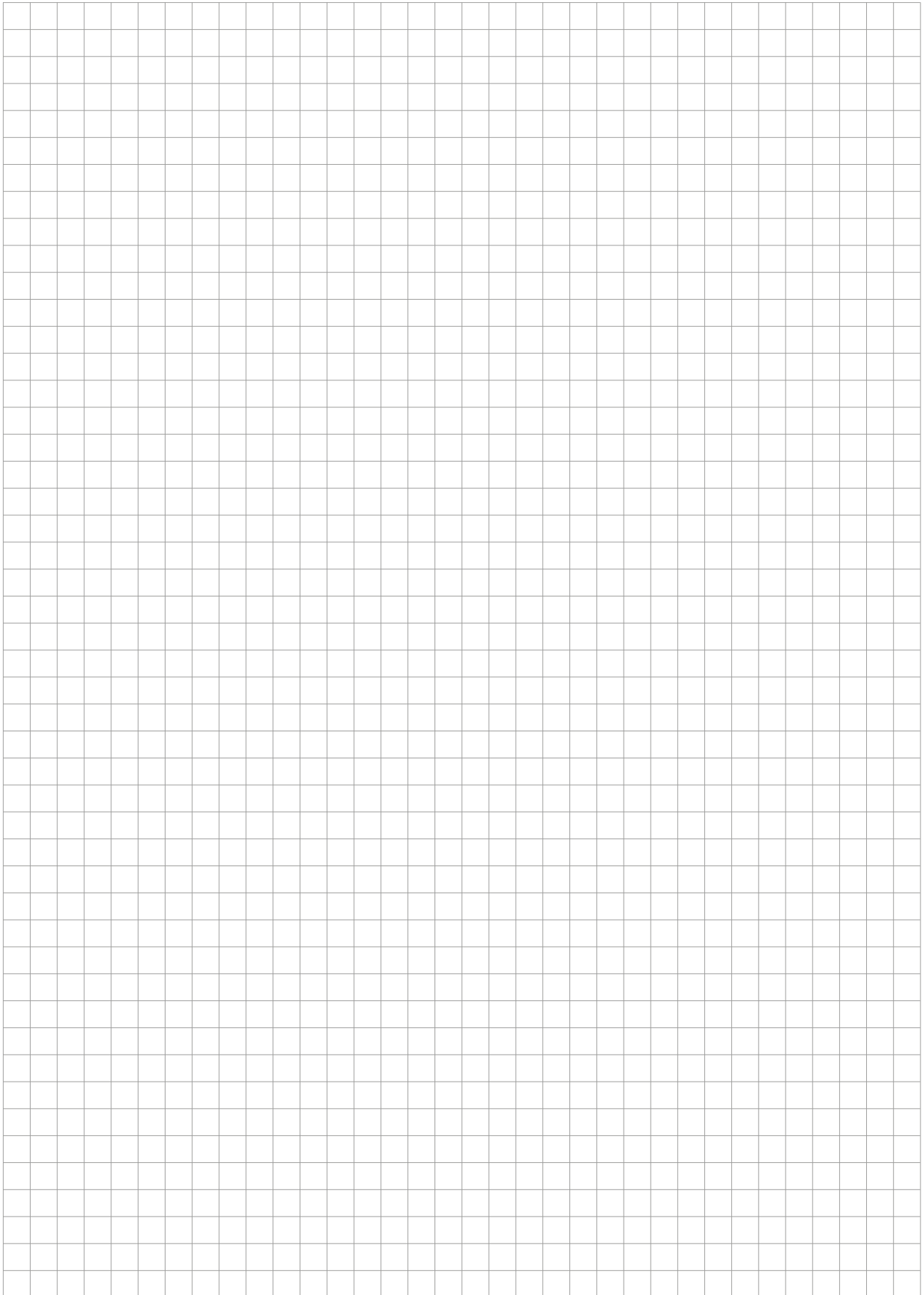

M101



E

Nutfräser

ab Schneidkreis \varnothing 63 mm
Nutbreite 1,2 - 4,6 mm

Groove milling cutter

from cutting edge \varnothing 63 mm
Width of groove 1,2 - 4,6 mm

Nutfräser
Groove milling cutter
M101

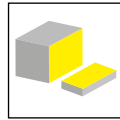

Seite/Page
235

Scheibenfräser
Disc Milling Cutter
M101

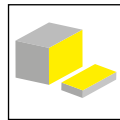

Seite/Page
236-237

Aufsteckfräser
Arbour Mounted Cutter
M101

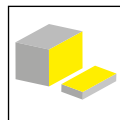

Seite/Page
238-239

Schneidplatte
Insert
S101

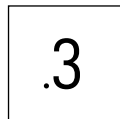

Seite/Page
240, 243

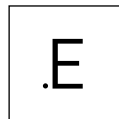

Seite/Page
241-242

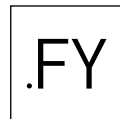

Seite/Page
244

Technische Hinweise
Technical Instructions

Seite/Page
245

E

Nutfräser

Groove milling cutter

M101



Abbildung = rechtsschneidend
Picture = right hand cutting version

Bestellnummer Part number	Z	Ds	d	l ₁	l ₂	d ₁	b	t _{max}	Form	Schneidbreite Width of groove	n _{max}	HWS
M101.063.D16.23.2.12A	5	63	16	110	30	23	0,95	19,5	A	1,2-1,2	7500	10112
M101.063.D16.23.2.14A	5	63	16	110	30	23	1,15	19,5	A	1,4-1,4	7500	10140
M101.063.D16.23.2.16A	5	63	16	110	30	23	1,3	19,5	A	1,6-1,8	7500	10116
M101.063.D16.23.2.20A	5	63	16	110,35	30,4	23	1,6	19,5	A	2,0-2,3	7500	10120
M101.063.D20.23.2.12B	5	63	20	110	30	23	0,95	19,5	B	1,2-1,2	7500	10112
M101.063.D20.23.2.14B	5	63	20	110	30	23	1,15	19,5	B	1,4-1,4	7500	10140
M101.063.D20.23.2.16B	5	63	20	110	30	23	1,3	19,5	B	1,6-1,8	7500	10116
M101.063.D20.23.2.20B	5	63	20	110,35	30,4	23	1,6	19,5	B	2,0-2,3	7500	10120
M101.063.D25.23.2.12B	5	63	25	110	30	23	0,95	19,5	B	1,2-1,2	7500	10112
M101.063.D25.23.2.16B	5	63	25	110	30	23	1,3	19,5	B	1,6-1,8	7500	10116
M101.063.D25.23.2.20B	5	63	25	110	30	23	1,6	19,5	B	2,0-2,3	7500	10120

Der Schlüssel P101.01 gehört nicht zum Lieferumfang des Fräasers. Bitte separat bestellen!
Wrench P101.01 is not combined with slotting cutter - separate order required!

Ersatzteile

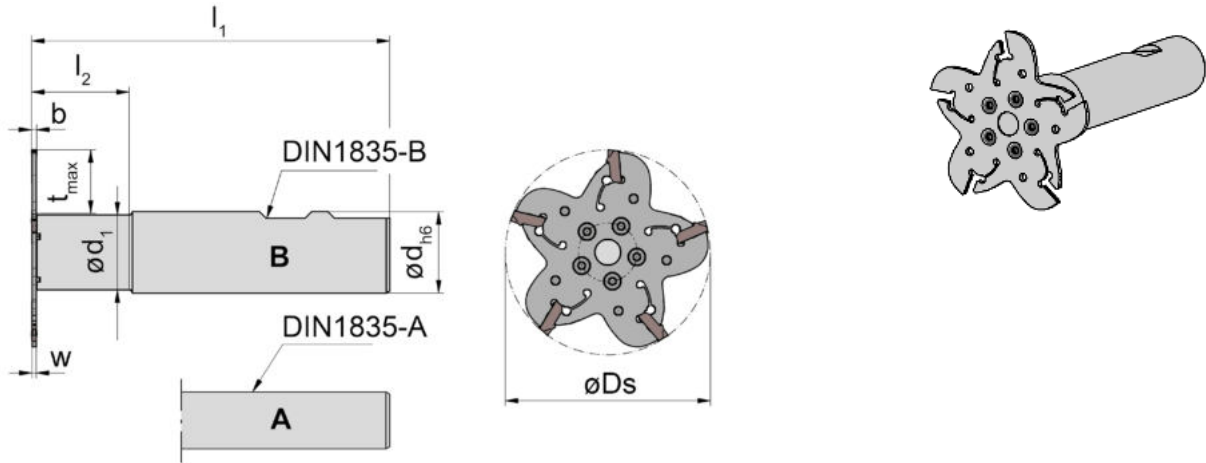
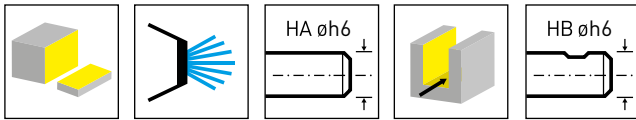
Spare Parts

Nutfräser Groove milling cutter	Schaft Shank	Stammbblatt Blade	TORX PLUS®-Schlüssel TORX PLUS® Wrench	Spannschraube Clamping Screw
M101.063.D16.23.2.12A	020.D16.23.2.12 A	M101.0063.28.23.12	T8PL	
M101.063.D16.23.2.14A	020.D16.23.2.12 A	M101.0063.28.23.14	T8PL	
M101.063.D16.23.2.16A	020.D16.23.2.16A	M101.0063.28.23.16	T8PL	
M101.063.D16.23.2.20A	020.D16.23.2.16A	M101.0063.28.23.20	T8PL	
M101.063.D20.23.2.12B	020.D20.23.2.12B	M101.0063.28.23.12	T8PL	
M101.063.D20.23.2.14B	020.D20.23.2.12B	M101.0063.28.23.14	T8PL	
M101.063.D20.23.2.16B	020.D20.23.2.16B	M101.0063.28.23.16	T8PL	
M101.063.D20.23.2.20B	020.D20.23.2.16B	M101.0063.28.23.20	T8PL	
M101.063.D25.23.2.12B	020.D25.23.2.12B	M101.0063.28.23.12	T8PL	030.3543.T8P
M101.063.D25.23.2.16B	020.D25.23.2.16B	M101.0063.28.23.16	T8PL	030.3543.T8P
M101.063.D25.23.2.20B	020.D25.23.2.20B	M101.0063.28.23.20	T8PL	030.3543.T8P



Abbildung = rechtsschneidend

Picture = right hand cutting version

Bestellnummer Part number	Z	Ds	t _{max}	b	d ₂	b ₂	d ₄	d ₆	d ₅	Schneidbreite Width of groove	n _{max}	HWS
M101.0080.22.12	7	80	20	0,95	22	13	36	4,25	29	1,2-1,2	6000	10112
M101.0080.22.14	7	80	20	1,15	22	13,1	36	4,25	29	1,4-1,4	6000	10140
M101.0080.22.16	7	80	20	1,3	22	13,3	36	4,25	29	1,6-1,8	6000	10116
M101.0100.22.16	9	100	30	1,3	22	13,3	36	4,25	29	1,6-1,8	5000	10116
M101.0125.32.16	11	125	33	1,3	32	21,3	55	6,25	45	1,6-1,8	4000	10116
M101.0080.22.20	7	80	20	1,6	22	13,6	36	4,25	29	2,0-2,3	6000	10120
M101.0100.22.20	9	100	30	1,6	22	13,6	36	4,25	29	2,0-2,3	5000	10120
M101.0125.32.20	11	125	33	1,6	32	21,6	55	6,25	45	2,0-2,3	4000	10120

Der Schlüssel **P101.01** und die **Mitnehmerringsätze** gehören nicht zum Lieferumfang des Fräasers. Bitte separat bestellen!
Wrench P101.01 and the driving collar sets are not combined with slotting cutter - separate order required!

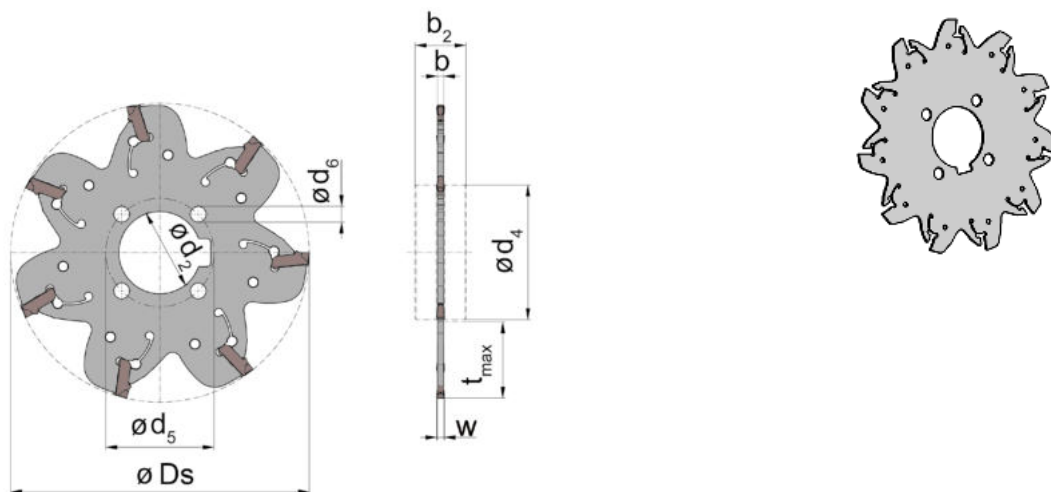
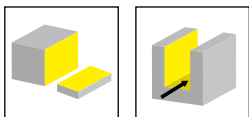
Ersatzteile

Spare Parts

Scheibenfräser Disc Milling Cutter	Mitnehmerringsatz Driving hole ringset
M101....	020.22.06.36
M101.0125.32...	020.32.10.55



Abbildung = rechtsschneidend
Picture = right hand cutting version

Bestellnummer Part number	Z	Ds	t _{max}	b	d ₂	b ₂	d ₄	d ₆	d ₅	Schneidbreite Width of groove	n _{max}	HWS
M101.0080.22.30	6	80	20	2,4	22	14,4	36	4,25	29	2,8-3,4	6000	10130
M101.0100.22.30	8	100	26	2,4	22	22,4	46	5,25	32	2,8-3,4	5000	10130
M101.0125.32.30	10	125	34	2,4	32	22,4	55	6,25	45	2,8-3,4	4000	10130
M101.0160.40.30	12	160	39	2,4	40	26,4	80	11,25	63	2,8-3,4	3000	10130
M101.0080.22.40	6	80	20	3,2	22	15,2	36	4,25	29	3,8-4,6	6000	10140
M101.0100.22.40	8	100	26	3,2	22	23,2	46	5,25	32	3,8-4,6	5000	10140
M101.0125.32.40	10	125	34	3,2	32	23,2	55	6,25	45	3,8-4,6	4000	10140
M101.0160.40.40	12	160	39	3,2	40	27,2	80	11,25	63	3,8-4,6	3000	10140
M101.0200.40.40	16	200	59	3,2	40	27,2	80	11,25	63	3,8-4,6	2500	10140

Der Schlüssel **P101.02** und die **Mitnehmerringsätze** gehören nicht zum Lieferumfang des Fräasers. Bitte separat bestellen!
Wrench P101.02 and the driving collar sets are not combined with slotting cutter - separate order required!

Ersatzteile

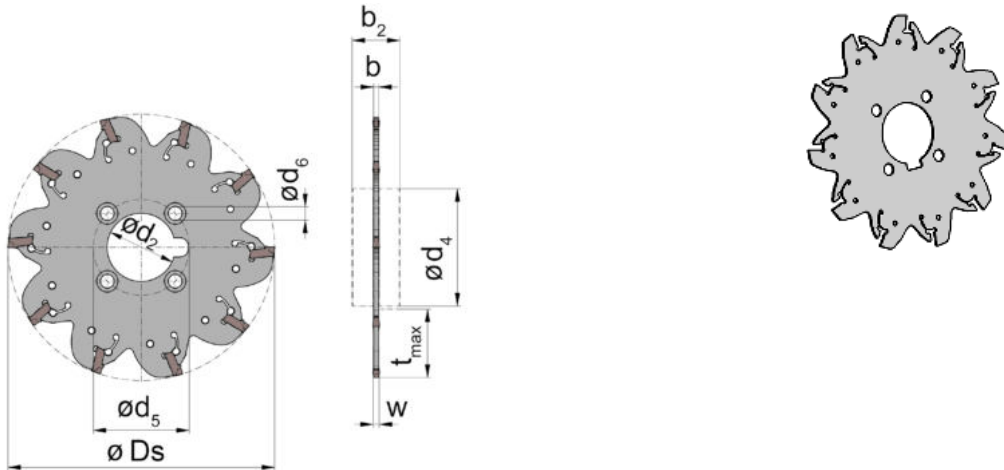
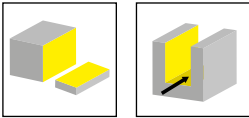
Spare Parts

Scheibenfräser Disc Milling Cutter	Mitnehmerringsatz Driving hole ringset
M101...	020.22.06.36
M101.0125.32...	020.32.10.55





Abbildung = rechtsschneidend
Picture = right hand cutting version

Bestellnummer Part number	Z	Ds	t _{max}	h	b	d ₁	d ₄	l ₁	l ₂	s	P	d ₂	d ₃	n _{max}	Schneidbreite Width of groove	HWS
M101.0080.A16.12	7	80	20	33	0,95	13,5	32	18	22,7	8,4	5,6	37	16	6000	1,2-1,2	10112
M101.0080.A16.14	7	80	20	33,2	1,15	13,5	32	18	22,7	8,4	5,6	37	16	6000	1,4-1,4	10140
M101.0080.A16.16	7	80	20	33	1,3	13,5	32	18	22,7	8,4	5,6	37	16	6000	1,6-1,8	10116
M101.0100.A22.16	9	100	28	37	1,3	18,5	40,5	20	24,7	10,4	6,3	40,5	22	5000	1,6-1,8	10116
M101.0125.A32.16	11	125	34	50	1,3	28,5	45	25	36,7	14,4	8	55	32	4000	1,6-1,8	10116
M101.0080.A16.20	7	80	20	33	1,6	13,5	32	18	22,7	8,4	5,6	37	16	6000	2,0-2,3	10120
M101.0100.A22.20	9	100	28	37	1,6	18,5	40,5	20	24,7	10,4	6,3	40,5	22	5000	2,0-2,3	10120
M101.0125.A32.20	11	125	34	50	1,6	28,5	45	25	36,7	14,4	8	55	32	4000	2,0-2,3	10120

Der Schlüssel **P101.01** gehört nicht zum Lieferumfang des Fräasers. Bitte separat bestellen!
Wrench P101.01 is not combined with slotting cutter - separate order required!

Ersatzteile

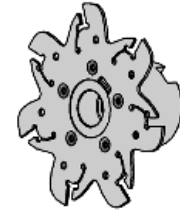
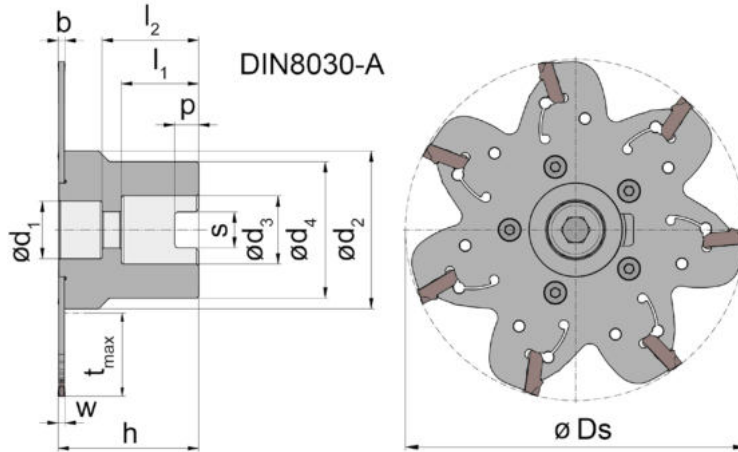
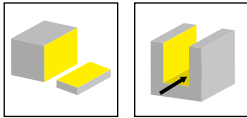
Spare Parts

Aufsteckfräser Arbour Mounted Cutter	Spannschraube Clamping Screw	Stammblatt Blade	TORX PLUS®-Schlüssel TORX PLUS® Wrench
M101.0080.A16.12	030.3543.T8P	M101.0080.28.12	T8PL
M101.0080.A16.14	030.3543.T8P	M101.0080.28.14	T8PL
M101.0080.A16.16	030.3543.T8P	M101.0080.28.16	T8PL
M101.0100.A22.16	030.3543.T8P	M101.0100.28.16	T8PL
M101.0125.A32.16	030.3543.T8P	M101.0125.28.16	T8PL
M101.0080.A16.20	030.3543.T8P	M101.0080.28.20	T8PL
M101.0100.A22.20	030.3543.T8P	M101.0100.28.20	T8PL
M101.0125.A32.20	030.3543.T8P	M101.0125.28.20	T8PL



Abbildung = rechtsschneidend
Picture = right hand cutting version

Bestellnummer Part number	Z	Ds	t _{max}	h	b	d ₁	l ₁	l ₂	s	P	d ₂	d ₃	n _{max}	Schneidbreite Width of groove	HWS
M101.0080.A22.30	6	80	19	37	2,4	18,5	20	24,7	10,4	6,3	22	22	5000	2,8-3,4	10130
M101.0100.A22.30	8	100	29	37	2,4	18,5	20	24,7	10,4	6,3	40	22	5000	2,8-3,4	10130
M101.0125.A32.30	10	125	34	50	2,4	28,5	25	36,7	14,4	8	55	32	4000	2,8-3,4	10130
M101.0160.A40.30	12	160	39	50	2,4	34,5	28	35	16,4	9	80	40	3000	2,8-3,4	10130
M101.0080.A22.40	6	80	19	37,9	3,2	18,5	20	24,7	10,4	6,3	22	22	5000	3,8-4,6	10140
M101.0100.A22.40	8	100	29	37,9	3,2	18,5	20	24,7	10,4	6,3	40	22	5000	3,8-4,6	10140
M101.0125.A32.40	10	125	34	50,9	3,2	28,5	25	36,7	14,4	8	55	32	4000	3,8-4,6	10140
M101.0160.A40.40	12	160	39	50,9	3,2	34,5	28	35	16,4	9	80	40	3000	3,8-4,6	10140
M101.0200.A40.40	16	200	59	50,9	3,2	34,5	28	35	16,4	9	80	40	2500	3,8-4,6	10140

Der Schlüssel P101.02 gehört nicht zum Lieferumfang des Fräasers. Bitte separat bestellen!
Wrench P101.02 is not combined with slotting cutter - separate order required!

Ersatzteile

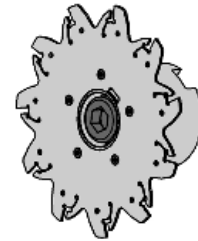
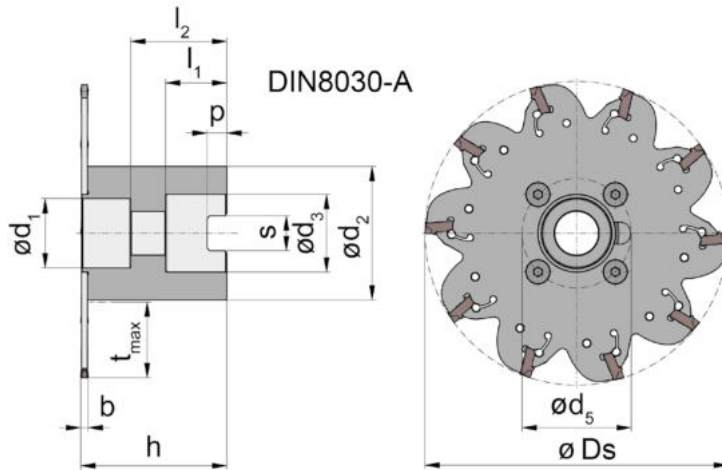
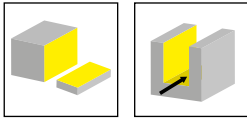
Spare Parts

Aufsteckfräser Arbour Mounted Cutter	Spannschraube Clamping Screw	Stammblatt Blade	TORX PLUS®-Schlüssel TORX PLUS® Wrench
M101.0080.A22.30	030.3543.T8P	M101.0080.28.30	T15PQ
M101.0100.A22...	030.3543.T8P		T15PQ
M101.0125.A32...	030.3543.T8P		T20PQ
M101....	030.3543.T8P		
M101.0080.A22.40		M101.0080.28.40	T15PQ

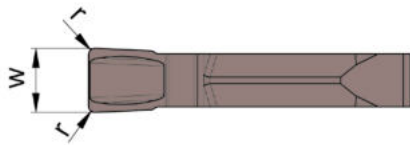
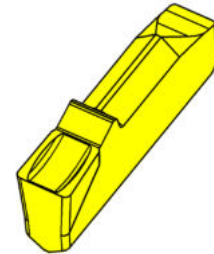
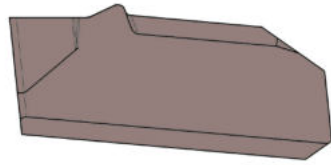
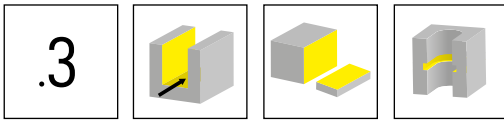

E

HM-Sorten
Carbide grades

▲ ab Lager
on stock

Δ 4 Wochen
4 weeks

Bestellnummer Part number	w	r	HIS	AS45	IG35
S101.0120.315	1,2	0,15	10112	▲	▲
S101.0140.315	1,4	0,15	10140	▲	▲
S101.0160.315	1,6	0,15	10116	▲	▲
S101.0200.320	2	0,2	10120	▲	▲
S101.0250.320	2,5	0,2	10125	Δ	Δ
				P ● -	
				M ● ●	
				K ● -	
				N ○ -	
				S ● ●	
				H - -	

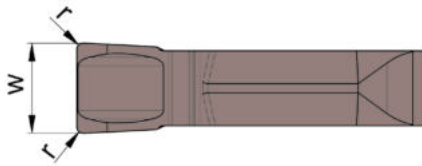
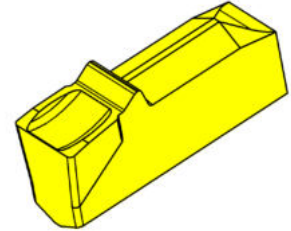
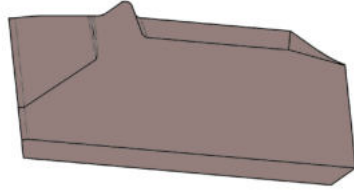
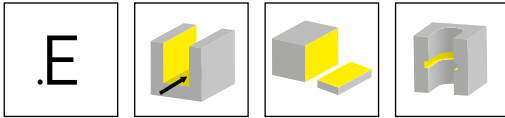

HM-Sorten
Carbide grades

▲ ab Lager
on stock

△ 4 Wochen
4 weeks

Bestellnummer Part number	w	r	HIS	AS45
S101.0300.E32	3	0,2	10130	▲
S101.0400.E33	4	0,3	10140	▲
				P ●
				M ●
				K ●
				N ○
				S ●
				H -

E

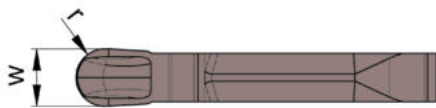
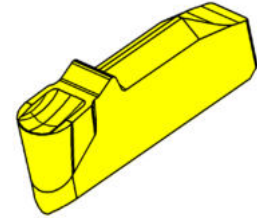
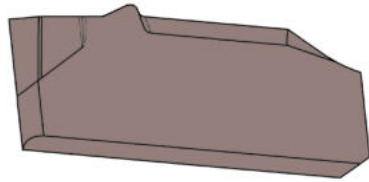
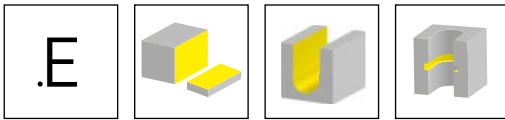

E

HM-Sorten
Carbide grades

▲ ab Lager
on stock

△ 4 Wochen
4 weeks

Bestellnummer Part number	w	r	HIS	AS45
S101.0160.E3.R08	1,6	0,8	10116	▲
S101.0200.E3.R10	2	1	10120	▲
S101.0300.E3.R15	3	1,5	10130	▲
				P ●
				M ●
				K ●
				N ○
				S ●
				H -

.3

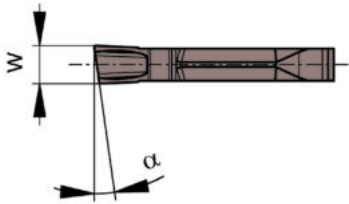
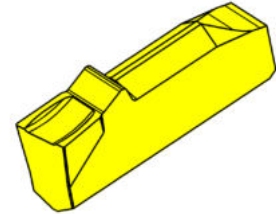
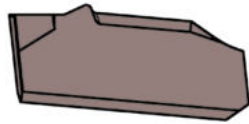
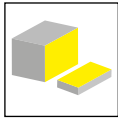

R = rechts wie gezeichnet
R = right hand version shown

L = links spiegelbildlich
L = left hand version

▲ ab Lager
on stock

HM-Sorten
Carbide grades
Δ 4 Wochen
4 weeks

Bestellnummer Part number	w	α	HIS	AS45	EG55	IG35
RS101.0812.30	1,2	8°	10112		▲	▲
RS101.0816.30	1,6	8°	10116	▲		▲
RS101.0820.30	2	8°	10120	▲		▲
RS101.0825.30	2,5	8°	10125	▲		▲
LS101.0812.30	1,2	8°	10112		▲	▲
LS101.0816.30	1,6	8°	10116	▲		▲
LS101.0820.30	2	8°	10120	▲		▲
LS101.0825.30	2,5	8°	10125	▲		▲
P	●	●	-			
M	●	○	●			
K	●	○	-			
N	○	-	-			
S	●	-	●			
H	-	-	-			

E

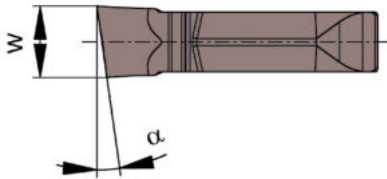
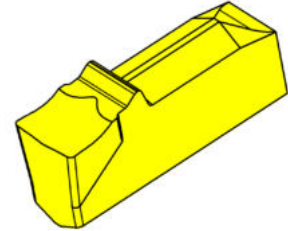
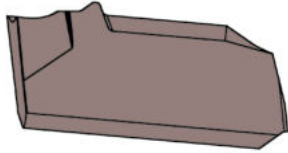
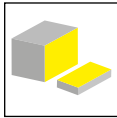

E

R = rechts wie gezeichnet
R = right hand version shown

L = links spiegelbildlich
L = left hand version

▲ ab Lager
on stock

HM-Sorten
Carbide grades
Δ 4 Wochen
4 weeks

Bestellnummer Part number	w	α	HIS	AS45	IG35
RS101.0830.FY0	3	8°	10130	▲	▲
LS101.0830.FY0	3	8°	10130	▲	▲
P	●	-			
M	●	●			
K	●	-			
N	○	-			
S	●	●			
H	-	-			

Spannsituation Schlüssel P101.01
 Setting position clamping wrench P101.01

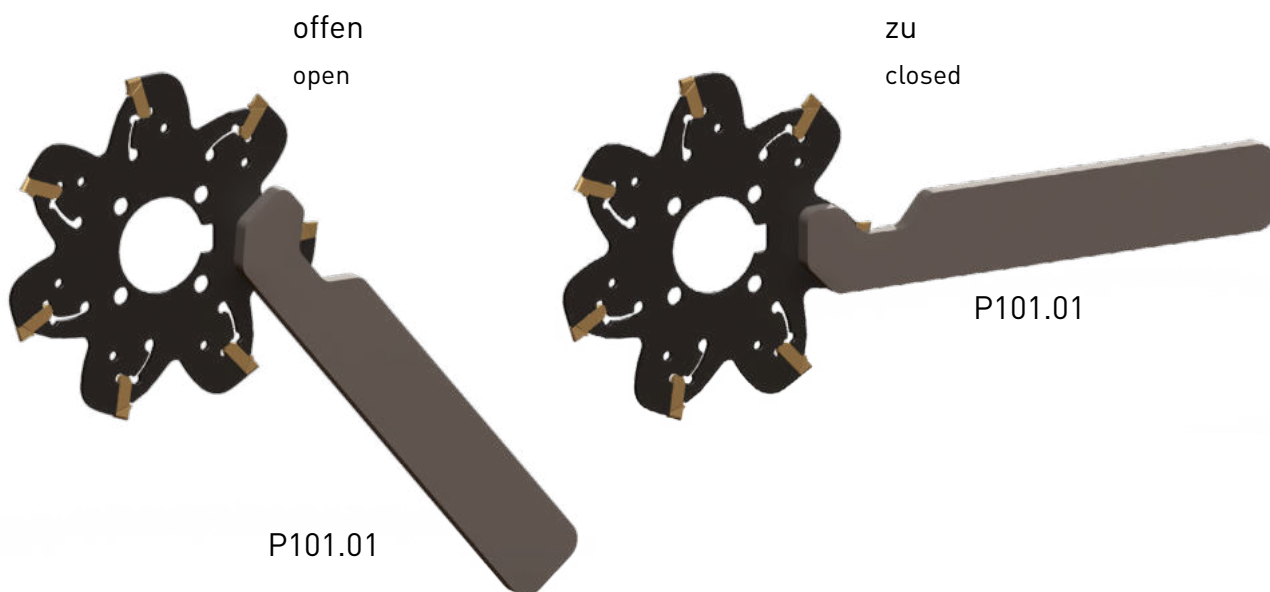

Nach Möglichkeit nur Gegenlaufräsen um Späneklemmer zu vermeiden.
 Nach dem Wechseln der Platten, Vorschub bis zum Erreichen einer Anschnitttiefe von 0,5 - 1 mm um 50% reduzieren

Use only conventional milling to avoid chip jamming.
 After changing inserts, reduce the feed rate by 50% until an initial depth of cut of 0.5 - 1 mm is reached

Maximale Drehzahlen beachten!

Please note the max. revolutions!

Ø Scheibenfräser Ø Disc milling cutter	max. Drehzahl n_{max} max. Revolutions n_{max}
Ø 63 mm	7.500 min ⁻¹
Ø 80 mm	6.000 min ⁻¹
Ø 100 mm	5.000 min ⁻¹
Ø 125 mm	4.000 min ⁻¹
Ø 160 mm	3.000 min ⁻¹
Ø 200 mm	2.500 min ⁻¹

E

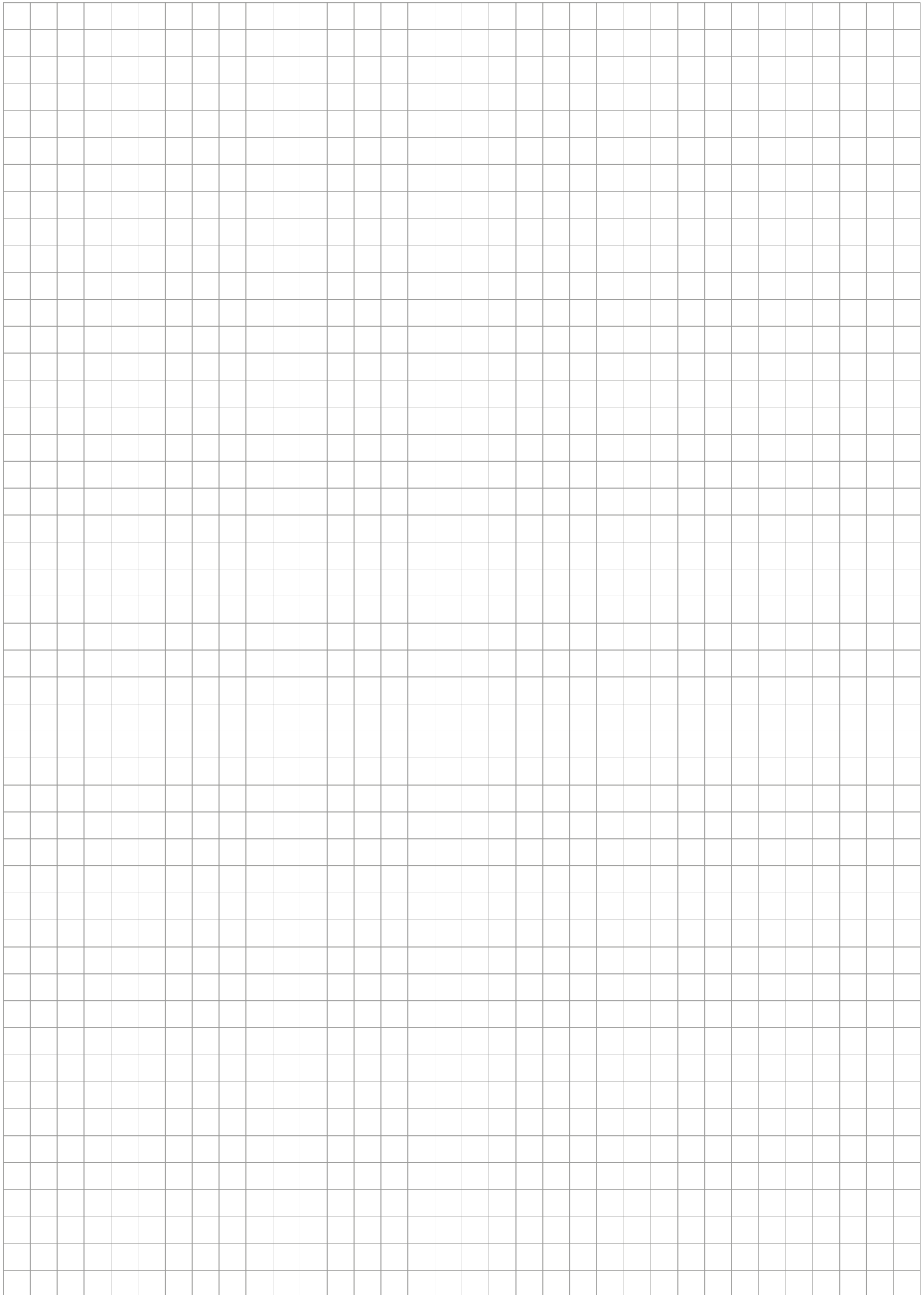



F

System/System

Seite/Page

382/383

248

M310

262

Scheibenfräser
Disc Milling Cutter
382

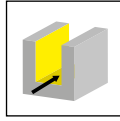

Seite/Page
250-253

Aufsteckfräser
Arbor Mounted Cutter
383

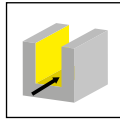

Seite/Page
254-256

Wendeschneidplatte
Indexable insert
314

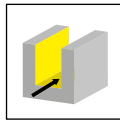

Seite/Page
257



Seite/Page
258-260

F

382/383



F

Scheibenfräser
Aufsteckfräser

Nutbreite 6 - 10 mm
Schneidkreis-Ø 80 - 200 mm

Disc Milling Cutter
Arbor Mounted Cutter

Width of groove 6 - 10 mm
Cutting edge Ø 80 - 200 mm



Abbildung = rechtsschneidend
Picture = right hand cutting version

F

Bestellnummer Part number	Z	Ds	t _{max}	d ₂	b ₂	d ₃	w	rechte WSP right hand insert	linke WSP left hand insert	HWS
382.0080.27.06	8	80	21	27	10	36	6	4x R314....	4x L314...	314027R • 314027L
382.0080.27.08	8	80	21	27	12	36	8	4x R314....	4x L314...	314041R • 314041L
382.0080.27.10	8	80	21	27	12	36	10	4x R314....	4x L314...	314052R • 314052L

Bohrung (d₂) mit Längsnut nach DIN 138
Bore (d₂) with longitudinal keyway to DIN 138

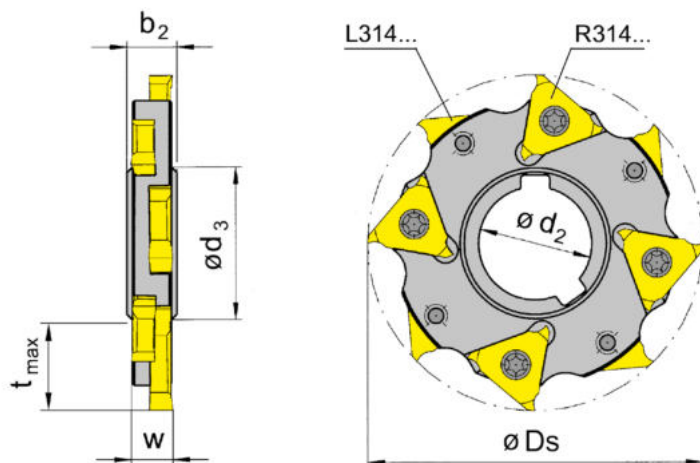
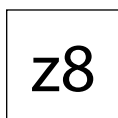
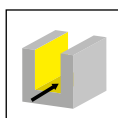
Ersatzteile

Spare Parts

Scheibenfräser Disc Milling Cutter	Spannschraube Clamping Screw	TORX PLUS®-Schlüssel TORX PLUS® Wrench
382.0080.27.06	5F.06T15P	T15PQ
382.0080.27.08	5F.08T20P	T20PQ
382.0080.27.10	5.10T20P	T20PQ

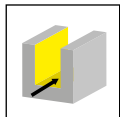

z10



Abbildung = rechtsschneidend
Picture = right hand cutting version

Bestellnummer Part number	Z	Ds	t _{max}	d ₂	b ₂	d ₃	w	rechte WSP right hand insert	linke WSP left hand insert	HWS
382.0100.32.06	10	100	25,5	32	10	47	6	5x R314...	5x L314...	314027R • 314027L
382.0100.32.08	10	100	25,5	32	12	47	8	5x R314...	5x L314...	314041R • 314041L
382.0100.32.10	10	100	25,5	32	12	47	10	5x R314...	5x L314...	314052R • 314052L

Bohrung (d2) mit Längsnut nach DIN 138
Bore (d2) with longitudinal keyway to DIN 138

Ersatzteile

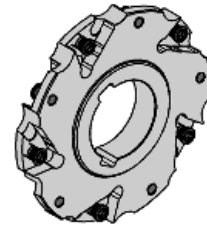
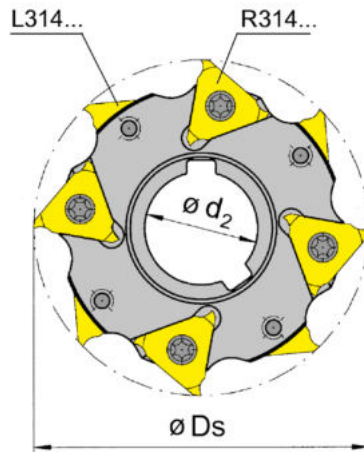
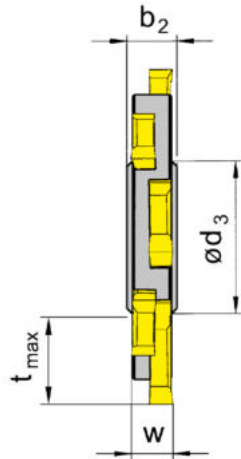
Spare Parts

Scheibenfräser Disc Milling Cutter	Spannschraube Clamping Screw	TORX PLUS®-Schlüssel TORX PLUS® Wrench
382.0100.32.06	5F.06T15P	T15PQ
382.0100.32.08	5F.08T20P	T20PQ
382.0100.32.10	5.10T20P	T20PQ





Abbildung = rechtsschneidend
Picture = right hand cutting version

F

Bestellnummer Part number	Z	Ds	t _{max}	d ₂	b ₂	d ₃	w	rechte WSP right hand insert	linke WSP left hand insert	HWS
382.0125.40.06	12	125	32,5	40	10	58	6	6x R314...	6x L314...	314027R • 314027L
382.0125.40.08	12	125	32,5	40	12	58	8	6x R314...	6x L314...	314041R • 314041L
382.0125.40.10	12	125	32,5	40	14	58	10	6x R314...	6x L314...	314052R • 314052L
382.0160.40.06	16	160	50	40	10	58	6	8x R314...	8x L314...	314027R • 314027L
382.0160.40.08	16	160	50	40	12	58	8	8x R314...	8x L314...	314041R • 314041L
382.0160.40.10	16	160	50	40	14	58	10	8x R314...	8x L314...	314052R • 314052L
382.0160.40.12	15	160	50	40	14	58	12	2x5 R314...	5x L314...	314052R • 314052L

Bohrung (d2) mit Längsnut nach DIN 138
Bore (d2) with longitudinal keyway to DIN 138

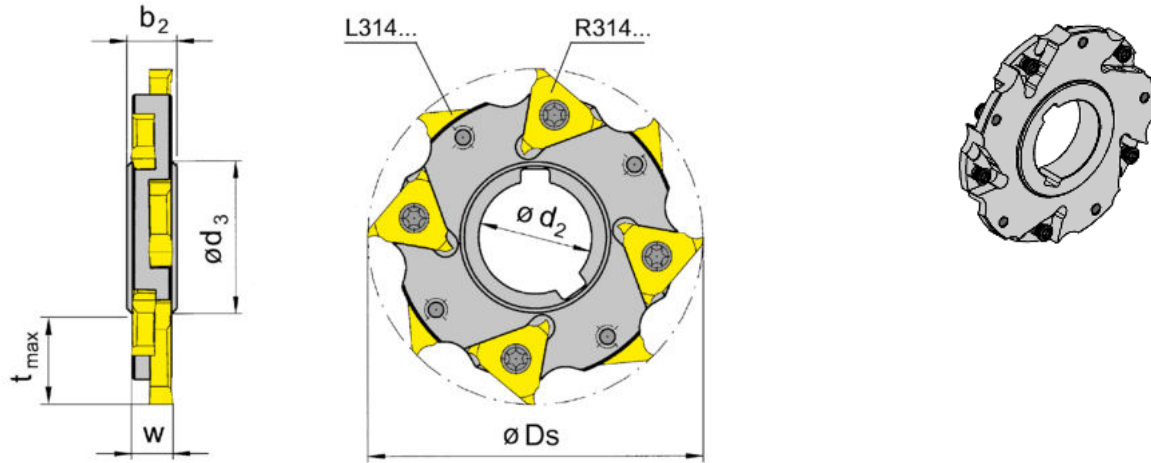
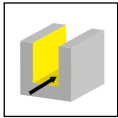
Ersatzteile

Spare Parts

Scheibenfräser Disc Milling Cutter	Spannschraube Clamping Screw	TORX PLUS®-Schlüssel TORX PLUS® Wrench
382...06	5F.06T15P	T15PQ
382...08	5F.08T20P	T20PQ
382...10/12	5.10T20P	T20PQ

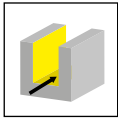

z18



Abbildung = rechtsschneidend
Picture = right hand cutting version

Bestellnummer Part number	Z	Ds	t _{max}	d ₂	b ₂	d ₃	w	rechte WSP right hand insert	linke WSP left hand insert	HWS
382.0200.50.06	18	200	63,5	50	10	71	6	9x R314...	9x L314...	314027R • 314027L
382.0200.50.08	18	200	63,5	50	12	71	8	9x R314...	9x L314...	314041R • 314041L
382.0200.50.10	18	200	63,5	50	14	71	10	9x R314...	9x L314...	314052R • 314052L
382.0200.50.12	18	200	63,5	50	14	71	12	2x6 R314...	6x L314...	314052R • 314052L
382.0200.50.14	18	200	63,5	50	16	71	14	2x6 R314...	6x L314...	314052R • 314052L

Bohrung (d2) mit Längsnut nach DIN 138
Bore (d2) with longitudinal keyway to DIN 138

Ersatzteile
Spare Parts

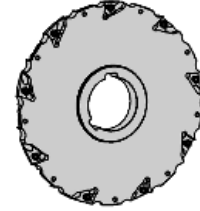
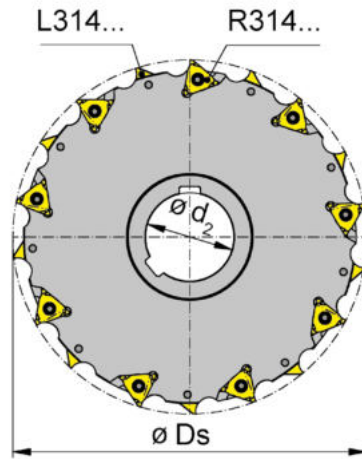
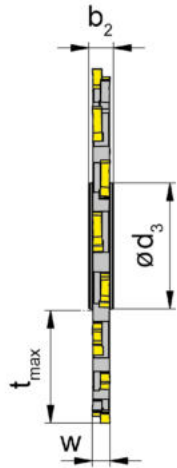
Scheibenfräser Disc Milling Cutter	Spannschraube Clamping Screw	TORX PLUS®-Schlüssel TORX PLUS® Wrench
382.0200.50.06	5F.06T15P	T15PQ
382.0200.50.08	5F.08T20P	T20PQ
382.0200.50....	5.10T20P	T20PQ



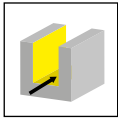

z10



Abbildung = rechtsschneidend
Picture = right hand cutting version

F

Bestellnummer Part number	Z	Ds	t _{max}	h	d ₂	d ₃	w	rechte WSP right hand insert	linke WSP left hand insert	HWS
383.0100.27.06	10	100	25	50	48	27	6	5x R314...	5x L314...	314027R • 314027L
383.0100.27.08	10	100	25	50	48	27	8	5x R314...	5x L314...	314041R • 314041L
383.0100.27.10	10	100	25	50	48	27	10	5x R314...	5x L314...	314052R • 314052L

Bohrung (d3) mit Quernut nach DIN 138
Bore (d3) with cross keyway to DIN 138

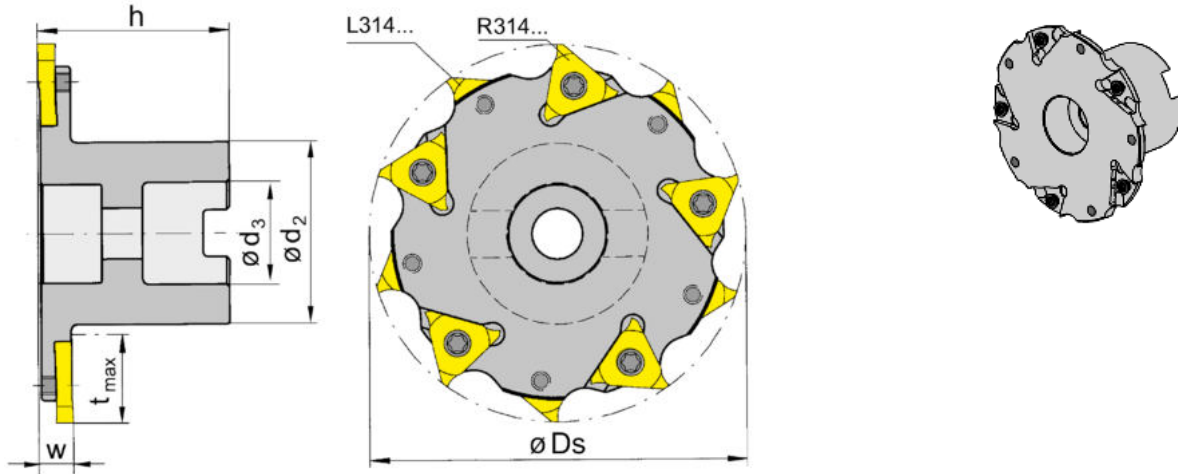
Ersatzteile
Spare Parts

Aufsteckfräser Arbor Mounted Cutter	Spannschraube Clamping Screw	TORX PLUS®-Schlüssel TORX PLUS® Wrench
383.0100.27.06	5F.06T15P	T15PQ
383.0100.27.08	5F.08T20P	T20PQ
383.0100.27.10	5.10T20P	T20PQ

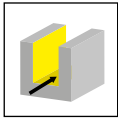

z12



Abbildung = rechtsschneidend
Picture = right hand cutting version

Bestellnummer Part number	Z	Ds	t _{max}	h	d ₂	d ₃	w	rechte WSP right hand insert	linke WSP left hand insert	HWS
383.0125.32.06	12	125	32	50	56	32	6	6x R314...	6x L314...	314027R • 314027L
383.0125.32.08	12	125	32	50	56	32	8	6x R314...	6x L314...	314041R • 314041L

Bohrung (d3) mit Quernut nach DIN 138
Bore (d3) with cross keyway to DIN 138

Ersatzteile
Spare Parts

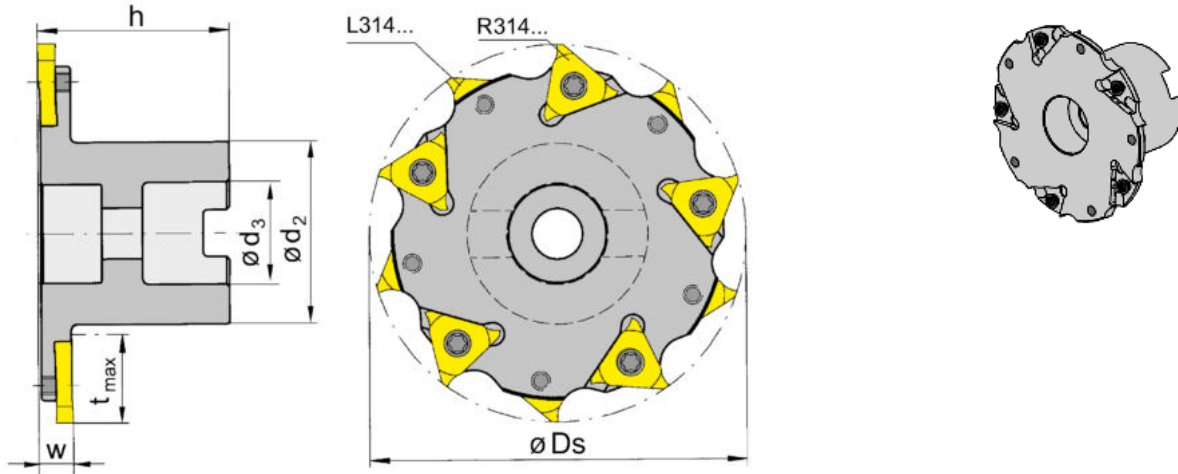
Aufsteckfräser Arbor Mounted Cutter	Spannschraube Clamping Screw	TORX PLUS®-Schlüssel TORX PLUS® Wrench
383.0125.32.06	5F.06T15P	T15PQ
383.0125.32.08	5F.08T20P	T20PQ





Abbildung = rechtsschneidend
Picture = right hand cutting version

F

Bestellnummer Part number	Z	Ds	t _{max}	h	d ₂	d ₃	w	rechte WSP right hand insert	linke WSP left hand insert	HWS
383.0160.40.06	16	160	44	60	70	40	6	8x R314...	8x L314...	314027R • 314027L
383.0160.40.08	16	160	44	60	70	40	8	8x R314...	8x L314...	314041R • 314041L
383.0200.40.06	18	200	54	50	90	40	6	9x R314...	9x L314...	314027R • 314027L
383.0200.40.08	18	200	54	50	90	40	8	9x R314...	9x L314...	314041R • 314041L
383.0200.40.10	18	200	54	50	90	40	10	9x R314...	9x L314...	314052R • 314052L
383.0200.40.12	18	200	54	50	90	40	12	2x6 R314...	6x L314...	314052R • 314052L

Bohrung (d3) mit Quernut nach DIN 138
Bore (d3) with cross keyway to DIN 138

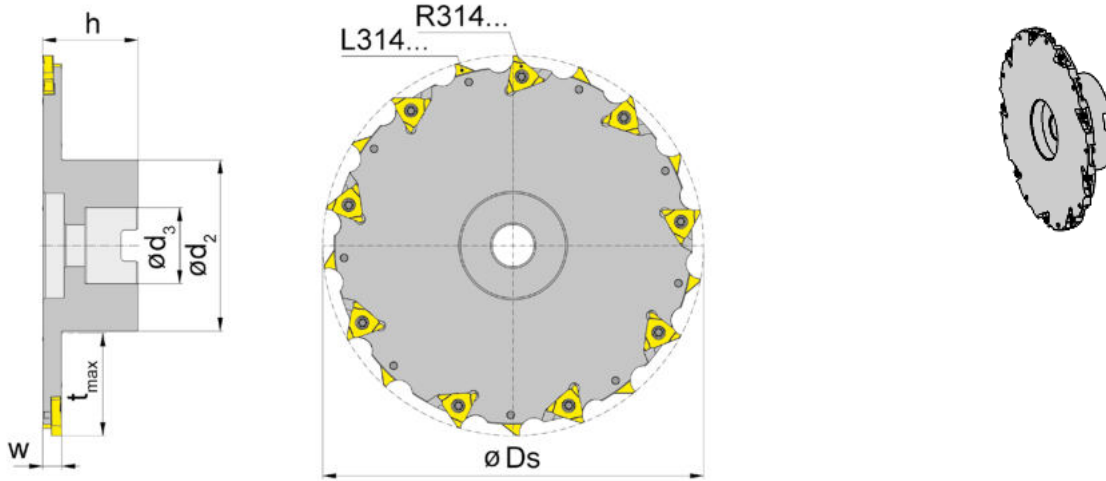
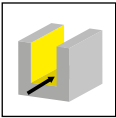
Ersatzteile

Spare Parts

Aufsteckfräser Arbor Mounted Cutter	Spannschraube Clamping Screw	TORX PLUS®-Schlüssel TORX PLUS® Wrench
383.0160..06	5F.06T15P	T15PQ
383.0160..08	5F.08T20P	T20PQ
383.0200...	5.10T20P	T20PQ

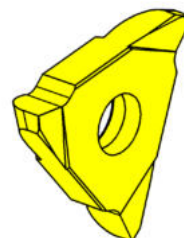
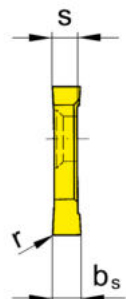
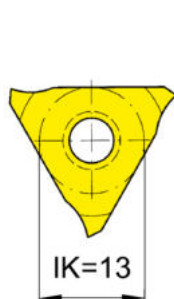
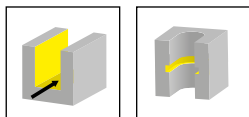

R = rechts wie gezeichnet
R = right hand version shown

L = links spiegelbildlich
L = left hand version

▲ ab Lager
on stock

HM-Sorten
Carbide grades
Δ 4 Wochen
4 weeks

Bestellnummer Part number	w	b _s	r	s	HIS	AS45	TI25	TN35
R314.6032.00	6	3,2	0,2	2,7	314052R	▲	▲	▲
R314.8043.00	8	4,3	0,2	4,1	314052R	▲	▲	▲
R314.0054.00	14	5,4	0,2	5,2	314052R	▲	▲	▲
L314.6032.00	6	3,2	0,2	2,7	314052L	▲	▲	▲
L314.8043.00	8	4,3	0,2	4,1	314052L	▲	▲	▲
L314.0054.00	14	5,4	0,2	5,2	314052L	▲	▲	▲
N314.0056.00	-	5,6	0,2	5,2	314052N	▲	▲	▲
Hinweis:						P	•	•
Standard-WSP N314.0056.00 für Verwendung in Sonderbauförmern.						M	•	•
Note:						K	•	•
Standard insert N314.0056.00 for use with special cutters.						N	o	•
						S	•	•
						H	-	-



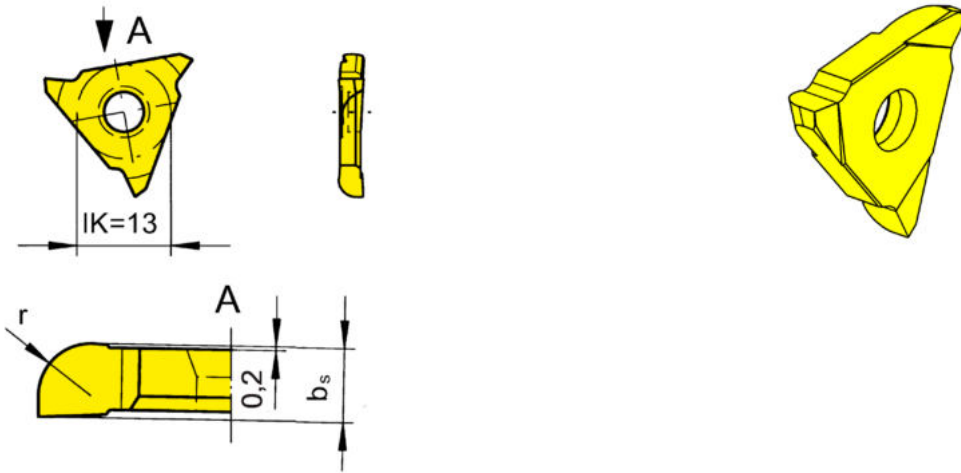
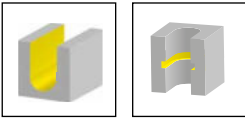

R = rechts wie gezeichnet
R = right hand version shown

L = links spiegelbildlich
L = left hand version

▲ ab Lager
on stock

HM-Sorten
Carbide grades
Δ 4 Wochen
4 weeks

F

Bestellnummer Part number	w	b _s	r	HIS	AS45	TI25
R314.0320.20	6	3,2	2	314027R	▲	▲
R314.0430.20	8	4,3	2	314041R	▲	▲
R314.0430.25	8	4,3	2,5	314041R	▲	▲
R314.0540.20	10	5,43	2	314052R	▲	▲
R314.0540.25	10	5,44	2,5	314052R	▲	▲
R314.0540.40	10	5,47	4	314052R	▲	▲
L314.0320.20	6	3,2	2	314027L	▲	▲
L314.0430.20	8	4,3	2	314041L	▲	▲
L314.0430.25	8	4,3	2,5	314041L	▲	▲
L314.0540.20	10	5,43	2	314052L	▲	▲
L314.0540.25	10	5,44	2,5	314052L	▲	▲
L314.0540.40	10	5,47	4	314052L	▲	▲
					P ● ●	
					M ● ●	
					K ● ●	
					N ○ ●	
					S ● ●	
					H - -	

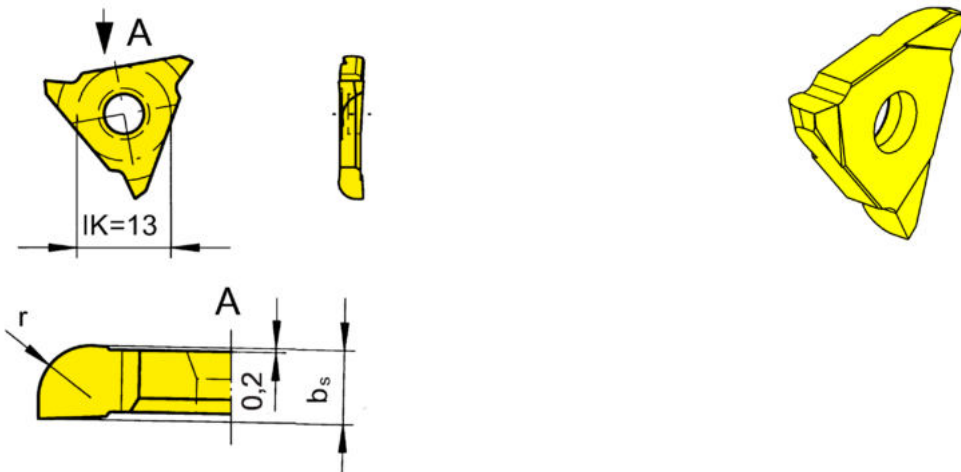
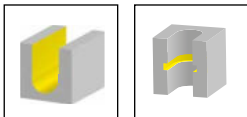

R = rechts wie gezeichnet
R = right hand version shown

L = links spiegelbildlich
L = left hand version

▲ ab Lager
on stock

HM-Sorten
Carbide grades
Δ 4 Wochen
4 weeks

Bestellnummer Part number	w	b _s	r	HIS	AS45	TI25
R314.0320.04	6	3,2	0,4	314027R	Δ	
R314.0320.05	6	3,2	0,5	314027R	▲	
R314.0320.10	6	3,2	1	314027R	Δ	
R314.0320.15	6	3,2	1,5	314027R	▲	
R314.0320.16	6	3,2	1,6	314027R	Δ	
R314.0320.20	6	3,2	2	314027R	▲	▲
R314.0430.04	8	4,3	0,4	314041R	Δ	
R314.0430.05	8	4,3	0,5	314041R	Δ	
R314.0430.10	8	4,3	1	314041R	▲	
R314.0430.15	8	4,3	1,5	314041R	▲	
R314.0430.16	8	4,3	1,6	314041R	Δ	
R314.0430.20	8	4,3	2	314041R	▲	▲
R314.0430.25	8	4,3	2,5	314041R	▲	▲
L314.0320.04	6	3,2	0,4	314027L	Δ	
L314.0320.05	6	3,2	0,5	314027L	▲	
L314.0320.10	6	3,2	1	314027L	Δ	
L314.0320.15	6	3,2	1,5	314027L	▲	
L314.0320.16	6	3,2	1,6	314027L	Δ	
L314.0320.20	6	3,2	2	314027L	▲	▲
L314.0430.04	8	4,3	0,4	314041L	Δ	
L314.0430.05	8	4,3	0,5	314041L	Δ	
L314.0430.10	8	4,3	1	314041L	▲	
L314.0430.15	8	4,3	1,5	314041L	▲	
L314.0430.16	8	4,3	1,6	314041L	Δ	
L314.0430.20	8	4,3	2	314041L	▲	▲
L314.0430.25	8	4,3	2,5	314041L	▲	▲
P	•	•				
M	•	•				
K	•	•				
N	o	•				
S	•	•				
H	-	-				



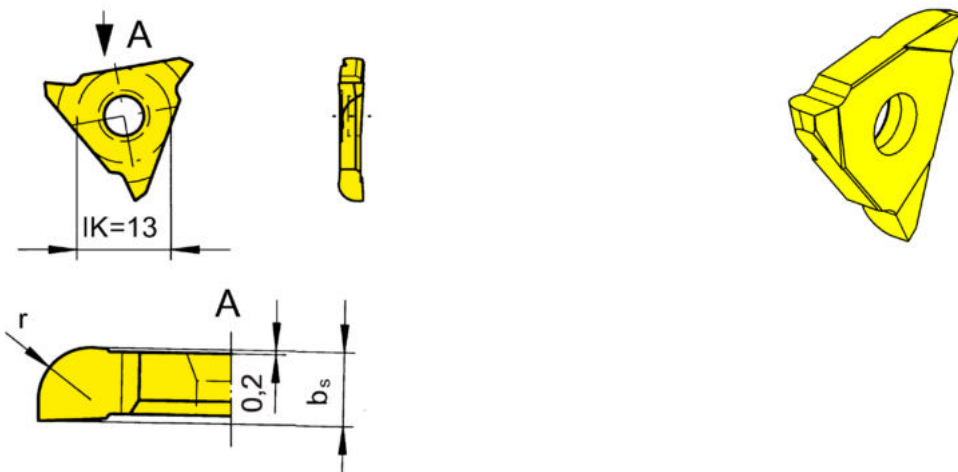
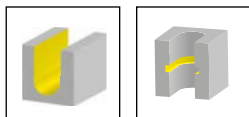

R = rechts wie gezeichnet
R = right hand version shown

L = links spiegelbildlich
L = left hand version

▲ ab Lager
on stock

HM-Sorten
Carbide grades
Δ 4 Wochen
4 weeks

F

Bestellnummer Part number	w	b _s	r	HIS	AS45	TI25
R314.0540.04	10	5,43	0,4	314052R	Δ	
R314.0540.05	10	5,43	0,5	314052R	Δ	
R314.0540.10	10	5,43	1	314052R	Δ	
R314.0540.15	10	5,43	1,5	314052R	Δ	
R314.0540.16	10	5,43	1,6	314052R	Δ	
R314.0540.20	10	5,43	2	314052R	▲	▲
L314.0540.04	10	5,43	0,4	314052L	Δ	
L314.0540.05	10	5,43	0,5	314052L	Δ	
L314.0540.10	10	5,43	1	314052L	Δ	
L314.0540.15	10	5,43	1,5	314052L	Δ	
L314.0540.16	10	5,43	1,6	314052L	Δ	
L314.0540.20	10	5,43	2	314052L	▲	▲
					P ● ●	
					M ● ●	
					K ● ●	
					N ○ ●	
					S ● ●	
					H - -	

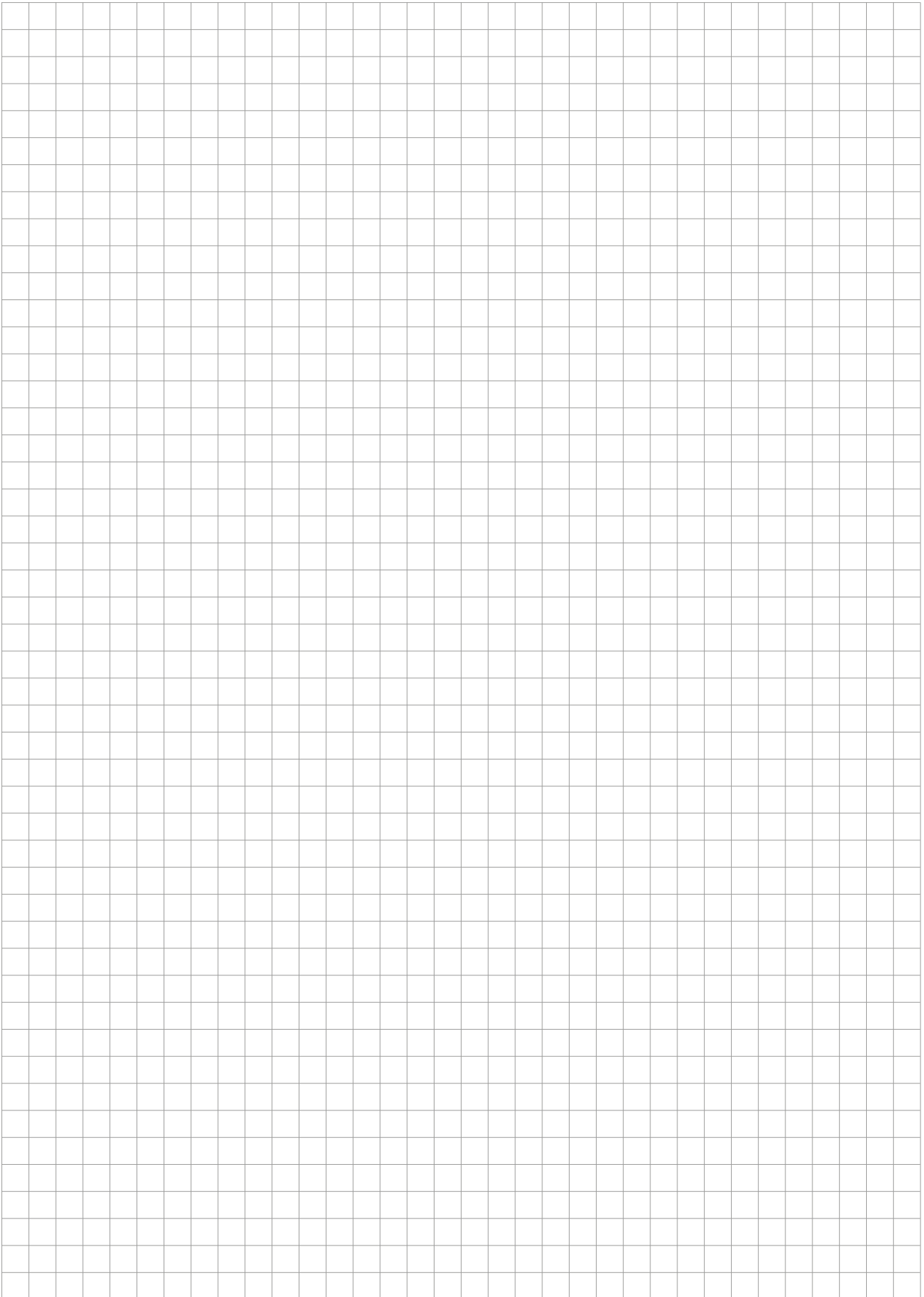

F

Scheibenfräser
Disc Milling Cutter
M310

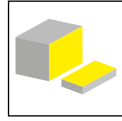

Seite/Page
264

Einschraubfräser
Screw-in cutter
M310

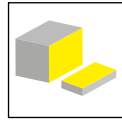

Seite/Page
265-266

Aufsteckfräser
Arbor Mounted Cutter
M310

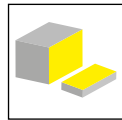

Seite/Page
267-270

Wendeschneidplatte
Indexable insert
S310

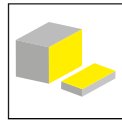

Seite/Page
271-273

F

M310



F

Scheibenfräser
Einschraubfräser
Aufsteckfräser

Trennbreite 3 - 5 mm
Schneidkreis-Ø 50 - 200 mm

Disc Milling Cutter
Screw-in Cutter
Arbor Mounted Cutter

Width of slot 3 - 5 mm
Cutting edge Ø 50 - 200 mm



Abbildung = rechtsschneidend
Picture = right hand cutting version

F

Bestellnummer Part number	Z	Ds	t _{max}	d ₂	b ₂	d ₃	w	rechte WSP right hand insert	linke WSP left hand insert	HWS
M310.0080.27.03	8	80	18	27	8	40	3	4x RS310.3017...	4x LS310.3017...	310017R • 310017L
M310.0080.27.04	8	80	18	27	8	40	4	4x RS310.4023...	4x LS310.4023...	310023R • 310023L
M310.0080.27.05	8	80	18	27	8	40	5	4x RS310.5028...	4x LS310.5028...	310028R • 310028L
M310.0100.32.03	10	100	25	32	8	46	3	5x RS310.3017...	5x LS310.3017...	310017R • 310017L
M310.0100.32.04	10	100	25	32	8	46	4	5x RS310.4023...	5x LS310.4023...	310023R • 310023L
M310.0100.32.05	10	100	25	32	8	46	5	5x RS310.5028...	5x LS310.5028...	310028R • 310028L
M310.0125.40.03	12	125	32	40	10	54	3	6x RS310.3017...	6x LS310.3017...	310017R • 310017L
M310.0125.40.04	12	125	32	40	10	54	4	6x RS310.4023...	6x LS310.4023...	310023R • 310023L
M310.0125.40.05	12	125	32	40	10	54	5	6x RS310.5028...	6x LS310.5028...	310028R • 310028L
M310.0160.40.03	16	160	50	40	10	54	3	8x RS310.3017...	8x LS310.3017...	310017R • 310017L
M310.0160.40.04	16	160	50	40	10	54	4	8x RS310.4023...	8x LS310.4023...	310023R • 310023L
M310.0160.40.05	16	160	50	40	10	54	5	8x RS310.5028...	8x LS310.5028...	310028R • 310028L
M310.0200.40.04	20	200	70	40	10	54	4	10x RS310.4023...	10x LS310.4023...	310023R • 310023L
M310.0200.40.05	20	200	70	40	10	54	5	10x RS310.5028...	10x LS310.5028...	310028R • 310028L

Bohrung (d2) mit Längsnut nach DIN 138
Bore (d2) with longitudinal keyway to DIN 138

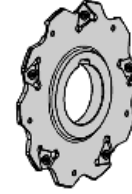
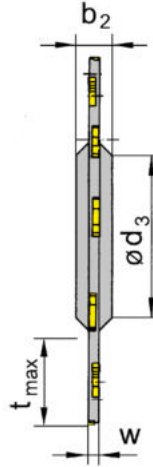
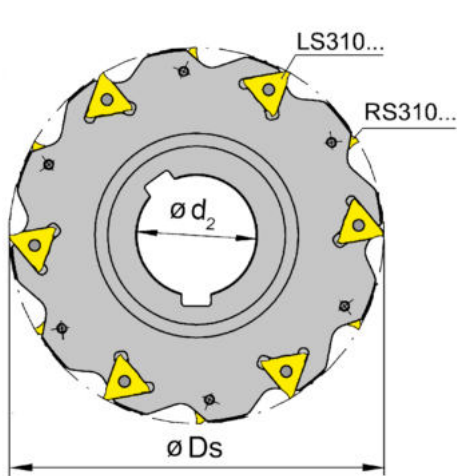
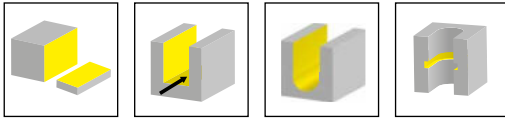
Ersatzteile

Spare Parts

Scheibenfräser Disc Milling Cutter	Spannschraube Clamping Screw	TORX PLUS®-Schlüssel TORX PLUS® Wrench
M310...03	030.0324.T7P	T7PL
M310...04	030.3535.T8P	T8PL
M310...05	030.3543.T8P	T8PL



Abbildung = rechtsschneidend
Picture = right hand cutting version

Bestellnummer Part number	Z	Ds	h	l_2	d_2	d_4	SW	w	t_{max}	rechte WSP right hand insert	linke WSP left hand insert	HWS	HMS
M310.0050.M10.03	6	50	33	13	M10	18	15	3	15	3x RS310.3017...	3x LS310.3017...	310017R • 310017L	10001
M310.0050.M10.04	6	50	34	14	M10	18	15	4	15	3x RS310.4023...	3x LS310.4023...	310023R • 310023L	10001
M310.0050.M10.05	6	50	35	15	M10	18	15	5	15	3x RS310.5028...	3x LS310.5028...	310028R • 310028L	10001
M310.0063.M12.03	6	63	39	15	M12	21	17	3	20	3x RS310.3017...	3x LS310.3017...	310017R • 310017L	12001
M310.0063.M12.04	6	63	40	16	M12	21	17	4	20	3x RS310.4023...	3x LS310.4023...	310023R • 310023L	12001
M310.0063.M12.05	6	63	41	17	M12	21	17	5	20	3x RS310.5028...	3x LS310.5028...	310028R • 310028L	12001

Ersatzteile
Spare Parts

Einschraubfräser Screw-in cutter	Spannschraube Clamping Screw	TORX PLUS®-Schlüssel TORX PLUS® Wrench
M310...03	030.0324.T7P	T7PL
M310...04	030.3535.T8P	T8PL
M310...05	030.3543.T8P	T8PL

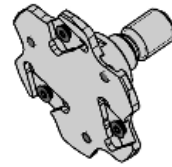
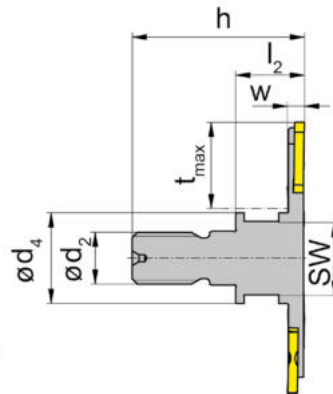
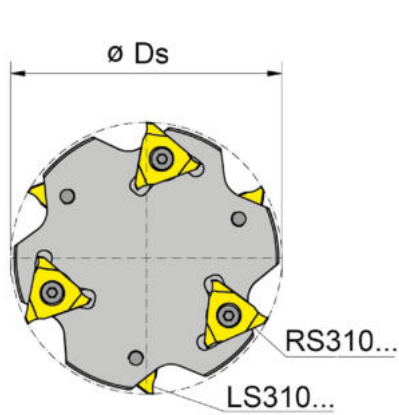
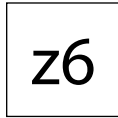
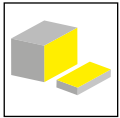



Abbildung = rechtsschneidend
Picture = right hand cutting version

F

Bestellnummer Part number	Z	Ds	h	l ₂	d ₂	d ₄	SW	w	t _{max}	rechte WSP right hand insert	linke WSP left hand insert	HWS	HMS
M310.0050.M10.03.IK	6	50	33	13	M10	18	15	3	15	3xRS310.3017..	3xLS310.3017..	310017R • 310017L	10001
M310.0050.M10.04.IK	6	50	34	14	M10	18	15	4	15	3xRS310.4023..	3xLS310.4023..	310023R • 310023L	10001
M310.0050.M10.05.IK	6	50	35	15	M10	18	15	5	15	3xRS310.5028..	3xLS310.5028..	310028R • 310028L	10001
M310.0063.M12.03.IK	6	63	39	15	M12	21	17	3	20	3xRS310.3017..	3xLS310.3017..	310017R • 310017L	12001
M310.0063.M12.04.IK	6	63	40	16	M12	21	17	4	20	3xRS310.4023..	3xLS310.4023..	310023R • 310023L	12001
M310.0063.M12.05.IK	6	63	41	17	M12	21	17	5	20	3xRS310.5028..	3xLS310.5028..	310028R • 310028L	12001

Ersatzteile
Spare Parts

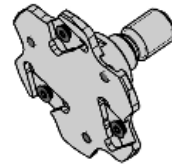
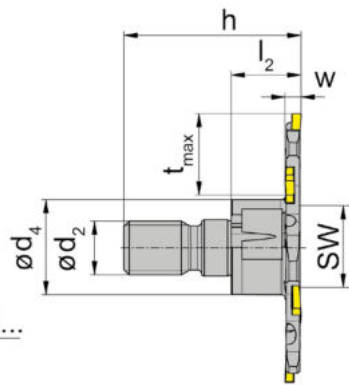
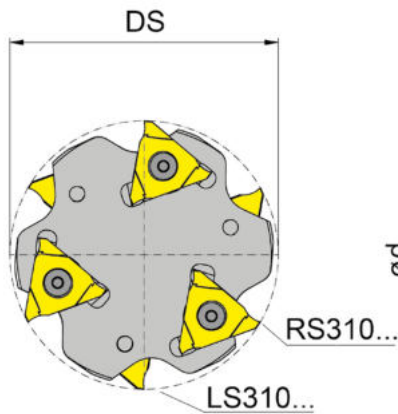
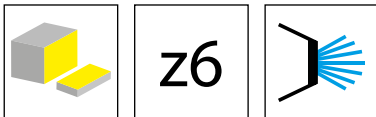
Einschraubfräser Screw-in cutter	Spannschraube Clamping Screw	TORX PLUS®-Schlüssel TORX PLUS® Wrench
M310...03	030.0324.T7P	T7PL
M310...04	030.3535.T8P	T8PL
M310...05	030.3543.T8P	T8PL



Abbildung = rechtsschneidend
Picture = right hand cutting version

Bestellnummer Part number	Z	Ds	t _{max}	h	d ₂	d ₃	w	rechte WSP right hand insert	linke WSP left hand insert	HWS
M310.0080.22.03	8	80	23	40	33	22	3	4x RS310.3017...	4x LS310.3017...	310017R • 310017L
M310.1100.27.03	10	100	25	50	48	27	3	5x RS310.3017...	5x LS310.3017...	310017R • 310017L
M310.1125.27.03	12	125	35,7	50	48	27	3	6x RS310.3017...	6x LS310.3017...	310017R • 310017L
M310.1125.32.03	12	125	32,5	50	58	32	3	6x RS310.3017...	6x LS310.3017...	310017R • 310017L
M310.1125.40.03	12	125	26,5	50	70	40	3	6x RS310.3017...	6x LS310.3017...	310017R • 310017L
M310.1160.40.03	16	160	44	50	70	40	3	6x RS310.3017...	6x LS310.3017...	310017R • 310017L

Bohrung (d3) mit Quernut nach DIN 138
Bore (d3) with cross keyway to DIN 138

Ersatzteile
Spare Parts

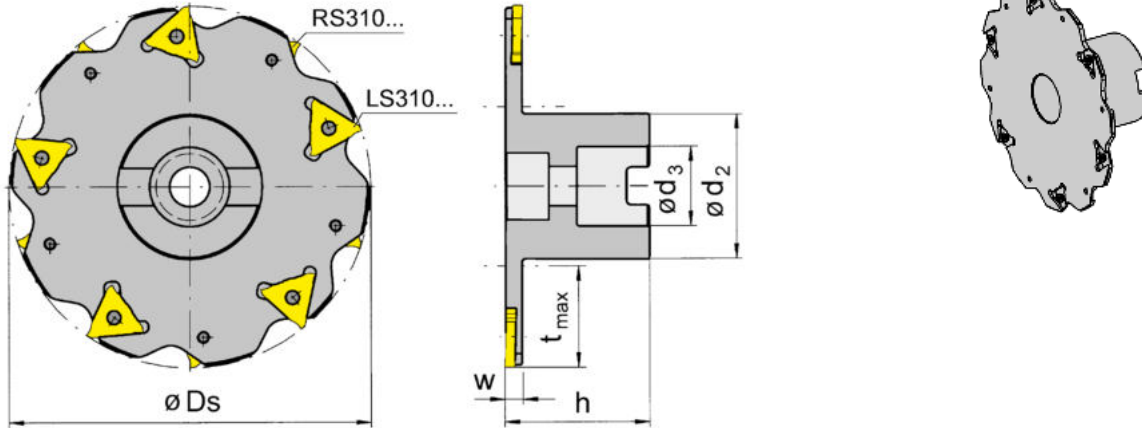
Aufsteckfräser Arbor Mounted Cutter	Spannschraube Clamping Screw	TORX PLUS®-Schlüssel TORX PLUS® Wrench
M310...	030.0324.T7P	T7PL





Abbildung = rechtsschneidend
Picture = right hand cutting version

F

Bestellnummer Part number	Z	Ds	t _{max}	h	d ₂	d ₃	w	rechte WSP right hand insert	linke WSP left hand insert	HWS
M310.0080.22.04	8	80	23	40	33	22	4	4x RS310.4023...	4x LS310.4023...	310023R • 310023L
M310.0080.22.05	8	80	23	40	33	22	5	4x RS310.5028...	4x LS310.5028...	310028R • 310028L
M310.1100.27.04	10	100	25	50	48	27	4	5x RS310.4023...	5x LS310.4023...	310023R • 310023L
M310.1100.27.05	10	100	25	50	48	27	5	5x RS310.5028...	5x LS310.5028...	310028R • 310028L
M310.1125.27.04	12	125	37,5	50	48	27	4	6x RS310.4023...	6x LS310.4023...	310023R • 310023L
M310.1125.32.04	12	125	32	50	56	32	4	6x RS310.4023...	6x LS310.4023...	310023R • 310023L
M310.1125.40.04	12	125	26,5	50	70	40	4	6x RS310.4023...	6x LS310.4023...	310023R • 310023L
M310.1125.27.05	12	125	37,5	50	48	27	5	6x RS310.5028...	6x LS310.5028...	310028R • 310028L
M310.1125.32.05	12	125	32,5	50	56	32	5	6x RS310.5028...	6x LS310.5028...	310028R • 310028L
M310.1125.40.05	12	125	26,5	50	70	40	5	6x RS310.5028...	6x LS310.5028...	310028R • 310028L
M310.1160.40.04	16	160	44	50	70	40	4	8x RS310.4023...	8x LS310.4023...	310023R • 310023L
M310.1160.40.05	16	160	44	50	70	40	5	8x RS310.5028...	8x LS310.5028...	310028R • 310028L
M310.1200.40.04	20	200	64	50	70	40	4	10x RS310.4023...	10x LS310.4023...	310023R • 310023L
M310.1200.40.05	20	200	64	50	70	40	5	10x RS310.5028...	10x LS310.5028...	310028R • 310028L

Bohrung (d3) mit Quernut nach DIN 138
Bore (d3) with cross keyway to DIN 138

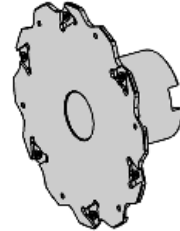
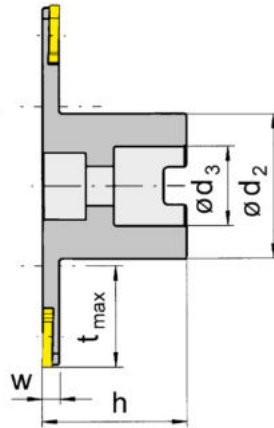
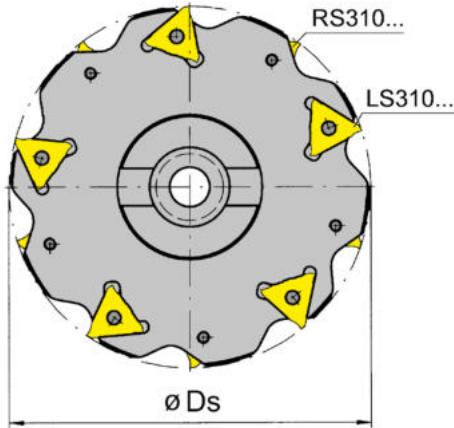
Ersatzteile

Spare Parts

Aufsteckfräser Arbor Mounted Cutter	Spannschraube Clamping Screw	TORX PLUS®-Schlüssel TORX PLUS® Wrench
M310...04	030.3535.T8P	T8PL
M310...05	030.3543.T8P	T8PL



Abbildung = rechtsschneidend
Picture = right hand cutting version

Bestellnummer Part number	Z	Ds	t _{max}	h	d ₂	d ₃	w	rechte WSP right hand insert	linke WSP left hand insert	HWS
M310.0063.16.03.IK	6	63	17,5	35	26	16	3	3x RS310.3017...	3x LS310.3017...	310017R • 310017L
M310.0063.16.04.IK	6	63	17,5	35	26	16	4	3x RS310.4023...	3x LS310.4023...	310023R • 310023L
M310.0063.16.05.IK	6	63	17,5	35	26	16	5	3x RS310.5028...	3x LS310.5028...	310028R • 310028L
M310.0080.16.03.IK	8	80	25	40	28	16	3	4x RS310.3017...	4x LS310.3017...	310017R • 310017L
M310.0080.16.04.IK	8	80	25	40	28	16	4	4x RS310.4023...	4x LS310.4023...	310023R • 310023L
M310.0080.16.05.IK	8	80	25	40	28	16	5	4x RS310.5028...	4x LS310.5028...	310028R • 310028L
M310.0080.22.03.IK	8	80	23	40	33	22	3	4x RS310.3017...	4x LS310.3017...	310017R • 310017L
M310.0080.22.04.IK	8	80	23	40	33	22	4	4x RS310.4023...	4x LS310.4023...	310023R • 310023L
M310.0080.22.05.IK	8	80	23	40	33	22	5	4x LS310.5028...	4x RS310.5028...	310028R • 310028L
M310.1100.27.03.IK	10	100	25	50	48	27	3	5x RS310.3017...	5x LS310.3017...	310017R • 310017L
M310.1100.27.04.IK	10	100	25	50	48	27	4	5x RS310.4023...	5x LS310.4023...	310023R • 310023L

Bohrung (d3) mit Quernut nach DIN 138
Bore (d3) with cross keyway to DIN 138

Ersatzteile

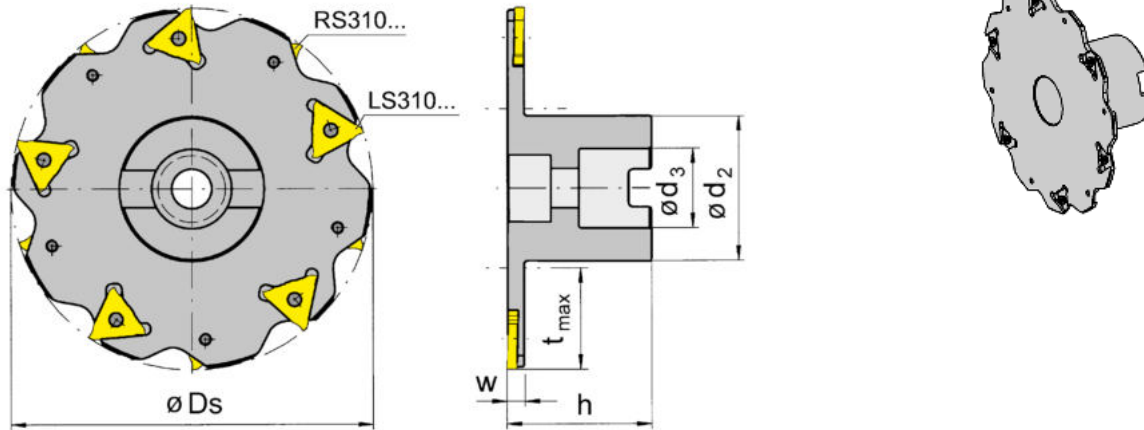
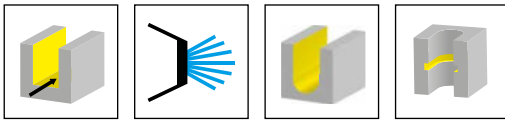
Spare Parts

Aufsteckfräser Arbor Mounted Cutter	Spannschraube Clamping Screw	TORX PLUS®-Schlüssel TORX PLUS® Wrench
M310...03	030.0324.T7P	T7PL
M310...04	030.3535.T8P	T8PL
M310...05	030.3543.T8P	T8PL





Abbildung = rechtsschneidend
Picture = right hand cutting version

F

Bestellnummer Part number	Z	Ds	t _{max}	h	d ₂	d ₃	w	rechte WSP right hand insert	linke WSP left hand insert	HWS
M310.1125.27.03.IK	12	125	37,5	50	48	27	3	6x RS310.3017...	6x LS310.3017...	310017R • 310017L
M310.1125.27.04.IK	12	125	37,5	50	48	27	4	6x RS310.4023...	6x LS310.4023...	310023R • 310023L
M310.1125.27.05.IK	12	125	37,5	50	48	27	5	6x RS310.5028...	6x LS310.5028...	310028R • 310028L
M310.1125.32.03.IK	12	125	32	50	56	32	3	6x LS310.3017...	6x LS310.3017...	310017R • 310017L
M310.1125.32.04.IK	12	125	32	50	56	32	4	6x LS310.4023...	6x RS310.4023...	310023R • 310023L
M310.1125.32.05.IK	12	125	32	50	56	32	5	6x LS310.5028...	6x RS310.5028...	310028R • 310028L
M310.1125.40.05.IK	12	125	26,5	50	70	40	5	6x RS310.5028...	6x LS310.5028...	310028R • 310028L
M310.1160.40.03.IK	16	160	44	50	70	40	3	8x RS310.3017...	8x LS310.3017...	310017R • 310017L
M310.1160.40.04.IK	16	160	44	50	70	40	4	8x RS310.4023...	8x LS310.4023...	310023R • 310023L
M310.1160.40.05.IK	16	160	44	50	70	40	5	8x LS310.5028...	3x RS310.5028...	310028R • 310028L
M310.1200.40.04.IK	20	200	64	50	70	40	4	10x LS310.4023...	10x RS310.4023...	310023R • 310023L
M310.1200.40.05.IK	20	200	64	50	70	40	5	10x LS310.5028...	10x RS310.5028...	310028R • 310028L

Bohrung (d3) mit Quernut nach DIN 138
Bore (d3) with cross keyway to DIN 138

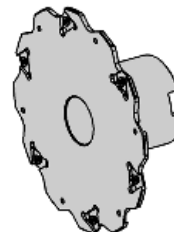
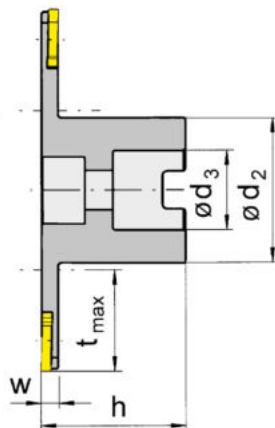
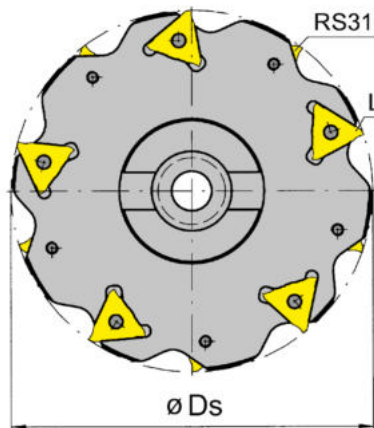
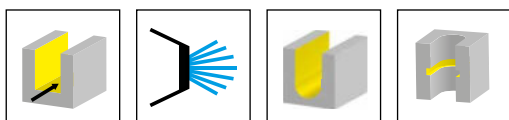
Ersatzteile

Spare Parts

Aufsteckfräser Arbor Mounted Cutter	Spannschraube Clamping Screw	TORX PLUS®-Schlüssel TORX PLUS® Wrench
M310...03	030.0324.T7P	T7PL
M310...04	030.3535.T8P	T8PL
M310...05	030.3543.T8P	T8PL

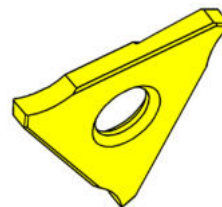
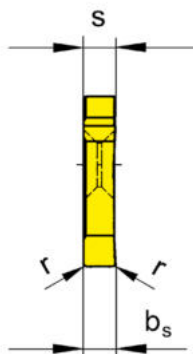
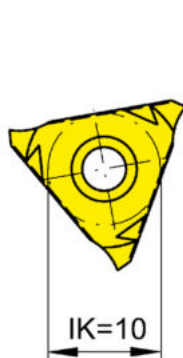
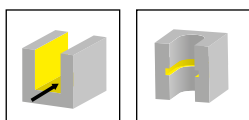

R = rechts wie gezeichnet
R = right hand version shown

L = links spiegelbildlich
L = left hand version

▲ ab Lager
on stock

HM-Sorten
Carbide grades
Δ 4 Wochen
4 weeks

Bestellnummer Part number	w	r	b _s	s	HIS	AS45	DD25	IG35	TF45	TN35
RS310.3017.00	3	0,15	1,7	1,6	310017R	▲	▲	▲		
RS310.3118.00	3,175	0,15	1,8	1,6	310018R	▲				
RS310.4023.00	4	0,2	2,3	2,2	310023R	▲	▲	▲	▲	▲
RS310.5028.00	5	0,2	2,8	2,7	310028R	▲	▲	▲	▲	▲
LS310.3017.00	3	0,15	1,7	1,6	310017L	▲	▲	▲		
LS310.3118.00	3,175	0,15	1,8	1,6	310018L	▲				
LS310.4023.00	4	0,2	2,3	2,2	310023L	▲	▲	▲	▲	▲
LS310.5028.00	5	0,2	2,8	2,7	310028L	▲	▲	▲	▲	▲
P	●	-	-	●	●					
M	●	-	●	●	●					
K	●	-	●	●	●					
N	○	●	-	●	●					
S	●	○	●	●	●					
H	-	-	-	-	-					



Wendeschneidplatte

Indexable insert

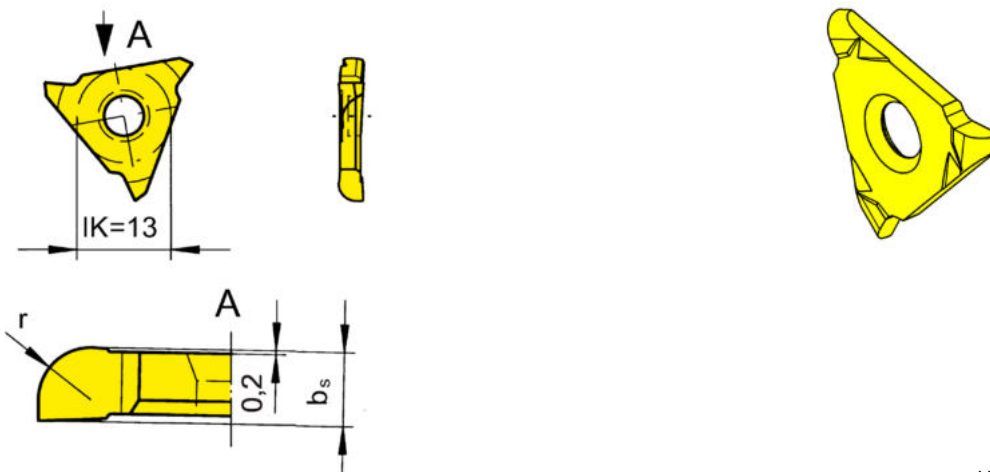
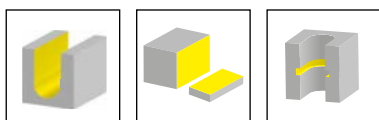

HM-Sorten
Carbide grades
▲ ab Lager
on stock
Δ 4 Wochen
4 weeks

R = rechts wie gezeichnet
R = right hand version shown

L = links spiegelbildlich
L = left hand version

▲ ab Lager
on stock

Δ 4 Wochen
4 weeks

F

Bestellnummer Part number	w	r	b _s	s	HIS	AS45
RS310.3017.04	3	0,4	1,7	1,57	310017R	Δ
RS310.3017.05	3	0,5	1,7	1,57	310017R	Δ
RS310.3017.10	3	1	1,7	1,57	310017R	▲
RS310.3017.15	3	1,5	1,7	1,57	310017R	Δ
RS310.4023.04	4	0,4	2,3	2,17	310023R	Δ
RS310.4023.05	4	0,5	2,3	2,17	310023R	Δ
RS310.4023.10	4	1	2,3	2,17	310023R	▲
RS310.4023.15	4	1,5	2,3	2,17	310023R	Δ
RS310.4023.16	4	1,6	2,3	2,17	310023R	Δ
RS310.4023.20	4	2	2,3	2,17	310023R	▲
LS310.3017.04	3	0,4	1,7	1,57	310017L	Δ
LS310.3017.05	3	0,5	1,7	1,57	310017L	Δ
LS310.3017.10	3	1	1,7	1,57	310017L	▲
LS310.3017.15	3	1,5	1,7	1,57	310017L	Δ
LS310.4023.04	4	0,4	2,3	2,17	310023L	Δ
LS310.4023.05	4	0,5	2,3	2,17	310023L	Δ
LS310.4023.10	4	1	2,3	2,17	310023L	▲
LS310.4023.15	4	1,5	2,3	2,17	310023L	Δ
LS310.4023.16	4	1,6	2,3	2,17	310023L	Δ
LS310.4023.20	4	2	2,3	2,17	310023L	▲

P	●
M	●
K	●
N	○
S	●
H	-

Wendeschnidplatte

Indexable insert

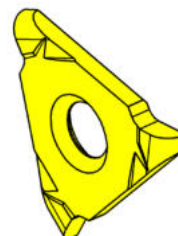
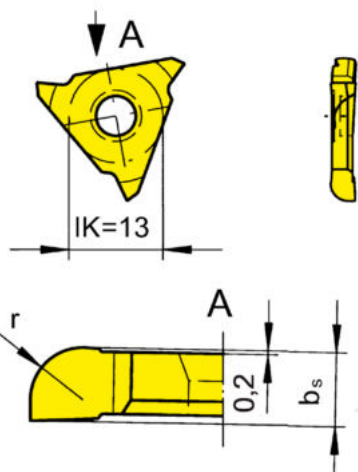
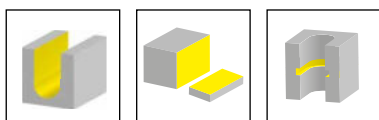

R = rechts wie gezeichnet
R = right hand version shown

L = links spiegelbildlich
L = left hand version

▲ ab Lager
on stock

HM-Sorten
Carbide grades
Δ 4 Wochen
4 weeks

Bestellnummer Part number	w	r	b _s	s	HIS	AS45
RS310.5028.04	5	0,4	2,68	2,62	310028R	Δ
RS310.5028.05	5	0,5	2,68	2,62	310028R	▲
RS310.5028.10	5	1	2,68	2,62	310028R	▲
RS310.5028.15	5	1,5	2,68	2,62	310028R	▲
RS310.5028.16	5	1,6	2,68	2,62	310028R	Δ
RS310.5028.20	5	2	2,68	2,62	310028R	▲
LS310.5028.04	5	0,4	2,68	2,62	310028L	Δ
LS310.5028.05	5	0,5	2,68	2,62	310028L	▲
LS310.5028.10	5	1	2,68	2,62	310028L	▲
LS310.5028.15	5	1,5	2,68	2,62	310028L	▲
LS310.5028.16	5	1,6	2,68	2,62	310028L	Δ
LS310.5028.20	5	2	2,68	2,62	310028L	▲
						P ●
						M ●
						K ●
						N o
						S ●
						H -



F

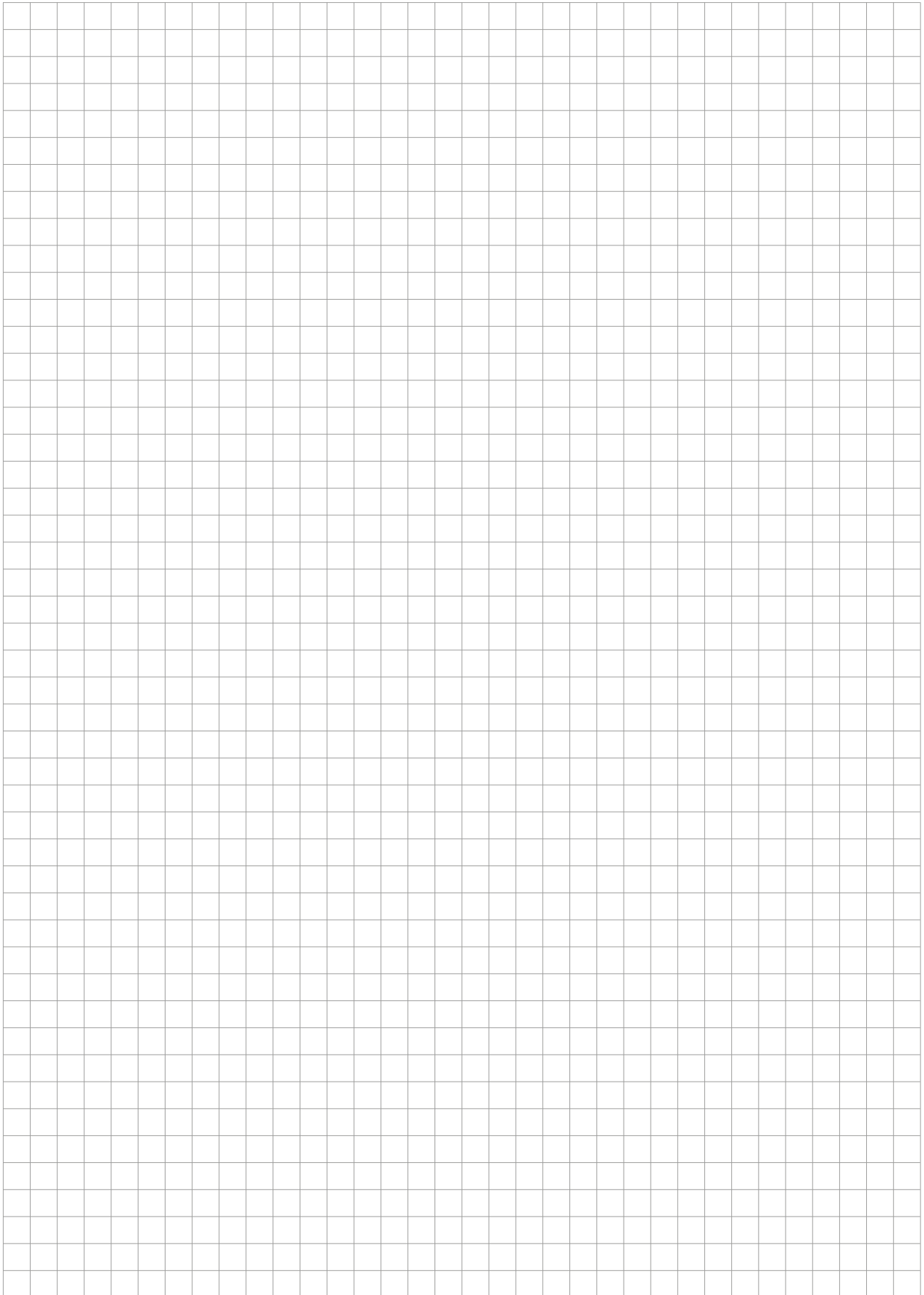



G

System/System	Seite/Page
M304	276
M306	284
M308	296
M311	306
M313	316
M328	326
M332	336
M275	342
380	348

Übersicht
Overview

Seite/Page
278

Klemmhalter
Toolholder
M304

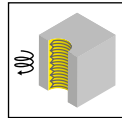

Seite/Page
279

Schneidplatte
Insert
304

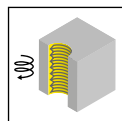

Seite/Page
280-282

G

Achtung:

Beim Nenndurchmesser handelt es sich immer um den größten \emptyset am Gewinde. In der Regel richtet sich die Bezeichnung nach der Größe des Gewindes.

Bsp: M12 x 1 -> Nenndurchmesser 12

Bei Unterschreitung des angegebenen Nenndurchmessers wird durch den Nachschnitt des Werkzeugs kein lehrenhaltiges Gewinde mehr erreicht.

Attention:

The nominal diameter is always the largest \emptyset on the thread. As a rule, the designation is based on the size of the thread.

Example: M12 x 1 -> nominal diameter 12

Recutting of the milling tool will create profile errors if the nominal diameter of the component will be smaller than recommended.

M304



G

**Gewindefräser
(zirkular)**

ab Schneidkreis \varnothing 7,7 mm

**Thread Milling Cutter
(by circular interpolation)**

from Cutting edge \varnothing 7,7 mm

Teilprofil, metrisch Typ 304

Partial profile, metric type 304

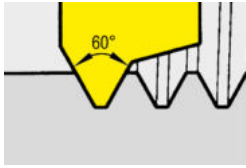

Steigung/ Pitch P	0,5	0,75	1,0	1,25	1,5
Nenndurchmesser / Nominal diameter					
Typ / type 304 / Ds 7,7					
304.0515.01	≥ 9	≥ 9	≥ 9	≥ 10	≥ 10

Vollprofil, metrisch Typ 304

Full profile, metric type 304

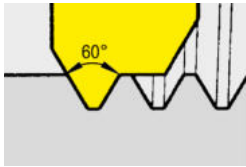

Steigung/ Pitch P	1,5
Nenndurchmesser Nominal diameter	
Typ / type 304 / Ds 7,7	
304.0815.02	≥ 12

Vollprofil, Whitworth Typ 304

Full profile, Whitworth type 304

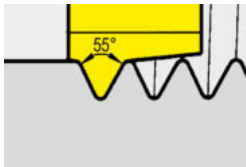

Gg/'' / tpi	19	14	11
Gewinde / Thread			
Typ / type 304 / Ds 7,7			
304.05519.02	G 1/4''		



Abbildung = rechtsschneidend
Picture = right hand cutting version

Bestellnummer Part number	d	l ₁	l ₂	d ₁	Form	HWS
M304.0508.02A	8	63	20	5,4	A	304044R
M304.0508.03A	8	70	27	5,4	A	304044R
M304.0508.02B	8	63	20	5,4	B	304044R
M304.0508.03B	8	70	27	5,4	B	304044R

Ds siehe Schneidplatten
Ds see inserts

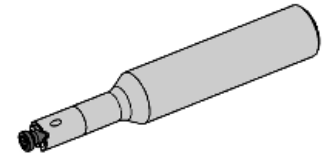
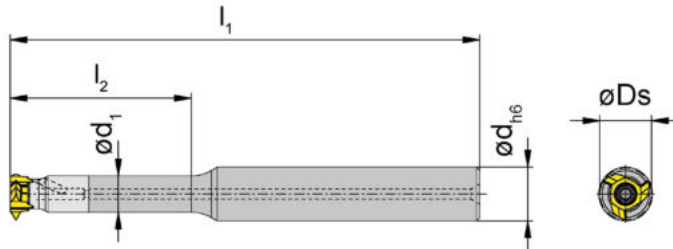
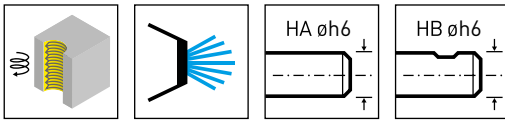

Ersatzteile
Spare Parts

Klemmhalter Toolholder	Spannschraube Clamping Screw	TORX PLUS®-Schlüssel TORX PLUS® Wrench
M304...	1.8.4T6EP	T6PL



Abbildung = rechtsschneidend
Picture = right hand cutting version

HM-Sorten
Carbide grades
▲ ab Lager
on stock
△ 4 Wochen
4 weeks

Bestellnummer Part number	P	P _{max}	E	s	D _s	Z	HIS	AS45
304.0515.01	0,5	1,5	1,9	2,75	7,7	3	304044R	▲
	P ●							
	M ●							
	K ●							
	N ○							
	S ●							
	H -							

G

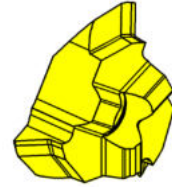
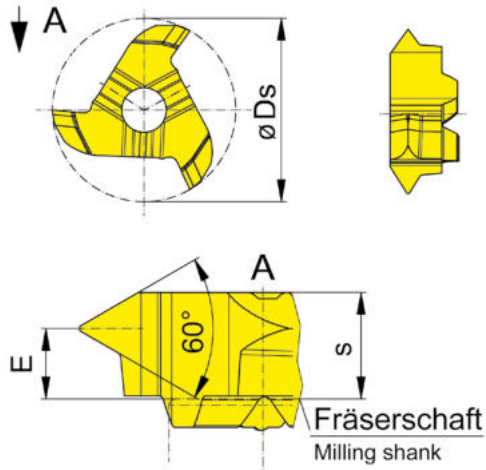
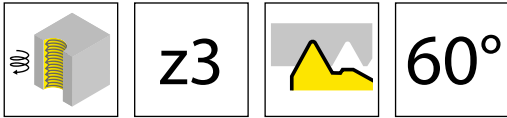

Abbildung = rechtsschneidend
Picture = right hand cutting version

▲ ab Lager
on stock

HM-Sorten
Carbide grades
Δ 4 Wochen
4 weeks

Bestellnummer Part number	P	E	s	Ds	HIS	AS45
304.0815.02	1,5	2	2,75	7,7	304044R	▲
	P ●					
	M ●					
	K ●					
	N ○					
	S ●					
	H -					

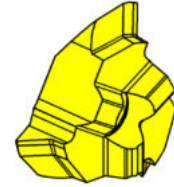
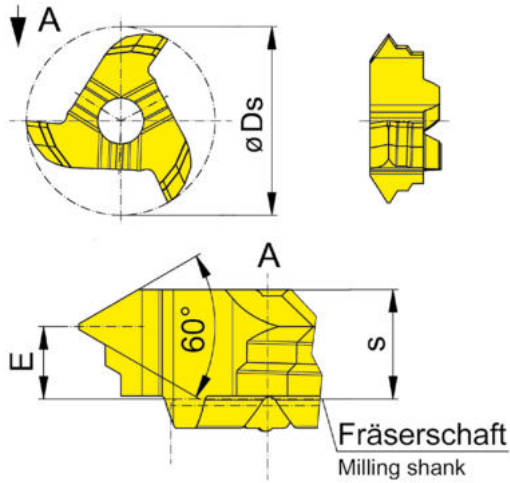
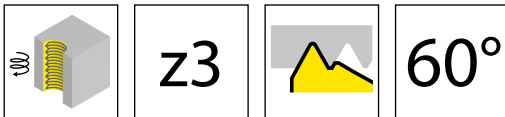



Abbildung = rechtsschneidend
Picture = right hand cutting version

▲ ab Lager
on stock

HM-Sorten
Carbide grades
Δ 4 Wochen
4 weeks

Bestellnummer Part number	TPI	E	s	Ds	HIS	AS45
304.5519.02	19	1,5	2,75	7,7	304044R	▲
						P ●
						M ●
						K ●
						N ○
						S ●
						H -

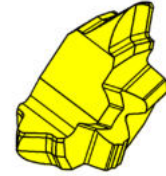
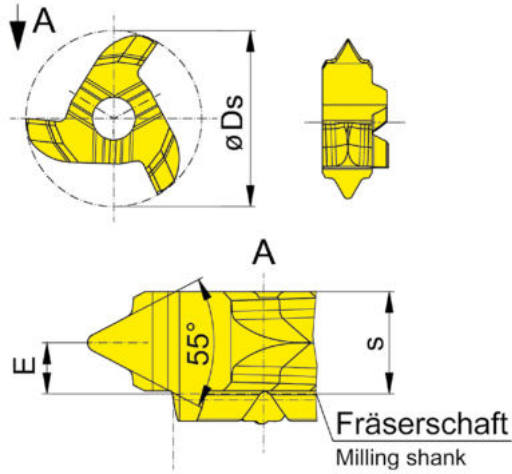
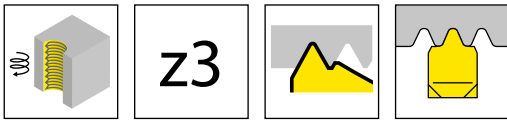
G

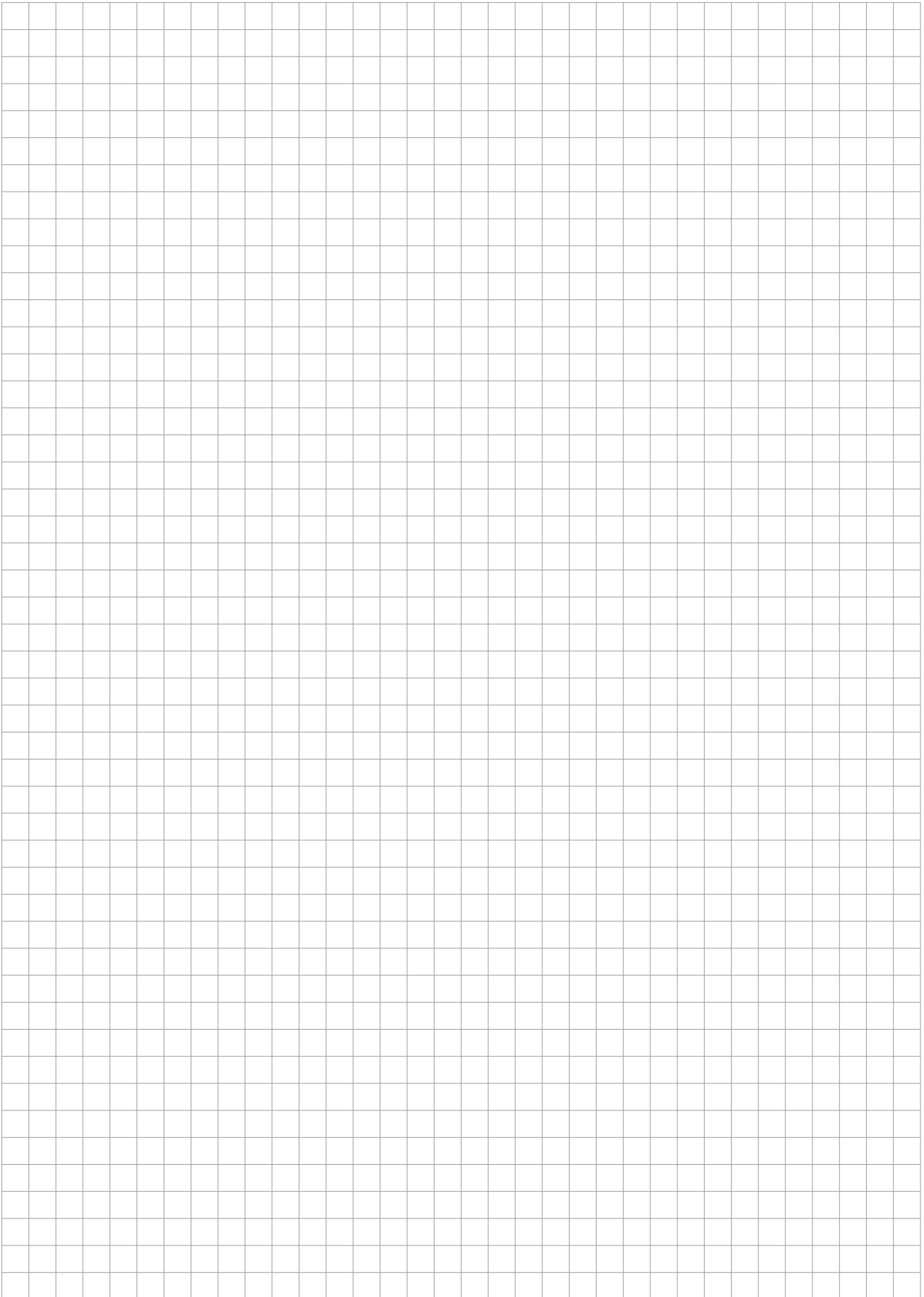

Übersicht
Overview

Seite/Page
286

M306

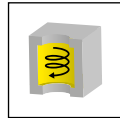

Seite/Page
287

Schneidplatte
Insert
108/306/606

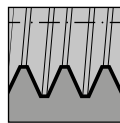

Seite/Page
288

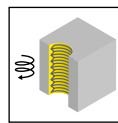

Seite/Page
289-294

G

Achtung:

Beim Nenndurchmesser handelt es sich immer um den größten \emptyset am Gewinde. In der Regel richtet sich die Bezeichnung nach der Größe des Gewindes.

Bsp: M12 x 1 -> Nenndurchmesser 12

Bei Unterschreitung des angegebenen Nenndurchmessers wird durch den Nachschnitt des Werkzeugs kein lehrenhaltiges Gewinde mehr erreicht.

Attention:

The nominal diameter is always the largest \emptyset on the thread. As a rule, the designation is based on the size of the thread.

Example: M12 x 1 -> nominal diameter 12

Recutting of the milling tool will create profile errors if the nominal diameter of the component will be smaller than recommended.

M306



G

**Gewindefräser
(zirkular)**

ab Schneidkreis \varnothing 9,6 mm

**Thread Milling Cutter
(by circular interpolation)**

from Cutting edge \varnothing 9,6 mm

Teilprofil, metrisch Typ 108, 306, 606

Partial profile, metric type 108, 306, 606

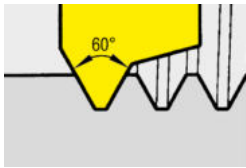

Steigung/ Pitch P	0,5	0,75	1,0	1,25	1,5	1,75	2,0	2,5	3,0
Nenndurchmesser / Nominal diameter									
Typ / type 108 / Ds 9,6									
R/L 108.0205.01	≥ 12	≥ 12							
R/L 108.0510.01			≥ 14	≥ 14					
R/L 108.0815.01					≥ 16	≥ 16			
Typ / type 306 / Ds 10,0									
306.0515.01	≥ 12	≥ 12	≥ 13	≥ 13	≥ 14				
306.1020.01							≥ 16		
Typ / type 306 / Ds 11,7									
306.0815.01					≥ 18				
306.0720.01			≥ 16	≥ 16	≥ 16	≥ 16	≥ 16		
306.2530.01								≥ 20	≥ 20
Typ / type 606 / Ds 10,0									
606.0515.01	≥ 12	≥ 12	≥ 13	≥ 13	≥ 14				
Typ / type 606 / Ds 11,7									
606.0720.01			≥ 16	≥ 16	≥ 16	≥ 16	≥ 16		

Vollprofil, metrisch Typ 306, 606

Full profile, metric type 306



Steigung/ Pitch P	1,5	2,0
Nenndurchmesser Nominal diameter		
Typ / type 306 / Ds 11,7		
306.0815.02	≥ 22	
Typ / type 306 / Ds 10,0		
306.1020.02		≥ 24

Steigung/ Pitch P	1,5
Nenndurchmesser Nominal diameter	
Typ / type 606 / Ds 11,7	
606.0815.02	≥ 22

Vollprofil, Whitworth Typ 306, 606

Full profile, Whitworth type 306, 606

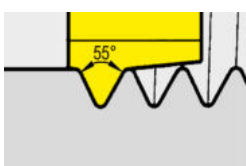

Gg/'' / tpi	19	14	11
Gewinde / Thread			
Typ / type 306 / Ds 9,7			
306.5519.10.02	G ¹ / ₄ ''		
Typ / type 306 / Ds 11,7			
306.5519.02	G ³ / ₈ ''		
306.5514.02		G ¹ / ₂ ''	
306.5511.02			G1''
Typ / type 606 / Ds 9,7			
606.5519.10.02	G ¹ / ₄ ''		
Typ / type 606 / Ds 11,7			
606.5519.02	G ³ / ₈ ''		
606.5514.02		G ¹ / ₂ ''	



Abbildung = rechtsschneidend
Picture = right hand cutting version

Bestellnummer Part number	d	l ₁	l ₂	d ₁	Form	HWS
M306.0712.02A	12	90	30	7,3	A	306060R • 306060L
M306.0716.01A	16	100	25	7,3	A	306060R • 306060L
M306.0716.02A	16	110	35	7,3	A	306060R • 306060L
M306.0712.02B	12	90	30	7,3	B	306060R • 306060L
M306.0716.01B	16	100	25	7,3	B	306060R • 306060L
M306.0716.02B	16	110	35	7,3	B	306060R • 306060L
M306.0712.02E	12	90	30	7,3	E	306060R • 306060L
M306.0716.01E	16	100	25	7,3	E	306060R • 306060L
M306.0716.02E	16	110	35	7,3	E	306060R • 306060L

Ds siehe Schneidplatten
Ds see inserts

Ersatzteile
Spare Parts

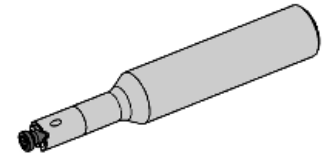
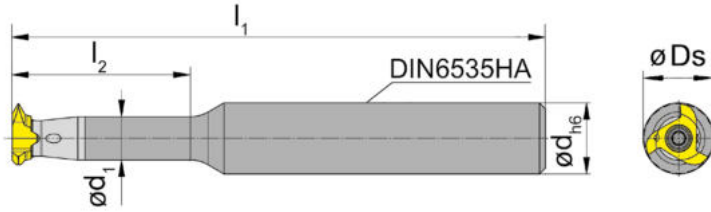
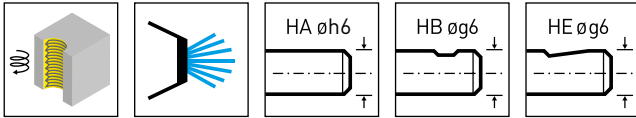
Klemmhalter Toolholder	Spannschraube Clamping Screw	TORX PLUS®-Schlüssel TORX PLUS® Wrench
M306...	2.6.5T8EP	T8PL



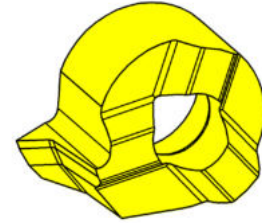
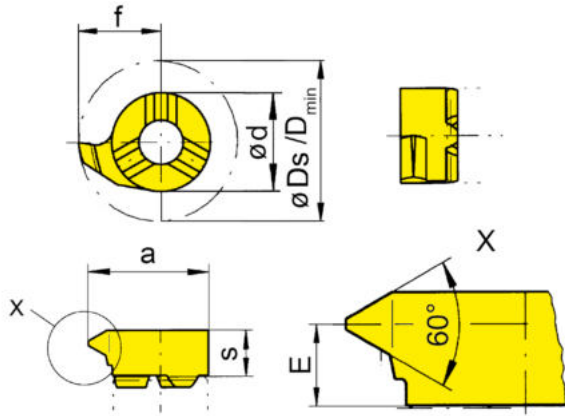

R = rechts wie gezeichnet
R = right hand version shown

L = links spiegelbildlich
L = left hand version

▲ ab Lager
on stock

HM-Sorten
Carbide grades
Δ 4 Wochen
4 weeks

Bestellnummer Part number	P	P _{max}	E	f	a	d	s	D _{min}	D _s	HIS	MG12	EG55	TH35	TI25	TN35
R108.0205.01	0,5	0,75	2,8	4,8	7,8	6	3,6	8	9,6	306060R	▲	▲	▲		▲
R108.0815.01	1,5	1,75	2,6	4,8	7,8	6	3,6	8	9,6	306060R	▲	▲	▲		▲
R108.0510.01	1	1,25	2,8	4,8	7,8	6	3,6	8	9,6	306060R	▲	▲	▲	▲	▲
L108.0205.01	0,5	0,75	2,8	4,8	7,8	6	3,6	8	9,6	306060L	Δ	▲	▲		▲
L108.0815.01	1,5	1,75	2,6	4,8	7,8	6	3,6	8	9,6	306060L	Δ	▲	▲		▲
L108.0510.01	1	1,25	2,8	4,8	7,8	6	3,6	8	9,6	306060L	Δ	▲	▲	▲	▲
P	o	•	•	•	•	•	•	•	•						
M	-	o	•	•	•	•	•	•	•						
K	-	o	•	•	•	•	•	•	•						
N	-	-	•	•	•	•	•	•	•						
S	-	-	•	•	•	•	•	•	•						
H	-	-	-	-	-	-	-	-	-						

G



Abbildung = rechtsschneidend
Picture = right hand cutting version

▲ ab Lager
on stock

HM-Sorten
Carbide grades

△ 4 Wochen
4 weeks

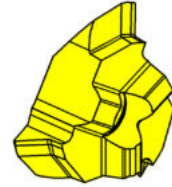
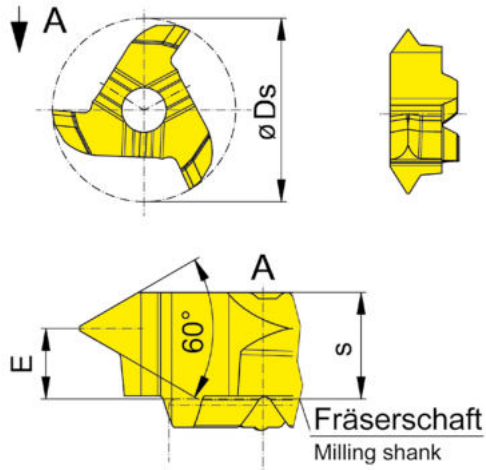
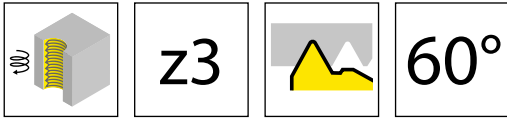
Bestellnummer Part number	P	P _{max}	E	s	D _s	Z	HIS	AS45	TA45	TF45	TI25	TN35
306.0515.01	0,5	1,5	2,3	3,4	10	3	306060R	▲	▲			△
306.1020.01	2	2	2,2	3,4	10	3	306060R	▲			▲	
306.0720.01	1	2	1,95	3,4	11,7	3	306060R	▲		▲	▲	▲
306.0815.01	1,5	1,5	2,25	3,4	11,7	3	306060R	▲		△	▲	▲
306.2530.01	2,5	3	1,7	3,4	11,7	3	306060R	▲		▲	▲	▲
P	●	●	●	●	●	●		●	●	●	●	●
M	●	●	●	●	●	●		●	●	●	●	●
K	●	●	●	●	●	●		●	●	●	●	●
N	○	●	●	●	●	●		●	●	●	●	●
S	●	●	●	●	●	●		●	●	●	●	●
H	-	-	-	-	-	-		-	-	-	-	-





Abbildung = rechtsschneidend
Picture = right hand cutting version

▲ ab Lager
on stock

△ 4 Wochen
4 weeks

HM-Sorten
Carbide grades

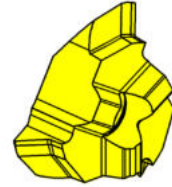
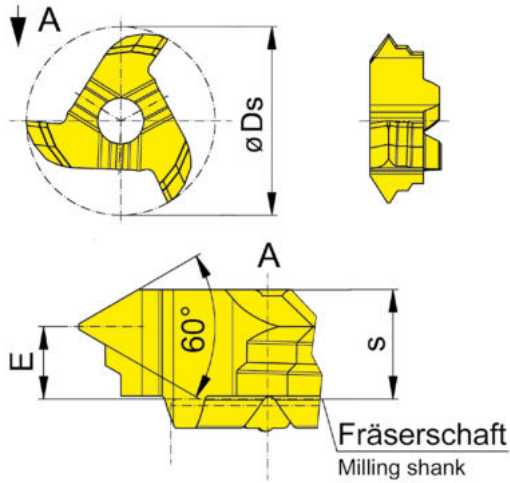
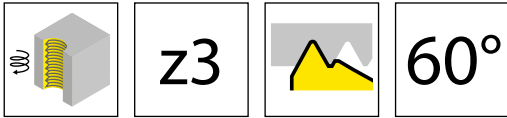
Bestellnummer Part number	P	E	s	Ds	HIS	HM-Sorten Carbide grades	
						AS45	TA45
306.1020.02	2	2,2	3,4	10	306060R	▲	▲
306.0510.02	1	2,5	3,4	11,7	306060R	▲	▲
306.0815.02	1,5	2,25	3,4	11,7	306060R	▲	▲
						P	● ●
						M	● ●
						K	● ●
						N	○ ●
						S	● ●
						H	- -





Abbildung = rechtsschneidend
Picture = right hand cutting version

▲ ab Lager
on stock

HM-Sorten
Carbide grades

Δ 4 Wochen
4 weeks

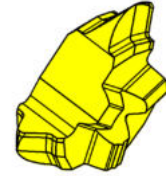
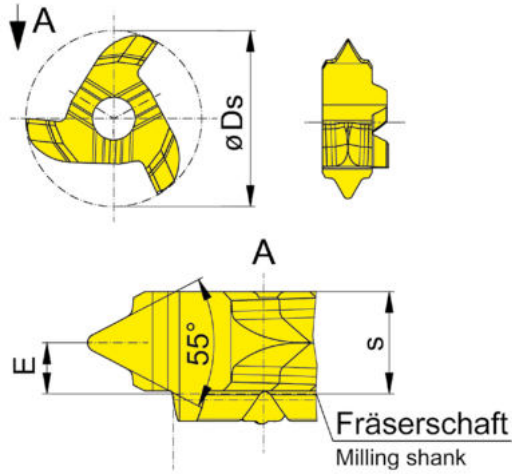
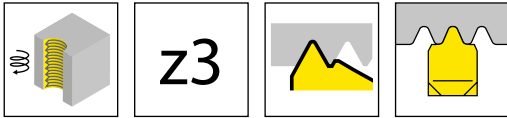
Bestellnummer Part number	TPI	E	s	Ds	HIS	AS45	TA45	TF45	TI25	TN35
306.5519.10.02	19	2,2	3,4	9,7	306060R	▲	▲			
306.5511.02	11	1,7	3,4	11,7	306060R	▲	▲		Δ	
306.5514.02	14	2	3,4	11,7	306060R	▲	▲			Δ
306.5519.02	19	2,2	3,4	11,7	306060R	▲	▲			
P	●	●	●	●	●	●	●	●	●	●
M	●	●	●	●	●	●	●	●	●	●
K	●	●	●	●	●	●	●	●	●	●
N	○	●	●	●	●	●	●	●	●	●
S	●	●	●	●	●	●	●	●	●	●
H	-	-	-	-	-	-	-	-	-	-





Abbildung = rechtsschneidend
Picture = right hand cutting version

▲ ab Lager
on stock

HM-Sorten
Carbide grades
Δ 4 Wochen
4 weeks

Bestellnummer Part number	P	P _{max}	E	s	D _s	Z	HIS	AS45	TA45
606.0515.01	0,5	1,5	2,3	3,15	10	6	306060R	▲	▲
606.0720.01	1	2	1,95	3,15	11,7	6	306060R	▲	▲
	P	●	●						
	M	●	●						
	K	●	●						
	N	○	●						
	S	●	●						
	H	-	-						

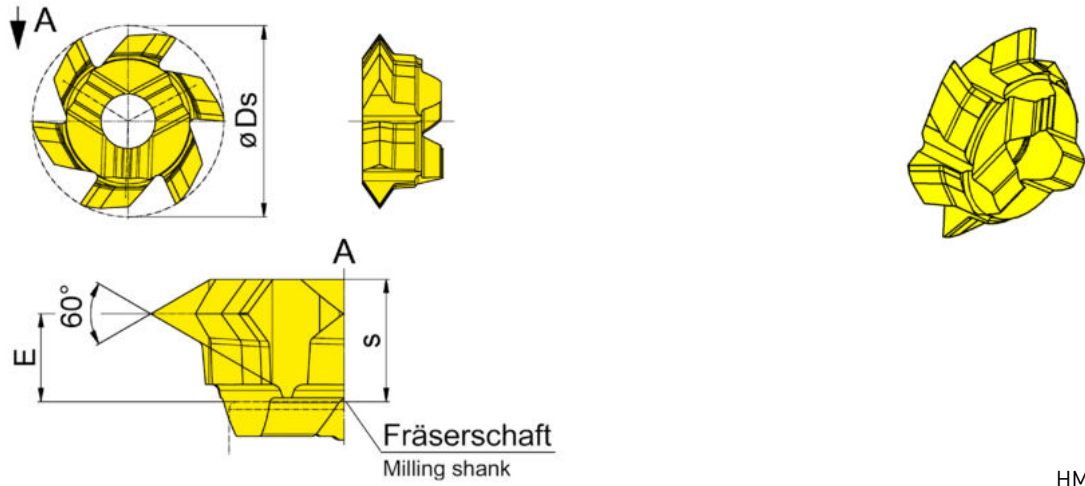
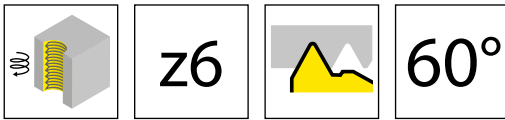
G



Abbildung = rechtsschneidend
Picture = right hand cutting version

▲ ab Lager
on stock

HM-Sorten
Carbide grades
△ 4 Wochen
4 weeks

Bestellnummer Part number	P	E	s	Ds	Z	HIS	AS45	TA45
606.0510.02	1	2,5	3,2	11,7	6	306060R	▲	▲
606.0815.02	1,5	2,25	3,2	11,7	6	306060R	▲	▲
	P	●	●					
	M	●	●					
	K	●	●					
	N	○	●					
	S	●	●					
	H	-	-					

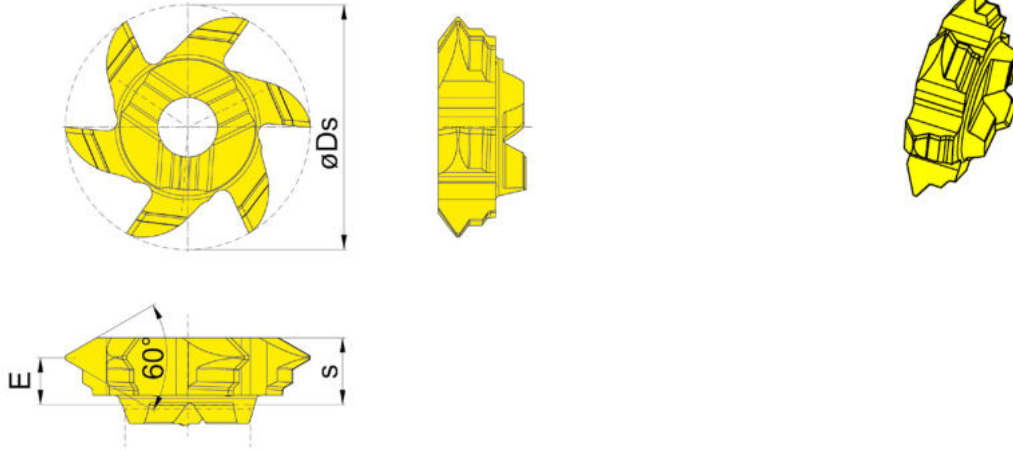
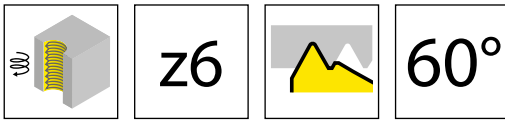



Abbildung = rechtsschneidend
Picture = right hand cutting version

▲ ab Lager
on stock

HM-Sorten
Carbide grades
Δ 4 Wochen
4 weeks

Bestellnummer Part number	TPI	E	s	Ds	HIS	AS45	TA45	TI25
606.5519.10.02	19	2,1	3,3	9,7	306060R	▲	▲	Δ
606.5514.02	14	2	3,3	11,7	306060R	▲	▲	Δ
606.5519.02	19	2,1	3,3	11,7	306060R	▲	▲	Δ
P	●	●	●					
M	●	●	●					
K	●	●	●					
N	○	●	●					
S	●	●	●					
H	-	-	-					

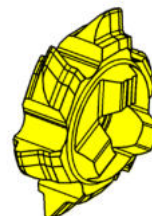
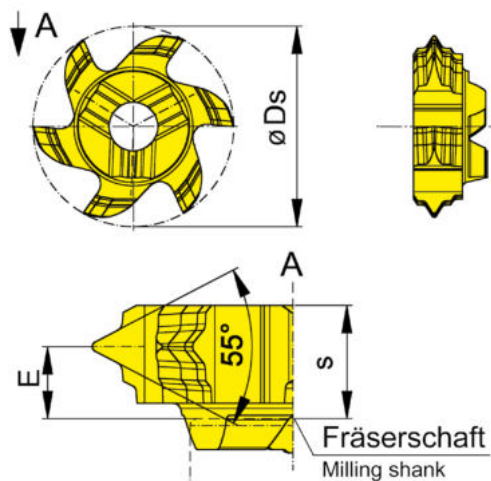
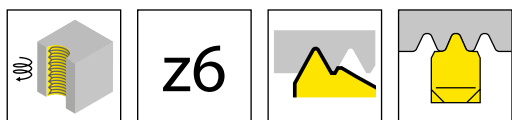
G

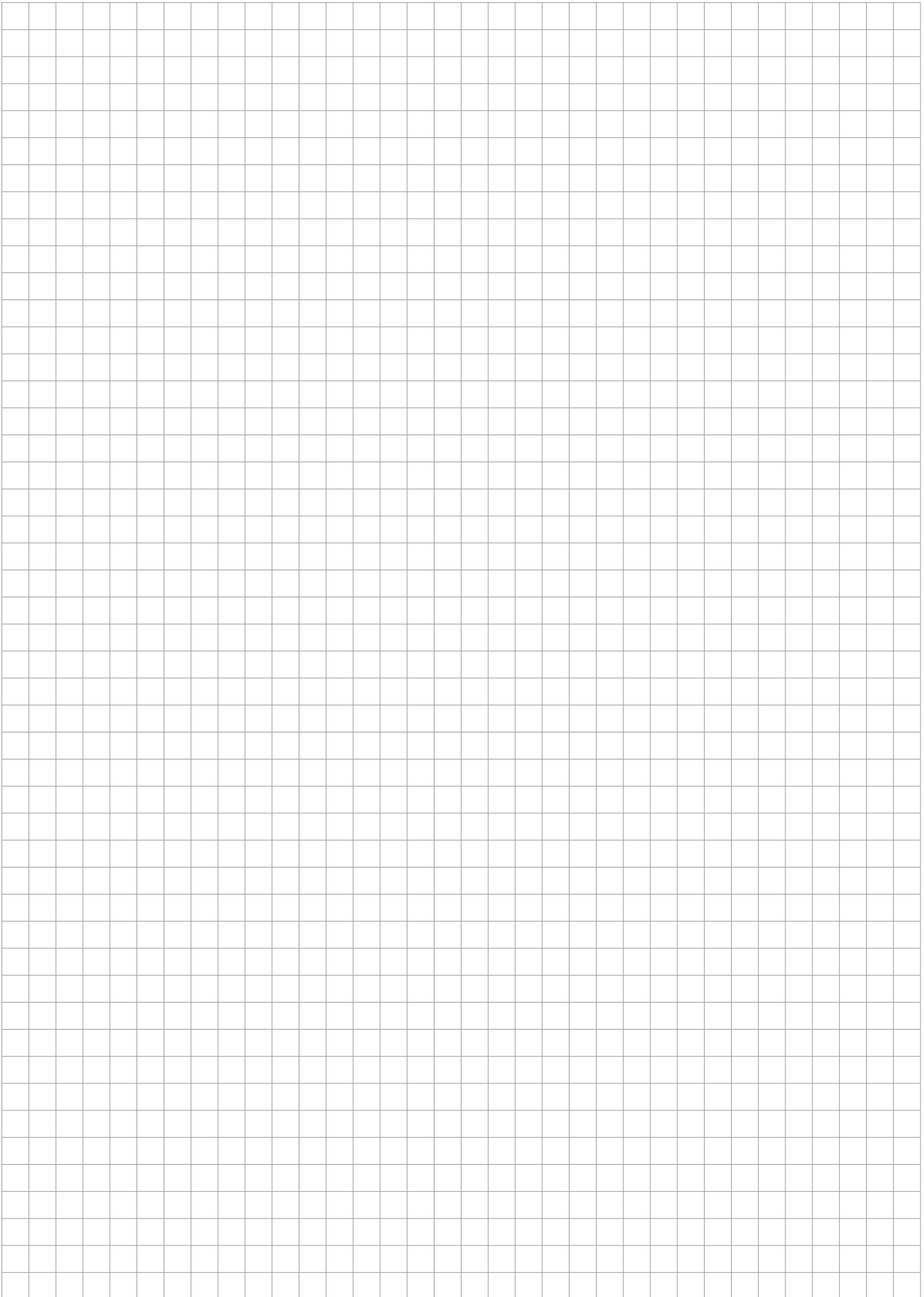

Übersicht
Overview

Seite/Page
298

Frälerschaft
Milling shank
M308

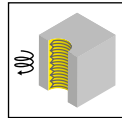

Seite/Page
299

Schneidplatte
Insert
111/308/608

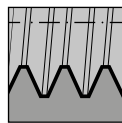

Seite/Page
300-301

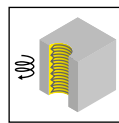

Seite/Page
302-305

G

Achtung:

Beim Nenndurchmesser handelt es sich immer um den größten \emptyset am Gewinde. In der Regel richtet sich die Bezeichnung nach der Größe des Gewindes.

Bsp: M12 x 1 -> Nenndurchmesser 12

Bei Unterschreitung des angegebenen Nenndurchmessers wird durch den Nachschnitt des Werkzeugs kein lehrenhaltiges Gewinde mehr erreicht.

Attention:

The nominal diameter is always the largest \emptyset on the thread. As a rule, the designation is based on the size of the thread.

Example: M12 x 1 -> nominal diameter 12

Recutting of the milling tool will create profile errors if the nominal diameter of the component will be smaller than recommended.

M308



G

**Gewindefräser
(zirkular)**

ab Schneidkreis \varnothing 13,4 mm

**Thread Milling Cutter
(by circular interpolation)**

from cutting edge \varnothing 13,4 mm

Teilprofil, metrisch Typ 111, 308

Partial profile, metric type 111, 308

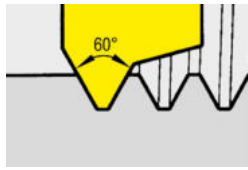

Steigung/Pitch P	0,5	0,75	1,0	1,25	1,5	1,75	2,0	2,5	3,0
Nenn Durchmesser / Nominal diameter									
Typ / type 111 / Ds 13,4									
R/L111.0205.01	≥ 18	≥ 16							
R/L111.0510.01			≥ 18	≥ 18					
R/L111.0815.01					≥ 20	≥ 20			
R/L111.1020.01							≥ 22		
R/L111.1325.01								≥ 24	
Typ / type 308 / Ds 13,2									
308.1325.01								≥ 18	
Typ / type 308 / Ds 15,7									
308.0815.01					≥ 22				
308.0720.01			≥ 20	≥ 20	≥ 20	≥ 20	≥ 20		
308.2530.01								≥ 24	≥ 24

Teilprofil, metrisch Typ 608

Partial profile, metric type 608

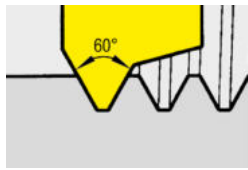

Steigung/Pitch P	0,5	0,75	1,0	1,25	1,5	1,75	2,0	2,5	3,0
Nenn Durchmesser / Nominal diameter									
Typ / type 608 / Ds 13,2									
608.1325.01								≥ 18	
Typ / type 608 / Ds 15,7									
608.0720.01			≥ 20	≥ 20	≥ 20	≥ 20	≥ 20		
608.2530.01								≥ 24	≥ 24

Vollprofil, Whitworth Typ 111, 608

Full profile, Whitworth type 111, 608

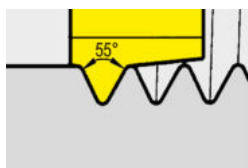

Gg/'' / tpi	19	14
Nenn Durchmesser Nominal diameter		
Typ / type 111 / Ds 13,4		
111.5519.02	≥ 18	
111.5514.02		≥ 21
Gewinde/ Thread		
Typ / type 608 / Ds 13,5		
608.5514.02		G½''/G¾''

Trapezgewinde, metrisch Typ 608

Trapezoidal thread, metric type 608

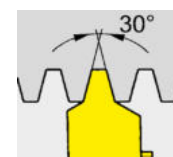

608.1525.01	Tr24x2,5
608.1730.01	Tr24x3
608.2240.01	Tr24x4

Fräuserschaft

Milling shank

M308



Abbildung = rechtsschneidend
Picture = right hand cutting version

Bestellnummer Part number	d	l ₁	l ₂	d ₁	Form	HWS
M308.0012.07A	12	160	-	8	A	308080R • 308080L
M308.1012.02A	12	110	42	9,5	A	308080R • 308080L
M308.1016.01A	16	110	33	9,5	A	308080R • 308080L
M308.1016.02A	16	110	45	9,5	A	308080R • 308080L
M308.1016.03A	16	130	64	9,5	A	308080R • 308080L
M308.1012.02B	12	110	42	9,5	B	308080R • 308080L
M308.1016.01B	16	110	33	9,5	B	308080R • 308080L
M308.1016.02B	16	110	45	9,5	B	308080R • 308080L
M308.1016.03B	16	130	64	9,5	B	308080R • 308080L
M308.1012.02E	12	110	42	9,5	E	308080R • 308080L
M308.1016.01E	16	110	33	9,5	E	308080R • 308080L
M308.1016.02E	16	110	45	9,5	E	308080R • 308080L
M308.1016.03E	16	130	64	9,5	E	308080R • 308080L

Ds siehe Schneidplatten
Ds see inserts

Ersatzteile

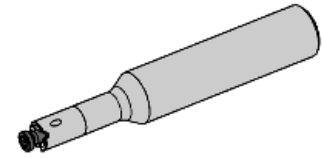
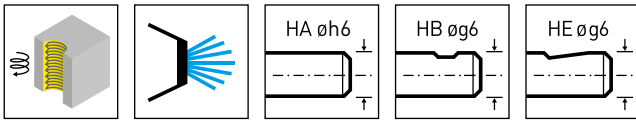
Spare Parts

Fräuserschaft Milling shank	Spannschraube Clamping Screw	TORX PLUS®-Schlüssel TORX PLUS® Wrench
M308...	3.5.12T10EP	T10PL



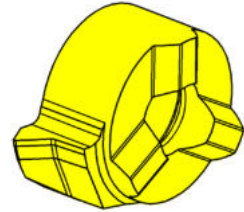
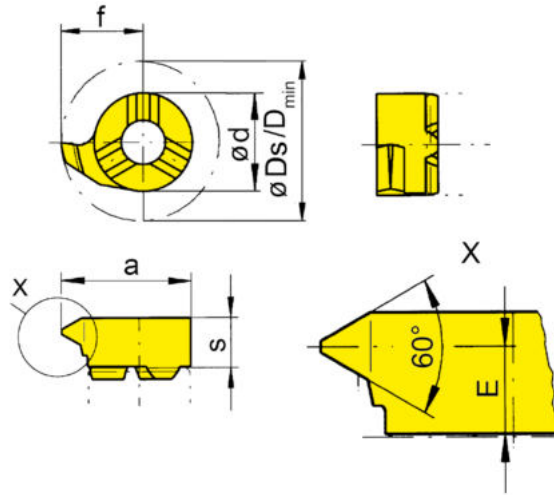

R = rechts wie gezeichnet
R = right hand version shown

L = links spiegelbildlich
L = left hand version

▲ ab Lager
on stock

HM-Sorten
Carbide grades
△ 4 Wochen
4 weeks

Bestellnummer Part number	P	P _{max}	E	s	f	a	d	Ds	Z	D _{min}	HIS	EG55	TH35	TN35
R111.0205.01	0,5	0,75	3,5	4,15	6,7	10,7	8	13,4	1	11	308080R	▲	▲	▲
R111.0510.01	1	1,25	3,3	4,15	6,7	10,7	8	13,4	1	11	308080R	▲	▲	▲
R111.0815.01	1,5	1,75	3,3	4,15	6,7	10,7	8	13,4	1	11	308080R	▲	▲	▲
R111.1020.01	2	2	3	4,15	6,7	10,7	8	13,4	1	11	308080R	▲	▲	▲
L111.0205.01	0,5	0,75	3,5	4,15	6,7	10,7	8	13,4	1	11	308080L	△	△	▲
L111.0510.01	1	1,25	3,3	4,15	6,7	10,7	8	13,4	1	11	308080L	▲	△	▲
L111.0815.01	1,5	1,75	3,3	4,15	6,7	10,7	8	13,4	1	11	308080L	▲	△	▲
L111.1020.01	2	2	3	4,15	6,7	10,7	8	13,4	1	11	308080L	△	△	▲
P	●	●	●											
M	○	●	●											
K	○	●	●											
N	-	●	●											
S	-	●	●											
H	-	-	-											

G

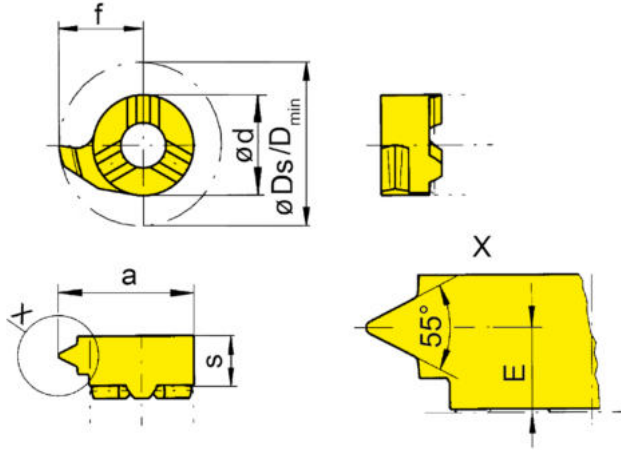

R = rechts wie gezeichnet
R = right hand version shown

L = links spiegelbildlich
L = left hand version

▲ ab Lager
on stock

HM-Sorten
Carbide grades
Δ 4 Wochen
4 weeks

Bestellnummer Part number	TPI	E	s	f	a	d	Ds	D _{min}	HIS	EG55	TA45	TN35
R111.5514.02	14	2,5	4,15	6,7	10,7	8	13,4	11	308080R	▲		▲
R111.5519.02	19	2,9	4,15	6,7	10,7	8	13,4	11	308080R	▲	Δ	▲
L111.5514.02	14	2,5	4,15	6,7	10,7	8	13,4	11	308080L	Δ		▲
L111.5519.02	19	2,9	4,15	6,7	10,7	8	13,4	11	308080L		Δ	▲
P		●	●	●								
M		○	●	●								
K		○	●	●								
N		-	●	●								
S		-	●	●								
H		-	-	-								





Abbildung = rechtsschneidend
Picture = right hand cutting version

▲ ab Lager
on stock

HM-Sorten
Carbide grades

Δ 4 Wochen
4 weeks

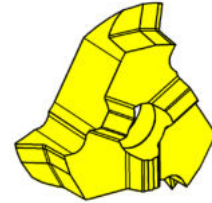
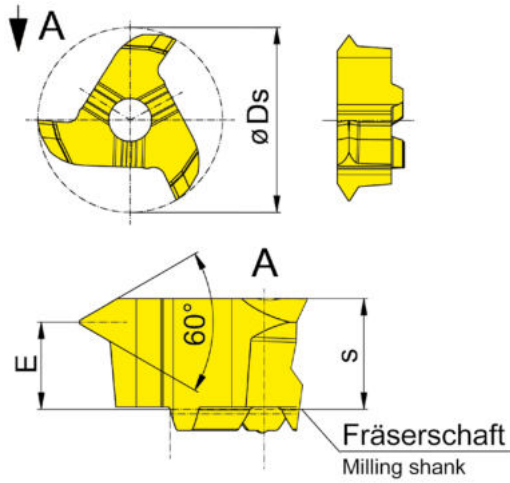
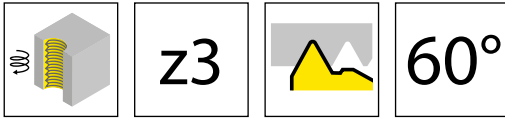
Bestellnummer Part number	P	P _{max}	E	s	Ds	Z	HIS	AS45	TA45	TF45	TI25	TN35
308.1325.01	2,5	2,5	3,3	4,7	13,2	3	308080R	▲	▲			
308.0720.01	1	2	3,3	4,7	15,7	3	308080R	▲			Δ	▲
308.0815.01	1,5	1,5	3,7	4,7	15,7	3	308080R	▲				▲
308.2530.01	2,5	3	2,7	4,7	15,7	3	308080R	▲		Δ	Δ	▲

Hinweis:
308.0815.01 auch zur Herstellung von Gewinde UNF 7/8"-14 geeignet

Note:
308.0815.01 also suitable for production of thread UNF 7/8"-14

	P	M	K	N	S	H
AS45	●	●	●	●	●	-
TA45	●	●	●	●	●	-
TF45	●	●	●	●	●	-
TI25	●	●	●	●	●	-
TN35	●	●	●	●	●	-

G



Abbildung = rechtsschneidend
Picture = right hand cutting version

▲ ab Lager
on stock

HM-Sorten
Carbide grades
Δ 4 Wochen
4 weeks

Bestellnummer Part number	P	P _{max}	E	s	Ds	Z	HIS	AS45	TA45	TI25
608.0720.01	1	2	3,3	4,55	15,7	6	308080R	▲		▲
608.1325.01	2,5	2,5	3,3	4,55	13,2	6	308080R	▲	▲	
608.2530.01	2,5	3	2,9	4,55	15,7	6	308080R	▲		▲
Hinweis: 608.1325.01 auch zur Herstellung von Gewinde UNF 7/8"-14 geeignet								P	●	●
Note: 608.1325.01 also suitable for production of thread UNF 7/8"-14								M	●	●
								K	●	●
								N	○	●
								S	●	●
								H	-	-

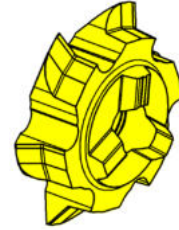
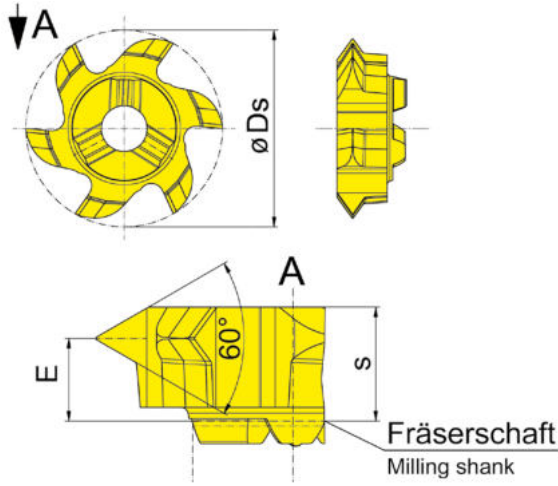
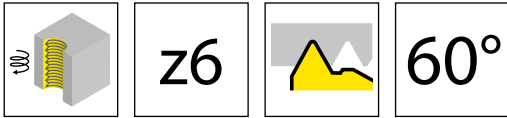



Abbildung = rechtsschneidend
Picture = right hand cutting version

▲ ab Lager
on stock

HM-Sorten
Carbide grades
Δ 4 Wochen
4 weeks

Bestellnummer Part number	TPI	E	s	Ds	HIS	AS45	TA45	TI25
608.5514.02	14	3,2	4,7	13,5	308080R	▲	▲	Δ
						P ●	●	●
						M ●	●	●
						K ●	●	●
						N ○	●	●
						S ●	●	●
						H -	-	-

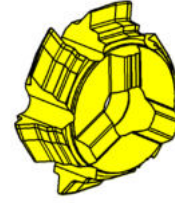
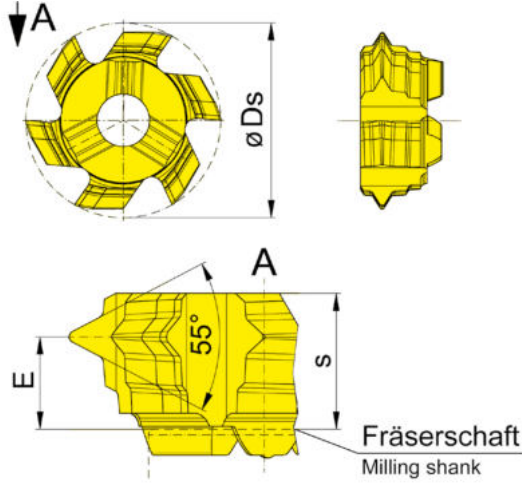
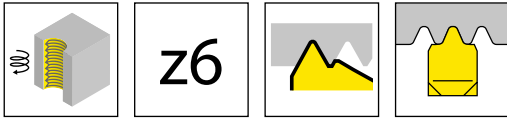
G



Abbildung = rechtsschneidend
Picture = right hand cutting version

HM-Sorten
Carbide grades
▲ ab Lager
on stock
△ 4 Wochen
4 weeks

Bestellnummer Part number	P	s	E	Ds	Z	HIS	EG55
608.1525.01	2,5	4,55	3,56	15,7	6	308080R	▲
608.1730.01	3	4,55	3,4	15,7	6	308080R	▲
608.2240.01	4	4,55	3,16	15,7	6	308080R	▲
	P	●					
	M	o					
	K	o					
	N	-					
	S	-					
	H	-					

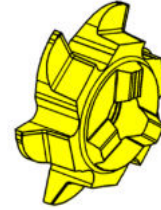
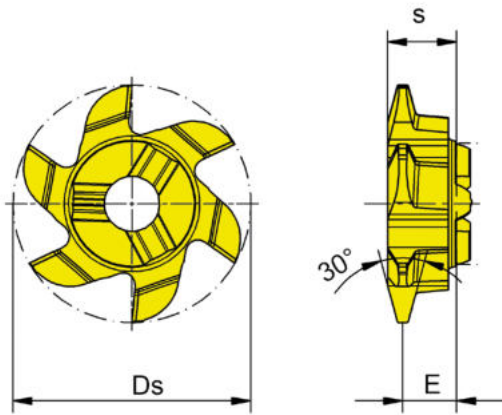
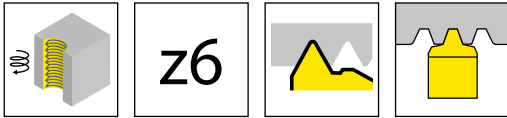

Übersicht
Overview

Seite/Page
308

Frälerschaft
Milling shank
M311

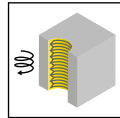

Seite/Page
309

Schneidplatte
Insert
311/611

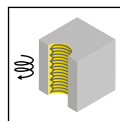

Seite/Page
310-314

G

Achtung:

Beim Nenndurchmesser handelt es sich immer um den größten \emptyset am Gewinde. In der Regel richtet sich die Bezeichnung nach der Größe des Gewindes.

Bsp: M12 x 1 -> Nenndurchmesser 12

Bei Unterschreitung des angegebenen Nenndurchmessers wird durch den Nachschnitt des Werkzeugs kein lehrenhaltiges Gewinde mehr erreicht.

Attention:

The nominal diameter is always the largest \emptyset on the thread. As a rule, the designation is based on the size of the thread.

Example: M12 x 1 -> nominal diameter 12

Recutting of the milling tool will create profile errors if the nominal diameter of the component will be smaller than recommended.

M311



G

**Gewindefräser
(zirkular)**

ab Schneidkreis \varnothing 17,7 mm

**Thread Milling Cutter
(by circular interpolation)**

from cutting edge \varnothing 17,7 mm

Teilprofil, metrisch Typ 311, 611 Partial profile, metric type 311, 611

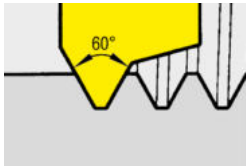

Steigung/Pitch P	0,5	0,75	1,0	1,25	1,5	1,75	2,0	2,5	3,0	3,5
Nenn Durchmesser / Nominal diameter										
Typ / type 311 / Ds 17,7										
311.0515.01	≥ 20	≥ 20	≥ 20	≥ 20	≥ 22					
311.0510.01			≥ 22							
311.0720.01			≥ 22	≥ 22	≥ 22	≥ 22	≥ 22			
311.0815.01					≥ 24					
311.1020.01							≥ 28			
311.1325.01								≥ 34		
311.1630.01									≥ 34	
311.1835.01										≥ 34
311.2535.01								≥ 28	≥ 24	≥ 26
Typ / type 611 / Ds 17,7										
611.0515.01	≥ 20	≥ 20	≥ 20	≥ 20	≥ 22					
611.0720.01			≥ 22	≥ 22	≥ 22	≥ 22	≥ 22			
611.2535.01								≥ 28	≥ 24	≥ 26

Vollprofil, metrisch Typ 311, 611 Full profile, metric type 311, 611



Steigung/Pitch P	1,5	1,75	2,0	2,5	3,0	3,5
Nenn Durchmesser / Nominal diameter						
Typ / type 311, 611 / Ds 17,7						
311.0815.02	≥ 23					
311.0917.02		≥ 24,5				
311.1020.02			≥ 25,5			
311.1325.02				≥ 28,5		
311.1630.02					≥ 32	
311.1835.02						≥ 35
Typ / type 611 / Ds 17,7						
611.0815	≥ 23					

Vollprofil, Whitworth Typ 311 Full profile, Whitworth type 311

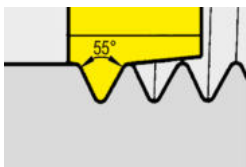

Gg/'' / tpi	14	11
Gewinde / Thread		
Typ / type 311 / Ds 17,7		
311.5514.02	G $\frac{3}{4}$ ''	
311.5511.02		G1''



Abbildung = rechtsschneidend
Picture = right hand cutting version

Bestellnummer Part number	d	l ₁	l ₂	d ₁	Form	HWS
M311.0012.05A	12	130	20	9	A	311090R
M311.1316.01A	16	110	32	13	A	311090R
M311.1316.02A	16	130	45	13	A	311090R
M311.1316.03A	16	145	64	13	A	311090R
M311.1316.01B	16	110	32	13	B	311090R
M311.1316.02B	16	130	45	13	B	311090R
M311.1316.03B	16	145	64	13	B	311090R
M311.1316.01E	16	110	32	13	E	311090R
M311.1316.02E	16	130	45	13	E	311090R
M311.1316.03E	16	145	64	13	E	311090R

Ds siehe Schneidplatten
Ds see inserts

Ersatzteile
Spare Parts

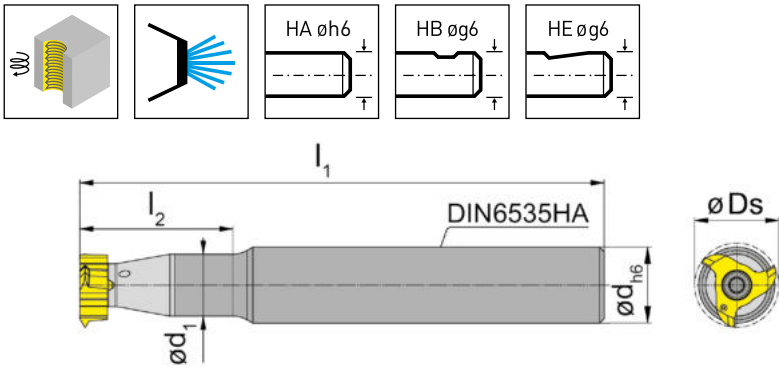
Fräuserschaft Milling shank	Spannschraube Clamping Screw	TORX PLUS®-Schlüssel TORX PLUS® Wrench
M311...	4.14T15P	T15PQ





Abbildung = rechtsschneidend
Picture = right hand cutting version

▲ ab Lager
on stock

HM-Sorten
Carbide grades
△ 4 Wochen
4 weeks

Bestellnummer Part number	P	P _{max}	E	s	D _s	Z	HIS	HM-Sorten Carbide grades		
								AS45	TA45	TN35
311.0515.01	0,5	1,5	4,8	5,95	17,7	3	311090R	▲	▲	
311.0510.01	1	1	5	5,95	17,7	3	311090R	▲		▲
311.0720.01	1	2	4,6	5,95	17,7	3	311090R	▲		▲
311.0815.01	1,5	1,5	4,8	5,95	17,7	3	311090R	▲		▲
311.1020.01	2	2	4,6	5,95	17,7	3	311090R	▲		▲
311.1325.01	2,5	2,5	4,4	5,95	17,7	3	311090R	▲		▲
311.2535.01	2,5	3,5	3,7	5,95	17,7	3	311090R	▲		▲
311.1630.01	3	3	4,3	5,95	17,7	3	311090R	▲		▲
311.1835.01	3,5	3,5	4,1	5,95	17,7	3	311090R	▲		▲
	P							●	●	●
	M							●	●	●
	K							●	●	●
	N							○	●	●
	S							●	●	●
	H							-	-	-

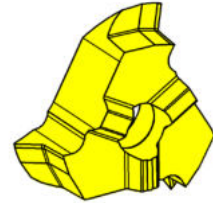
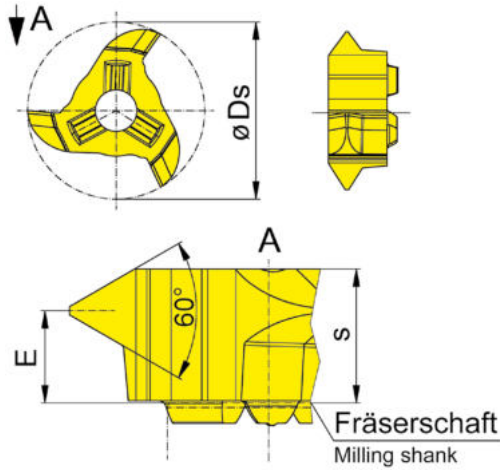
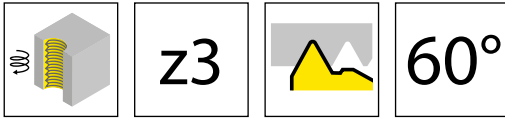
G



Abbildung = rechtsschneidend
Picture = right hand cutting version

▲ ab Lager
on stock

HM-Sorten
Carbide grades
Δ 4 Wochen
4 weeks

Bestellnummer Part number	P	E	s	Ds	HIS	AS45	TN35
311.0815.02	1,5	4,8	5,95	17,7	311090R	▲	▲
311.1020.02	2	4,6	5,95	17,7	311090R	▲	▲
311.1325.02	2,5	4,4	5,95	17,7	311090R	▲	Δ
311.1630.02	3	4,3	5,95	17,7	311090R	▲	▲
311.1835.02	3,5	4,1	5,95	17,7	311090R	▲	▲
						P ● ●	
						M ● ●	
						K ● ●	
						N ○ ●	
						S ● ●	
						H - -	

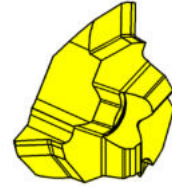
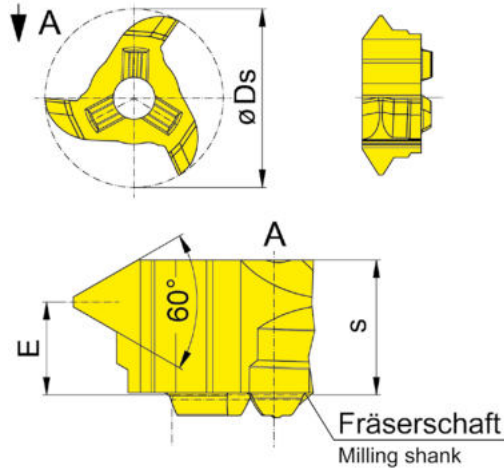
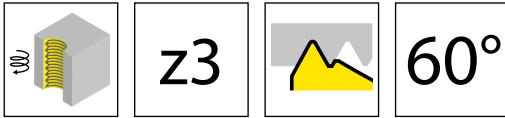



Abbildung = rechtsschneidend
Picture = right hand cutting version

▲ ab Lager
on stock

HM-Sorten
Carbide grades
Δ 4 Wochen
4 weeks

Bestellnummer Part number	TPI	E	s	Ds	HIS	AS45	TA45	TI25	TN35
311.5511.02	11	4	5,95	17,7	311090R	▲	Δ	Δ	▲
311.5514.02	14	4,35	5,95	17,7	311090R	▲	Δ	▲	▲
P	●	●	●	●		●	●	●	●
M	●	●	●	●		●	●	●	●
K	●	●	●	●		●	●	●	●
N	○	○	○	○		○	○	○	○
S	●	●	●	●		●	●	●	●
H	-	-	-	-		-	-	-	-

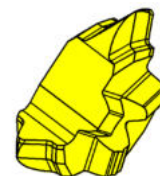
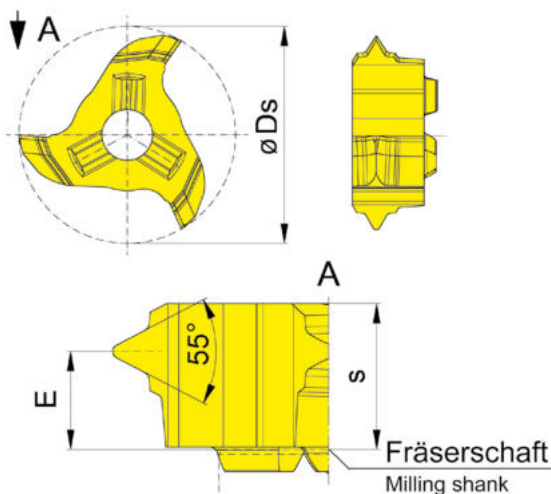
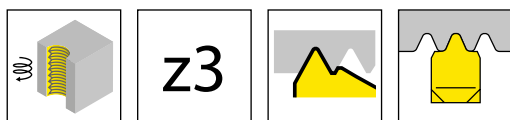
G



Abbildung = rechtsschneidend
Picture = right hand cutting version

▲ ab Lager
on stock

HM-Sorten
Carbide grades

Δ 4 Wochen
4 weeks

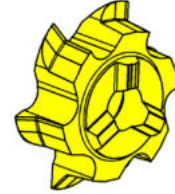
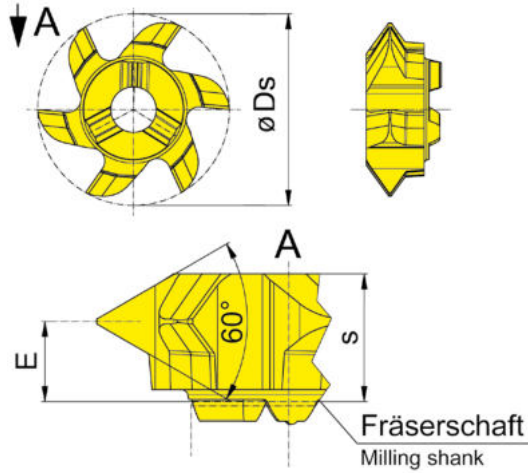
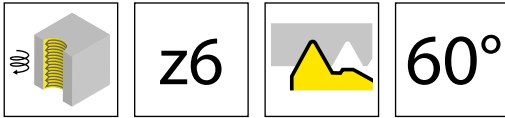
Bestellnummer Part number	P	P _{max}	E	s	Ds	Z	HIS	AS45	TA45	TI25
611.0515.01	0,5	1,5	4,8	5,75	17,7	6	311090R	▲	▲	▲
611.0720.01	1	2	4,6	5,75	17,7	6	311090R	▲	▲	▲
611.2535.01	2,5	3,5	3,7	5,75	17,7	6	311090R	▲	▲	▲
Hinweis: 611.2535.01 auch zur Herstellung von Gewinde UNF 1 1/4"-12, 1 1/8"-12 und 1 5/8"-12 geeignet								P ●	●	●
Note: 611.2535.01 also suitable for production of thread UNF 1 1/4"-12, 1 1/8"-12 and 1 5/8"-12								M ●	●	●
								K ●	●	●
								N ○	●	●
								S ●	●	●
								H -	-	-





Abbildung = rechtsschneidend
Picture = right hand cutting version

▲ ab Lager
on stock

HM-Sorten
Carbide grades
Δ 4 Wochen
4 weeks

Bestellnummer Part number	P	E	s	Ds	Z	HIS	AS45
611.0815.02	1,5	4,8	5,95	17,7	6	311090R	▲
	P ●						
	M ●						
	K ●						
	N ○						
	S ●						
	H -						

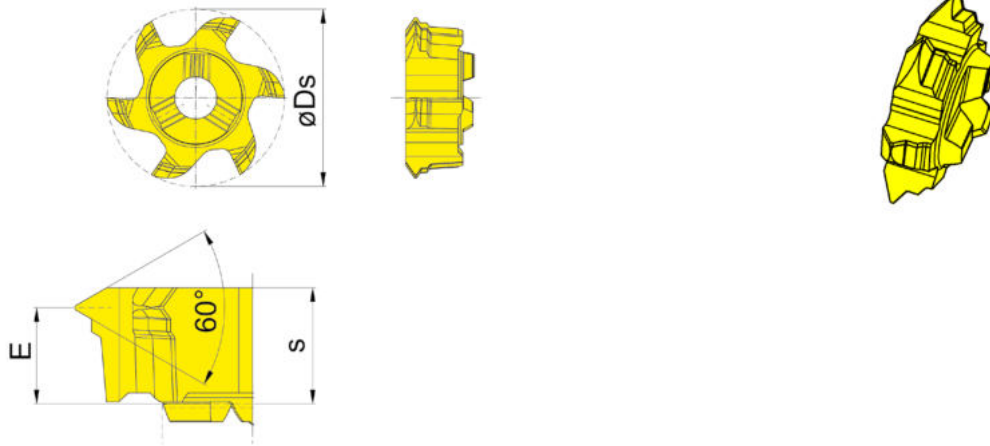
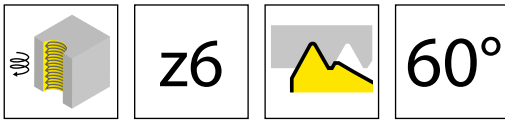
G

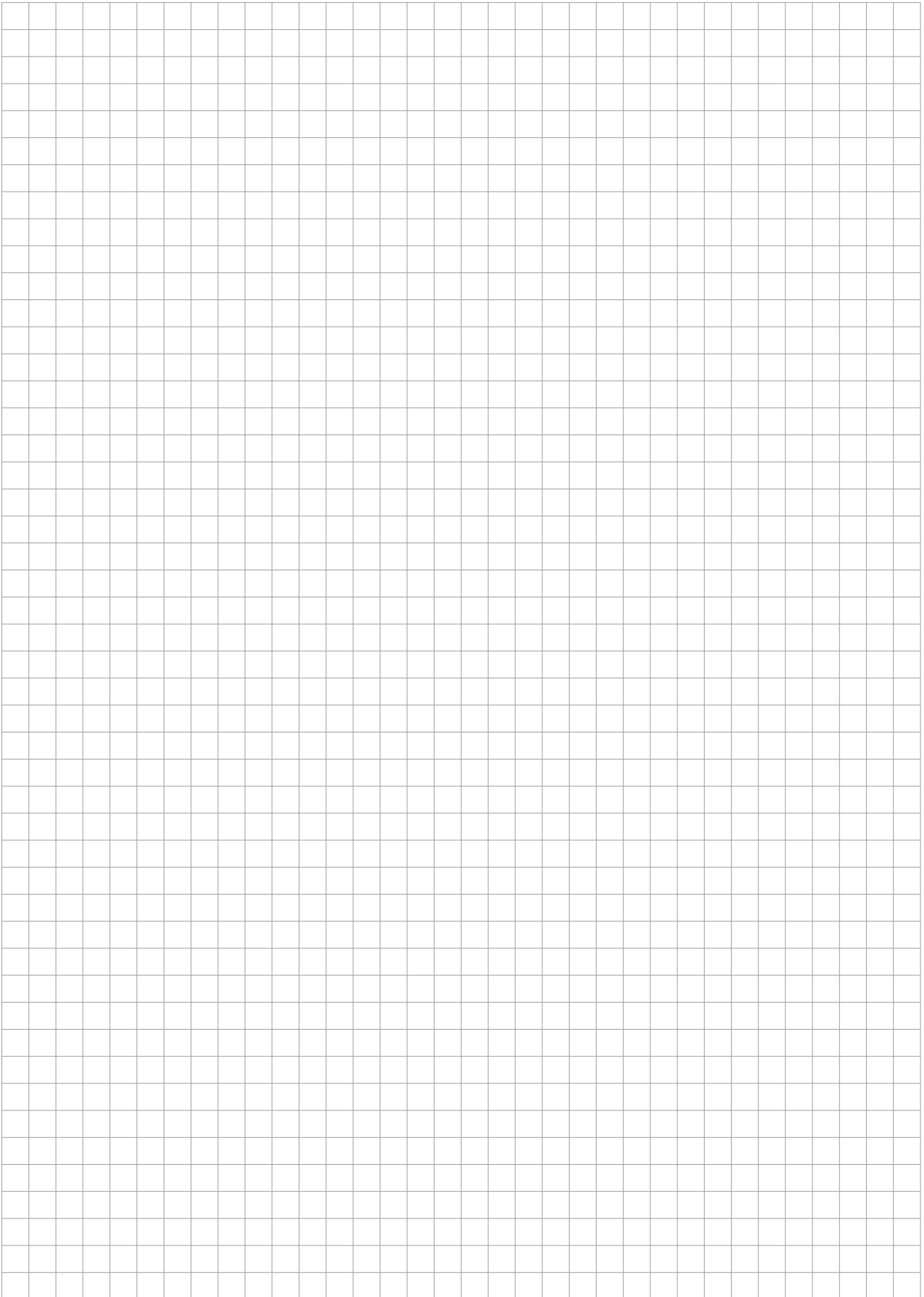

Übersicht
Overview

Seite/Page
318

Frälerschaft
Milling shank
M313

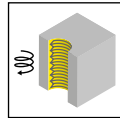

Seite/Page
319-320

Schneidplatte
Insert
313/613

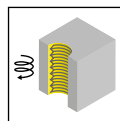

Seite/Page
321-325

G

Achtung:

Beim Nenndurchmesser handelt es sich immer um den größten \emptyset am Gewinde. In der Regel richtet sich die Bezeichnung nach der Größe des Gewindes.

Bsp: M12 x 1 -> Nenndurchmesser 12

Bei Unterschreitung des angegebenen Nenndurchmessers wird durch den Nachschnitt des Werkzeugs kein lehrenhaltiges Gewinde mehr erreicht.

Attention:

The nominal diameter is always the largest \emptyset on the thread. As a rule, the designation is based on the size of the thread.

Example: M12 x 1 -> nominal diameter 12

Recutting of the milling tool will create profile errors if the nominal diameter of the component will be smaller than recommended.

M313



G

**Gewindefräser
(zirkular)**

ab Schneidkreis \varnothing 21,7 mm

**Thread Milling Cutter
(by circular interpolation)**

from cutting edge \varnothing 21,7 mm

Teilprofil, metrisch Typ 313, 613 Partial profile, metric type 313, 613

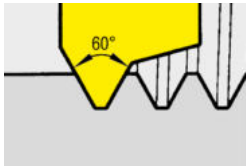

Steigung/Pitch P	1,0	1,25	1,5	1,75	2,0	2,5	3,0	3,5	4,0	4,5
Nenn Durchmesser / Nominal diameter										
Typ / type 313 / Ds 21,7										
313.0720.01	≥ 27	≥ 26	≥ 26	≥ 26	≥ 26					
313.0815.01			≥ 30							
313.1020.01					≥ 32					
313.1630.01							≥ 36			
313.1835.01								≥ 36		
313.2140.01									≥ 36	
313.2445.01										≥ 38
313.2545.01						≥ 33	≥ 32	≥ 30	≥ 30	≥ 30
Typ / type 613 / Ds 21,7										
613.0720.01	≥ 27	≥ 26	≥ 26	≥ 26	≥ 26					
613.2545.01						≥ 33	≥ 32	≥ 30	≥ 30	≥ 30

Vollprofil, metrisch Typ 313 Full profile, metric type 313



Steigung/Pitch P	1,5	2,0	3,0	3,5	4,0	4,5
Nenn Durchmesser / Nominal diameter						
Typ / type 313 / Ds 21,7						
313.0815.02	≥ 27					
313.1020.02		≥ 30				
313.1630.02			≥ 37			
313.1835.02				≥ 40		
313.2140.02					≥ 44	
313.2445.02						≥ 48

Vollprofil, Whitworth Typ 313, 613 Full profile, Whitworth type 313, 613

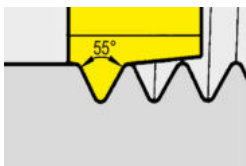

Gg/" / tpi	11	8	6
Nenn Durchmesser Nominal diameter			
Typ / type 313 / Ds 21,7			
313.5508.02		≥ 40	
313.5506.02			≥ 48
Gewinde / Thread			
Typ / type 313 / Ds 21,7			
313.5511.02	G1"		
Typ / type 613 / Ds 21,7			
613.5511.02	G1"		



Abbildung = rechtsschneidend
Picture = right hand cutting version

Bestellnummer Part number	d	l ₁	l ₂	d ₁	Form	HWS
M313.1620.01A	20	110	45	16	A	313113R • 313113L
M313.1620.02A	20	130	65	16	A	313113R • 313113L
M313.1620.03A	20	160	85	16	A	313113R • 313113L
M313.1620.01B	20	110	45	16	B	313113R • 313113L
M313.1620.02B	20	130	65	16	B	313113R • 313113L
M313.1620.03B	20	160	85	16	B	313113R • 313113L
M313.1620.01E	20	110	45	16	E	313113R • 313113L
M313.1620.02E	20	130	65	16	E	313113R • 313113L
M313.1620.03E	20	160	85	16	E	313113R • 313113L

Ds siehe Schneidplatten
Ds see inserts

Ersatzteile
Spare Parts

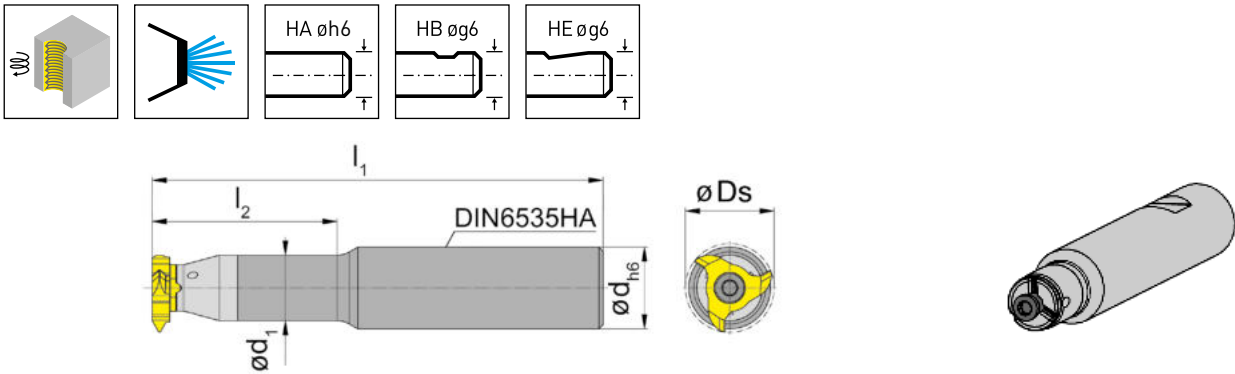
Frälerschaft Milling shank	Spannschraube Clamping Screw	TORX PLUS®-Schlüssel TORX PLUS® Wrench
M313...	5.14T20P	T20PQ





Abbildung = rechtsschneidend
Picture = right hand cutting version

Bestellnummer Part number	d	l ₁	l ₂	d ₁	Form	HWS
M313.0016.07A	16	160	20	12	A	313113R • 313113L

Ds siehe Schneidplatten
Ds see inserts

G

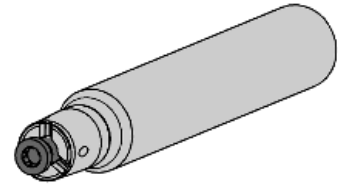
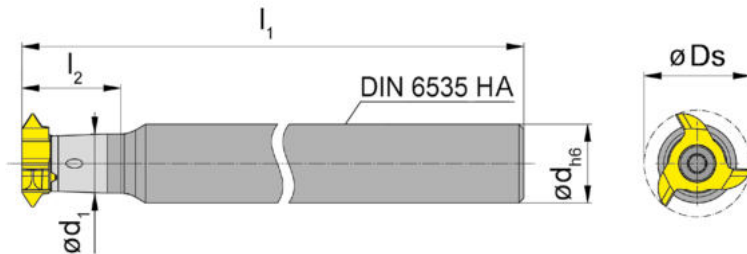
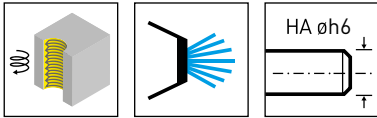
Ersatzteile
Spare Parts

Fräserschaft Milling shank	Spannschraube Clamping Screw	TORX PLUS®-Schlüssel TORX PLUS® Wrench
M313.0016.07A	5.14T20P	T20PQ



Abbildung = rechtsschneidend
Picture = right hand cutting version

▲ ab Lager
on stock

HM-Sorten
Carbide grades

△ 4 Wochen
4 weeks

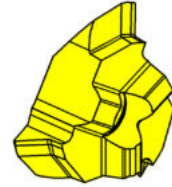
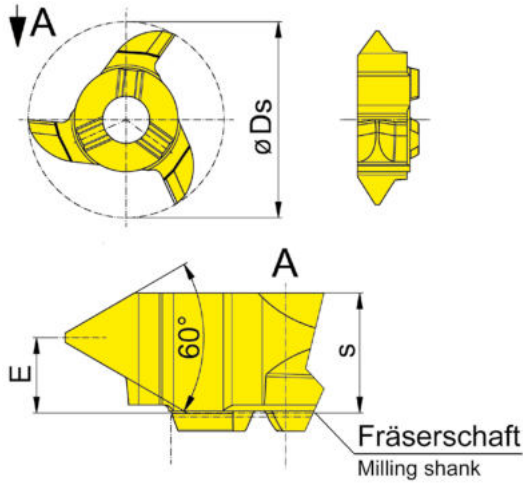
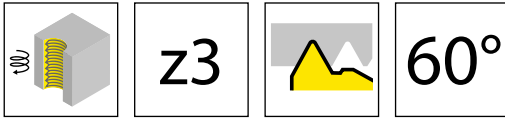
Bestellnummer Part number	P	P _{max}	E	s	D _s	Z	HIS	AS45	EG55	TF45	TN35	
313.0720.01	1	2	4,6	5,9	21,7	3	313113R	▲	▲		▲	
313.0815.01	1,5	1,5	4,8	5,9	21,7	3	313113R	▲	▲		▲	
313.1020.01	2	2	4,6	5,9	21,7	3	313113R	▲	▲		▲	
313.1630.01	3	3	4,3	5,9	21,7	3	313113R	▲	▲		▲	
313.1835.01	3,5	3,5	4,1	5,9	21,7	3	313113R	▲	▲		△	
313.2140.01	4	4	3,9	5,9	21,7	3	313113R	▲	▲	△	▲	
313.2445.01	4,5	4,5	3,7	5,9	21,7	3	313113R	▲	▲		▲	
313.2545.01	2,5	4,5	3,7	5,9	21,7	3	313113R	▲	▲		▲	
Hinweis: 313.1020.01 auch zur Herstellung von Gewinde UNF 1 1/4"-12, 1 1/8"-12 und 1 5/8"-12 geeignet								P	●	●	●	●
Note: 313.1020.01 also suitable for production of thread UNF 1 1/4"-12, 1 1/8"-12 and 1 5/8"-12								M	●	○	●	●
								K	●	○	●	●
								N	○	-	●	●
								S	●	-	●	●
								H	-	-	-	-





Abbildung = rechtsschneidend
Picture = right hand cutting version

▲ ab Lager
on stock

HM-Sorten
Carbide grades
△ 4 Wochen
4 weeks

Bestellnummer Part number	P	E	s	Ds	Z	HIS	AS45	EG55	TN35
313.0815.02	1,5	4,8	5,9	21,7	3	313113R	▲	▲	▲
313.1020.02	2	4,6	5,9	21,7	3	313113R	▲	▲	▲
313.1630.02	3	4,3	5,9	21,7	3	313113R	▲	▲	▲
313.1835.02	3,5	4,1	5,9	21,7	3	313113R	▲	▲	▲
313.2140.02	4	3,9	5,9	21,7	3	313113R	▲	▲	▲
313.2445.02	4,5	3,8	5,9	21,7	3	313113R	▲	▲	▲
							P ●	●	●
							M ●	○	●
							K ●	○	●
							N ○	-	●
							S ●	-	●
							H -	-	-

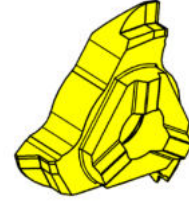
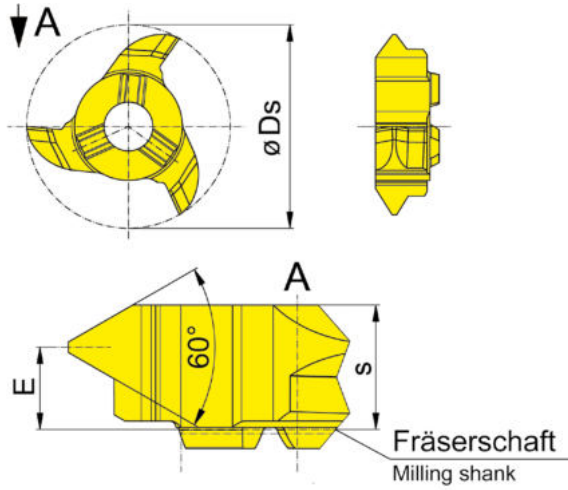
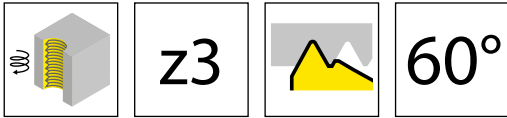
G



Abbildung = rechtsschneidend
Picture = right hand cutting version

▲ ab Lager
on stock

HM-Sorten
Carbide grades
Δ 4 Wochen
4 weeks

Bestellnummer Part number	TPI	E	s	Ds	HIS	AS45	EG55	TN35
313.5506.02	6	3	5,9	21,7	313113R	▲	▲	Δ
313.5508.02	8	3,6	5,9	21,7	313113R	▲	▲	▲
313.5511.02	11	4	5,9	21,7	313113R	▲	▲	▲
						P ●	●	●
						M ●	○	●
						K ●	○	●
						N ○	-	●
						S ●	-	●
						H -	-	-

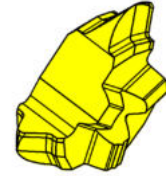
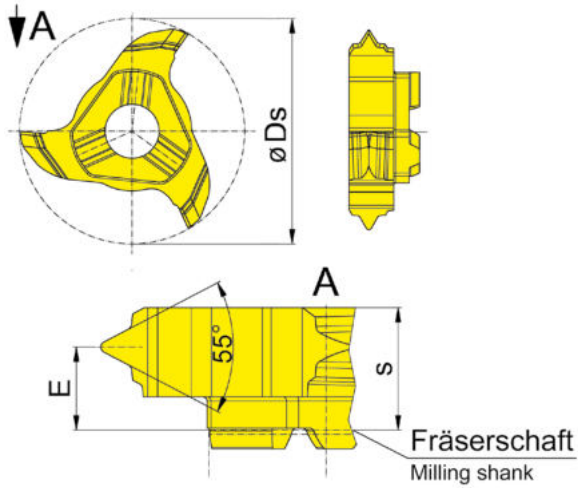
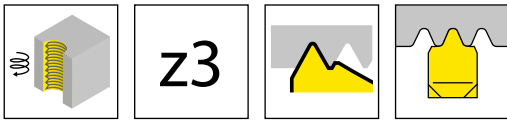



Abbildung = rechtsschneidend
Picture = right hand cutting version

▲ ab Lager
on stock

HM-Sorten
Carbide grades
△ 4 Wochen
4 weeks

Bestellnummer Part number	P	P _{max}	E	s	D _s	Z	HIS	AS45	EG55	TI25
613.0720.01	1	2	4,6	5,6	21,7	6	313113R	▲	△	▲
613.2545.01	2,5	4,5	3,7	5,75	21,7	6	313113R	▲	▲	▲
P	●	●	●	●	●	●	●	●	●	●
M	●	○	●	●	●	●	●	●	○	●
K	●	○	●	●	●	●	●	●	○	●
N	○	-	●	●	●	●	●	○	-	●
S	●	-	●	●	●	●	●	●	-	●
H	-	-	-	-	-	-	-	-	-	-

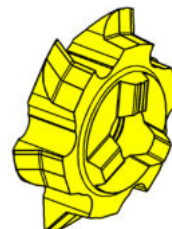
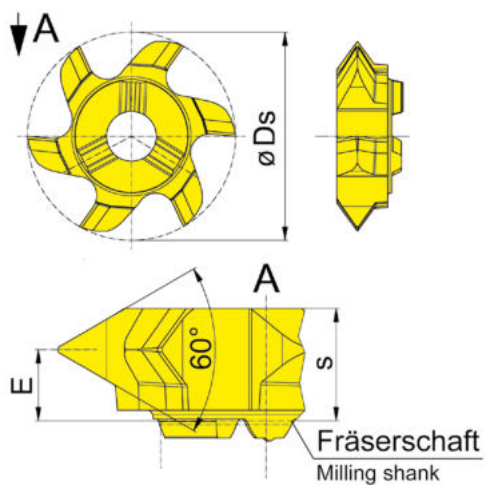
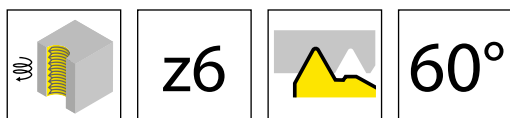
G



Abbildung = rechtsschneidend
Picture = right hand cutting version

▲ ab Lager
on stock

HM-Sorten
Carbide grades

Δ 4 Wochen
4 weeks

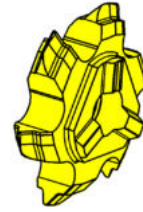
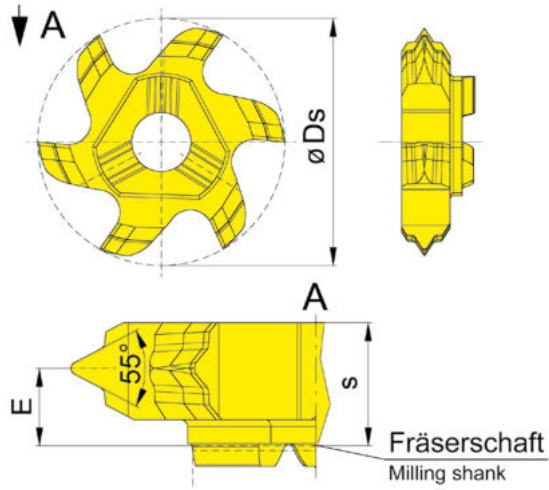
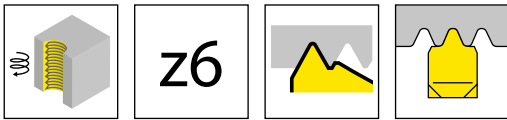
Bestellnummer Part number	TPI	E	s	Ds	HIS	HM-Sorten Carbide grades			
						AS45	EG55	TA45	TI25
613.5511.02	11	3,4	5,4	21,7	313113R	▲	▲	▲	▲
						P	●	●	●
						M	●	○	●
						K	●	○	●
						N	○	-	●
						S	●	-	●
						H	-	-	-



Übersicht
Overview

Seite/Page
328

Frälerschaft
Milling shank
M328/SM328

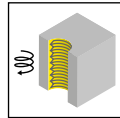

Seite/Page
329-330

Schneidplatte
Insert
328/628

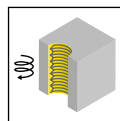

Seite/Page
331-334

G

Achtung:

Beim Nenndurchmesser handelt es sich immer um den größten \emptyset am Gewinde. In der Regel richtet sich die Bezeichnung nach der Größe des Gewindes.

Bsp: M12 x 1 -> Nenndurchmesser 12

Bei Unterschreitung des angegebenen Nenndurchmessers wird durch den Nachschnitt des Werkzeugs kein lehrenhaltiges Gewinde mehr erreicht.

Attention:

The nominal diameter is always the largest \emptyset on the thread. As a rule, the designation is based on the size of the thread.

Example: M12 x 1 -> nominal diameter 12

Recutting of the milling tool will create profile errors if the nominal diameter of the component will be smaller than recommended.

M328



G

**Gewindefräser
(zirkular)**

ab Schneidkreis \varnothing 27,7 mm

**Thread Milling Cutter
(by circular interpolation)**

from cutting edge \varnothing 27,7 mm

Teilprofil, metrisch Typ 328, 628

Partial profile, metric type 328, 628

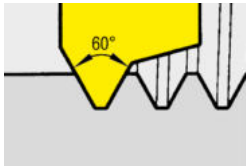

Steigung/Pitch P	1,0	1,25	1,5	1,75	2,0	2,5
------------------	-----	------	-----	------	-----	-----

Nenn Durchmesser / Nominal diameter

Typ / type **328** / Ds 27,7

328.0720.01	≥ 32	≥ 32	≥ 32	≥ 32	≥ 32	
328.1525.01			≥ 34	≥ 34	≥ 34	≥ 34

Typ / type **628** / Ds 27,7

628.1525.01			≥ 34	≥ 34	≥ 34	≥ 34
-------------	--	--	------	------	------	------

Steigung/Pitch P	3,0	3,5	4,0	4,5	5,0	5,5	6,0
------------------	-----	-----	-----	-----	-----	-----	-----

Nenn Durchmesser / Nominal diameter

Typ / type **328** / Ds 27,7

328.3050.01	≥ 40	≥ 38	≥ 38	≥ 38	≥ 38		
328.5060.01					≥ 48	≥ 46	≥ 44

Typ / type **628** / Ds 27,7

628.3050.01	≥ 40	≥ 38	≥ 38	≥ 38	≥ 38		
628.5060.01					≥ 48	≥ 46	≥ 44

Vollprofil, Whitworth Typ 328, 628

Full profile, Whitworth type 328, 628

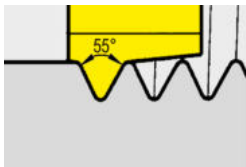

Gg/'' / tpi	11
-------------	----

Gewinde / Thread

Typ / type **328** / Ds 27,7

328.5511.02	G1½''
-------------	-------

Typ / type **628** / Ds 27,7

628.5511.02	G1½''
-------------	-------



Abbildung = rechtsschneidend
Picture = right hand cutting version

Bestellnummer Part number	d	l ₁	Form	HWS
M328.0020.10A	20	250	A	328143R
M328.0020.D.05A	20	145	A	328143R
M328.0020.D.06A	20	160	A	328143R
M328.0020.D.07A	20	180	A	328143R
M328.0020.D.05B	20	145	B	328143R
M328.0020.D.06B	20	160	B	328143R
M328.0020.D.07B	20	180	B	328143R
M328.0020.D.05E	20	145	E	328143R
M328.0020.D.06E	20	160	E	328143R
M328.0020.D.07E	20	180	E	328143R

Ds siehe Schneidplatten
Ds see inserts

Ersatzteile
Spare Parts

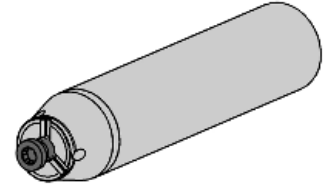
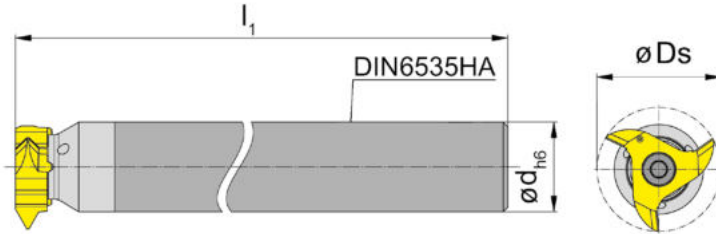
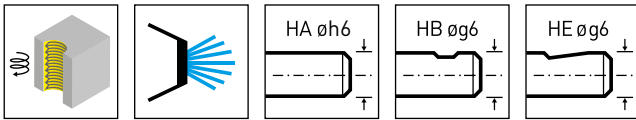
Fräserschaft Milling shank	Spannschraube Clamping Screw	TORX PLUS®-Schlüssel TORX PLUS® Wrench
M328.0020.10A	5.14T20P	T20PQ
M328.0020.D....	5.17T20P	T20PQ





Abbildung = rechtsschneidend
Picture = right hand cutting version

Bestellnummer Part number	d	l ₁	l ₂	d ₁	Form	HWS
SM328.0020.05B	20	130	25	15	B	328143R
SM328.0020.06B	20	145	-	20	B	328143R
SM328.0020.07B	20	160	25	15	B	328143R
SM328.0020.08B	20	200	-	20	B	328143R
SM328.0020.05E	20	130	25	15	E	328143R
SM328.0020.06E	20	145	-	20	E	328143R
SM328.0020.07E	20	160	25	15	E	328143R
SM328.0020.08E	20	200	-	20	E	328143R

Schaftmaterial: Schwermetall (schwingungsarm)
Material of shank: tungsten alloy (giving good vibration resistance)

Ds siehe Schneidplatten
Ds see inserts

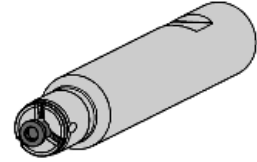
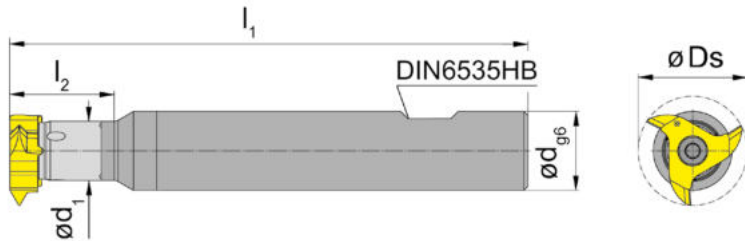
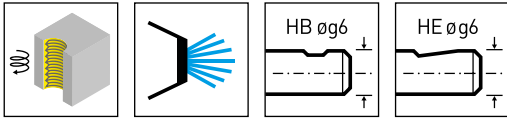
Ersatzteile
Spare Parts

Fräserschaft Milling shank	Spannschraube Clamping Screw	TORX PLUS®-Schlüssel TORX PLUS® Wrench
SM328...	5.17T20P	T20PQ





Abbildung = rechtsschneidend
Picture = right hand cutting version

▲ ab Lager
on stock

HM-Sorten
Carbide grades
Δ 4 Wochen
4 weeks

Bestellnummer Part number	P	P _{max}	E	s	D _s	Z	HIS	AS45	TI25	TN35
328.0720.01	1	2	4,6	5,95	27,7	3	328114R	▲		▲
328.1525.01	1,5	2,5	4,3	5,95	27,7	3	328114R	▲		▲
328.3050.01	3	5	4,8	7,2	27,7	3	328114R	▲	▲	▲
328.5060.01	5	6	4,4	7,2	27,7	3	328114R	▲		▲
P	●	●	●	●	●	●		●	●	●
M	●	●	●	●	●	●		●	●	●
K	●	●	●	●	●	●		●	●	●
N	○	○	○	○	○	○		○	○	○
S	●	●	●	●	●	●		●	●	●
H	-	-	-	-	-	-		-	-	-

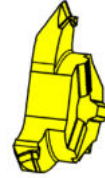
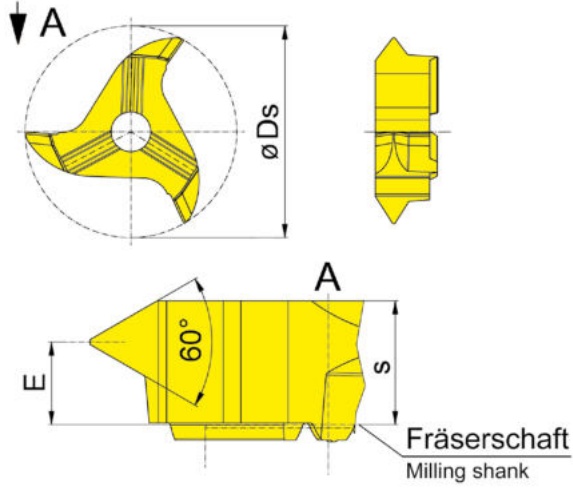
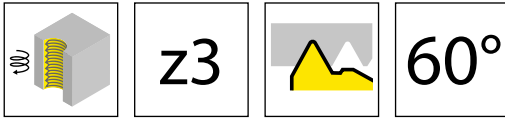



Abbildung = rechtsschneidend
Picture = right hand cutting version

▲ ab Lager
on stock

HM-Sorten
Carbide grades
Δ 4 Wochen
4 weeks

Bestellnummer Part number	TPI	E	s	Ds	HIS	AS45
328.5511.02	11	3,9	5,95	27,7	328114R	▲
						P ●
						M ●
						K ●
						N ○
						S ●
						H -

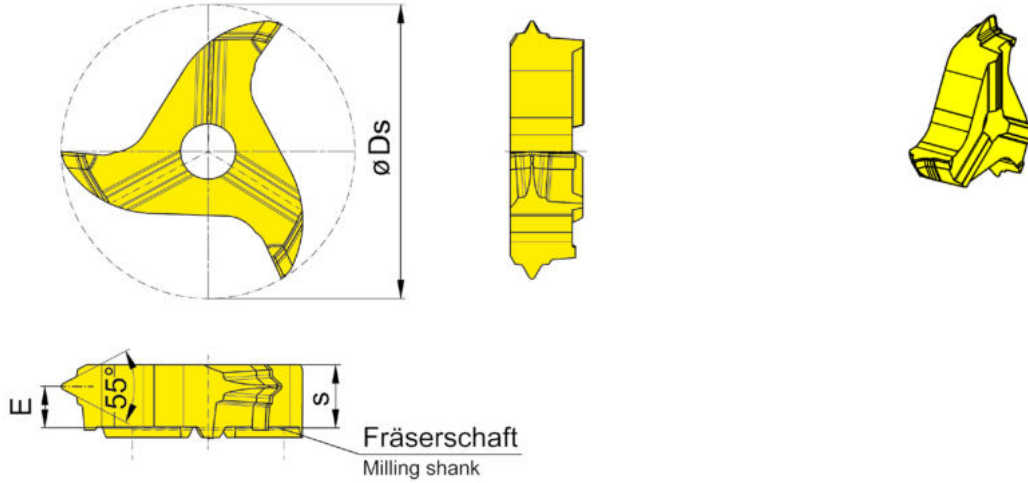
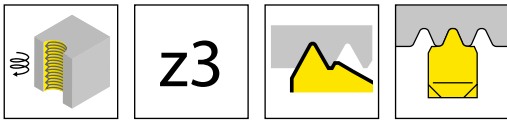
G



Abbildung = rechtsschneidend
Picture = right hand cutting version

▲ ab Lager
on stock

HM-Sorten
Carbide grades
Δ 4 Wochen
4 weeks

Bestellnummer Part number	P	P _{max}	E	s	D _s	Z	HIS	AS45	TI25
628.1525.01	1,5	2,5	4,8	6	27,7	6	328114R	▲	▲
628.3050.01	3	5	3,7	5,75	27,7	6	328114R	▲	▲
628.5060.01	5	6	3,2	5,75	27,7	6	328114R	▲	▲
	P	●	●					●	●
	M	●	●					●	●
	K	●	●					●	●
	N	○	●					○	●
	S	●	●					●	●
	H	-	-					-	-

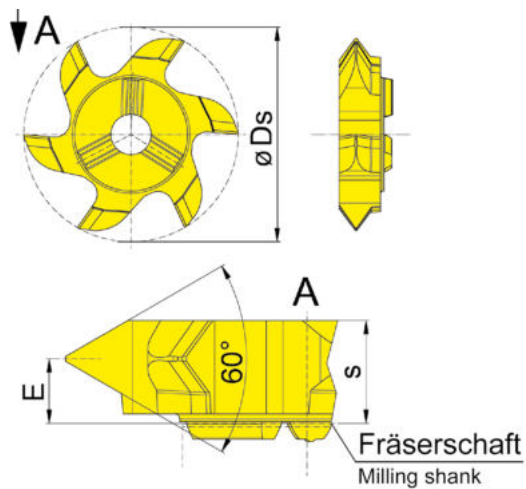
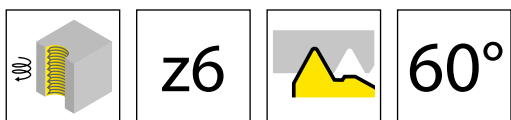



Abbildung = rechtsschneidend
Picture = right hand cutting version

▲ ab Lager
on stock

HM-Sorten
Carbide grades
Δ 4 Wochen
4 weeks

Bestellnummer Part number	TPI	E	s	Ds	HIS	AS45
628.5511.02	11	3,9	5,85	27,7	328114R	▲
						P ●
						M ●
						K ●
						N ○
						S ●
						H -

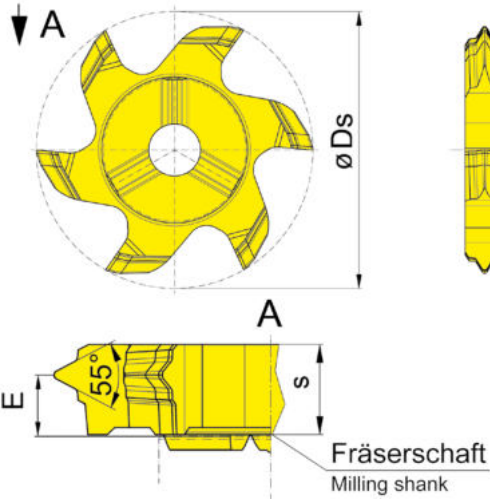
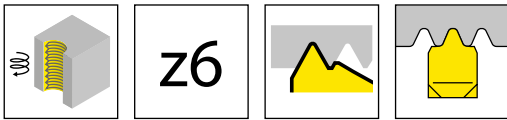
G

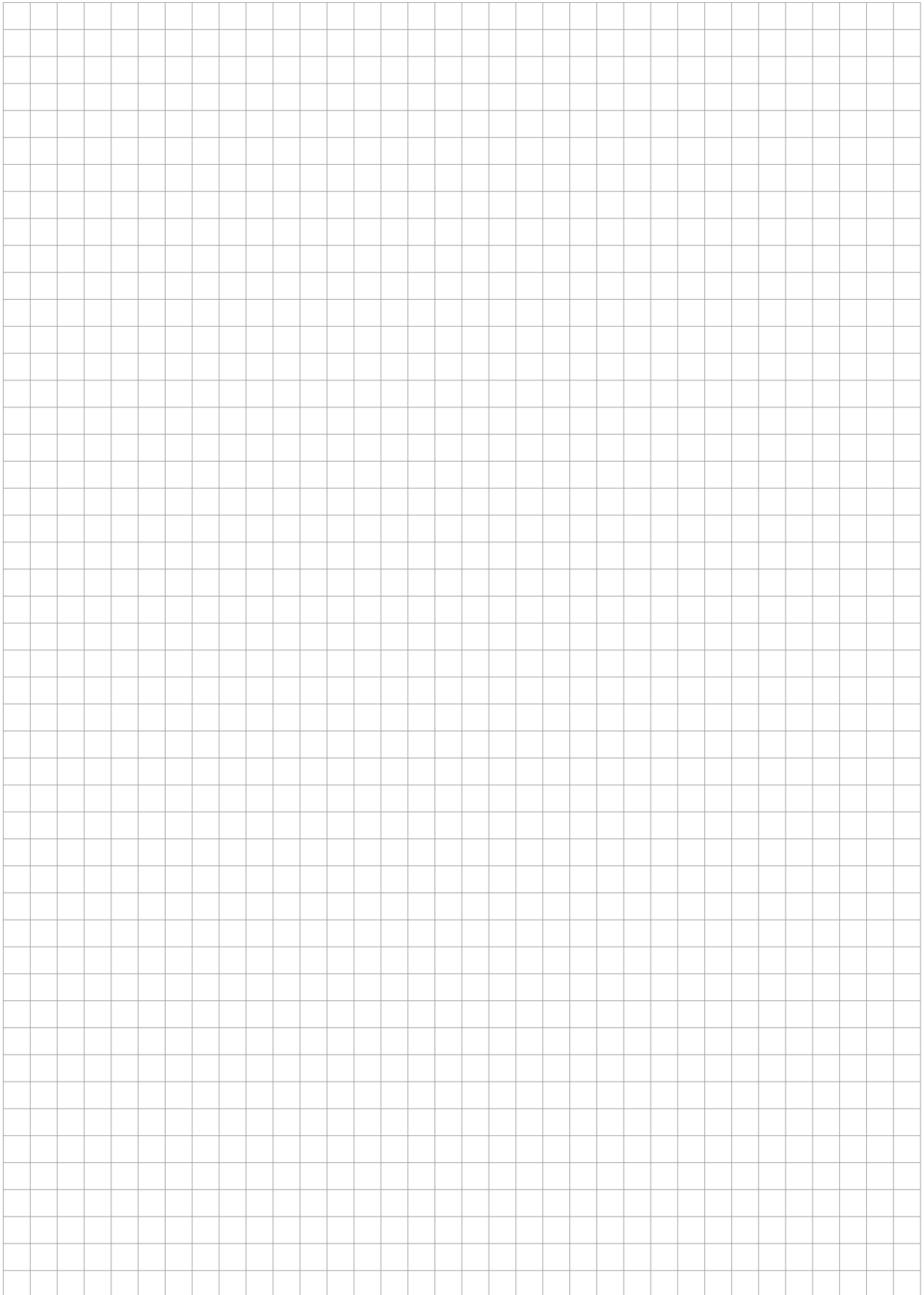

Übersicht
Overview

Seite/Page
338

Frälerschaft
Milling shank
M332

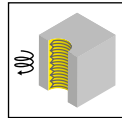

Seite/Page
339

Schneidplatte
Insert
632

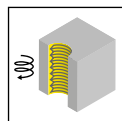

Seite/Page
340

G

Achtung:

Beim Nenndurchmesser handelt es sich immer um den größten \emptyset am Gewinde. In der Regel richtet sich die Bezeichnung nach der Größe des Gewindes.

Bsp: M12 x 1 -> Nenndurchmesser 12

Bei Unterschreitung des angegebenen Nenndurchmessers wird durch den Nachschnitt des Werkzeugs kein lehrenhaltiges Gewinde mehr erreicht.

Attention:

The nominal diameter is always the largest \emptyset on the thread. As a rule, the designation is based on the size of the thread.

Example: M12 x 1 -> nominal diameter 12

Recutting of the milling tool will create profile errors if the nominal diameter of the component will be smaller than recommended.

M332



G

**Gewindefräser
(zirkular)**

ab Schneidkreis \varnothing 31,7 mm

**Thread Milling Cutter
(by circular interpolation)**

from cutting edge \varnothing 31,7 mm

Teilprofil, metrisch Typ 632
 Partial profile, metric type 632

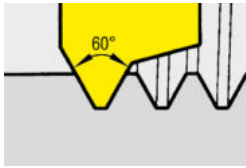

Steigung/Pitch P	2,5	3,0	3,5	4,0	4,5	5,0	5,5	6,0
Nenndurchmesser / Nominal diameter								
Typ / type 632 / Ds 31,7								
632.2545.01	≥ 42	≥ 42	≥ 46	≥ 42	≥ 42			
632.4060.01				≥ 46	≥ 46	≥ 46	≥ 46	≥ 46





Abbildung = rechtsschneidend
Picture = right hand cutting version

Bestellnummer Part number	d	l ₁	l ₂	d ₁	Form	HWS
M332.2325.06A	25	160	95	23,5	A	332143R
M332.2325.07A	25	180	115	23,5	A	332143R
M332.2325.08A	25	200	135	23,5	A	332143R
M332.2325.09A	25	250	185	23,5	A	332143R

Ds siehe Schneidplatten
Ds see inserts

Ersatzteile
Spare Parts

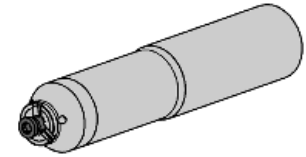
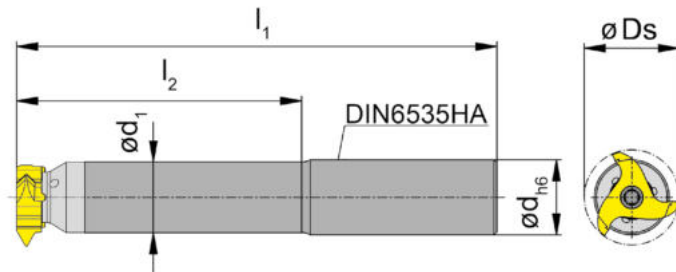
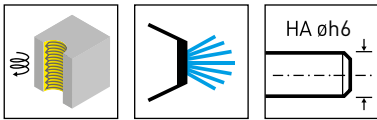
Fräuserschaft Milling shank	Spannschraube Clamping Screw	TORX PLUS®-Schlüssel TORX PLUS® Wrench
M332...	5.17T20P	T20PQ





Abbildung = rechtsschneidend
Picture = right hand cutting version

▲ ab Lager
on stock

HM-Sorten
Carbide grades
Δ 4 Wochen
4 weeks

Bestellnummer Part number	P	P _{max}	E	s	Ds	Z	HIS	AS45	TI25
632.2545.01	2,5	4,5	3,7	5,8	31,7	6	332143R	▲	▲
632.4060.01	4	6	3,2	5,8	31,7	6	332143R	▲	▲
	P	●	●						
	M	●	●						
	K	●	●						
	N	○	●						
	S	●	●						
	H	-	-						

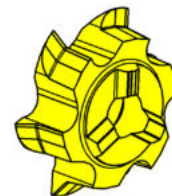
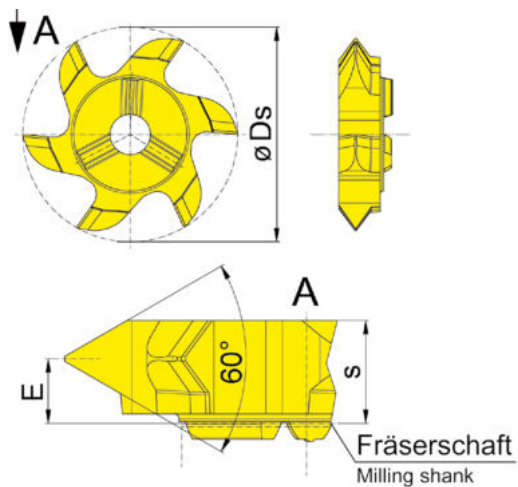
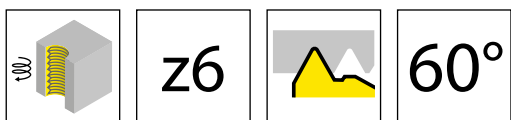
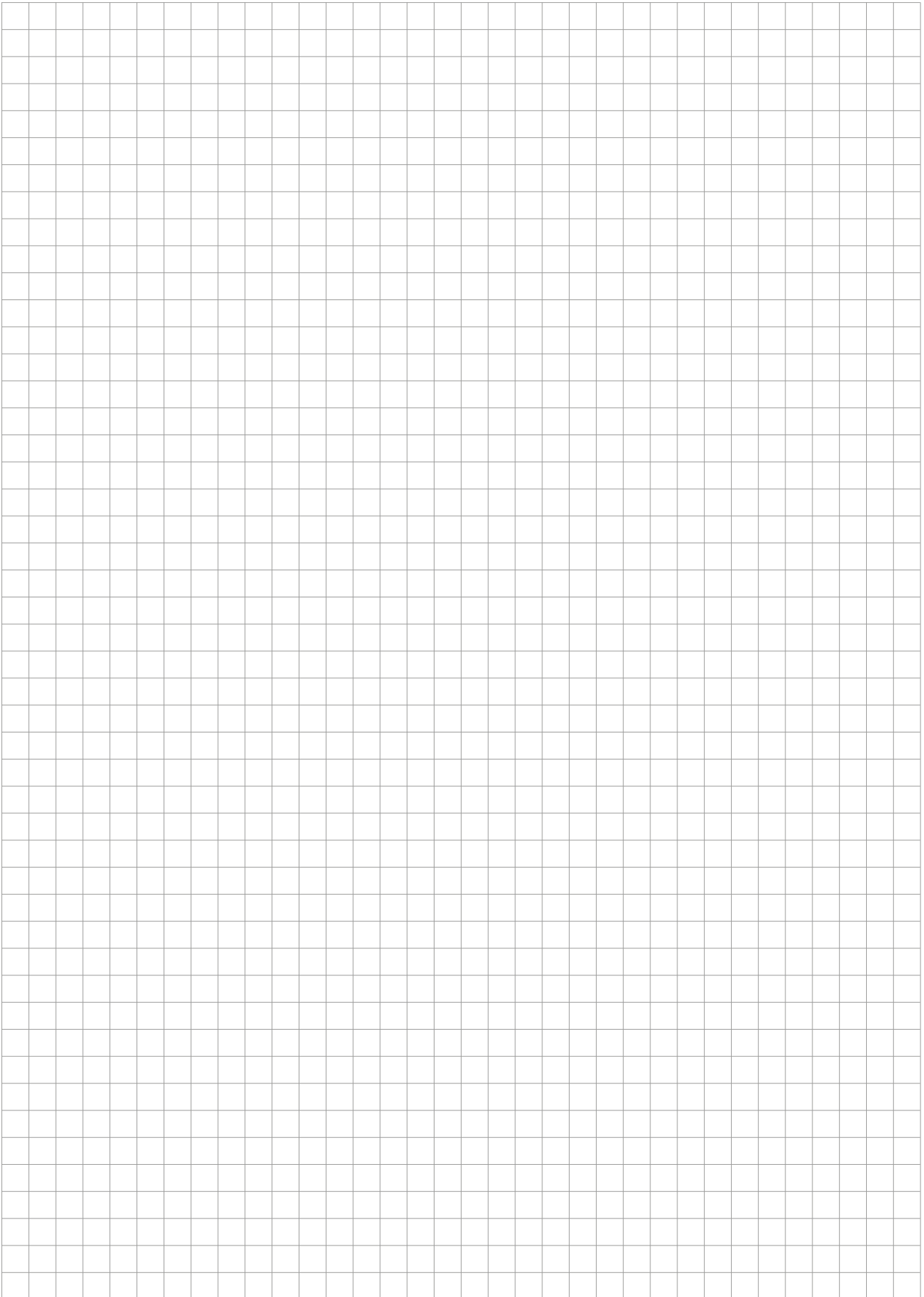

Übersicht
Overview

Seite/Page
344

Schaftfräser
End Mill
M275

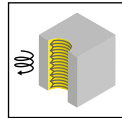

Seite/Page
345

Messerkopf
Milling cutter
M275

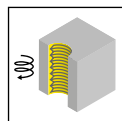

Seite/Page
346

Wendeschneidplatte
Indexable insert
RS275

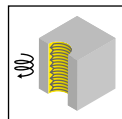

Seite/Page
347

G

Achtung:

Beim Nenndurchmesser handelt es sich immer um den größten \emptyset am Gewinde. In der Regel richtet sich die Bezeichnung nach der Größe des Gewindes.

Bsp: M12 x 1 -> Nenndurchmesser 12

Bei Unterschreitung des angegebenen Nenndurchmessers wird durch den Nachschnitt des Werkzeugs kein lehrenhaltiges Gewinde mehr erreicht.

Attention:

The nominal diameter is always the largest \emptyset on the thread. As a rule, the designation is based on the size of the thread.

Example: M12 x 1 -> nominal diameter 12

Recutting of the milling tool will create profile errors if the nominal diameter of the component will be smaller than recommended.

M275



G

**Gewindefräser
(zirkular)**

ab Schneidkreis \varnothing 31 mm

**Thread Milling Cutter
(by circular interpolation)**

from cutting edge \varnothing 31 mm

Teilprofil, metrisch Typ S275 Partial profile, metric type S275

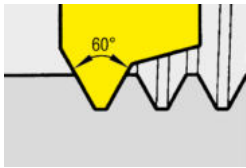

Steigung/Pitch P	1,5	2,0	2,5	3,0	3,5
Nenndurchmesser / Nominal diameter					
Typ / type S275 / Ds 31					
RS275.1535.01	≥ 45				
Typ / type S275 / Ds 38					
RS275.1535.01	≥ 54				
Typ / type S275 / Ds 48					
RS275.1535.01	≥ 70				
Typ / type S275 / Ds 58					
RS275.1535.01	≥ 83				





Abbildung = rechtsschneidend
Picture = right hand cutting version

Bestellnummer Part number	Z	Ds	d	l ₁	λ	HWS
M275.031.D25.3.04A	4	31	25	125	4°	275041R

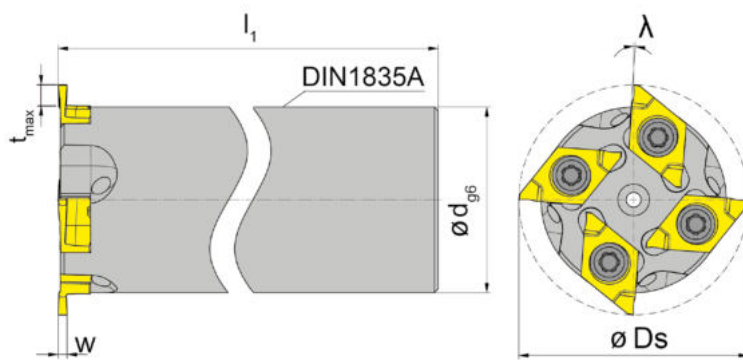
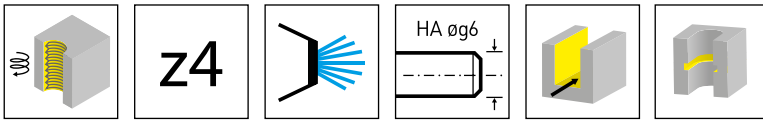

Ersatzteile
Spare Parts

Schaftfräser End Mill	Spannschraube Clamping Screw	TORX PLUS®-Schlüssel TORX PLUS® Wrench
M275.031.D25.3.04A	3.5.10T10P	T10PL



Abbildung = rechtsschneidend
Picture = right hand cutting version

Bestellnummer Part number	Z	Ds	h ₂	h	d ₅	d ₄	d ₃	l ₁	l ₂	b	C	d ₂	HWS
M275.0038.A16.05	5	38	32,7	33	13,5	32	16	18	22,7	8,4	5,6	32	275041R
M275.0048.A22.08	8	48	36,7	37	18,5	40,5	22	20	24,7	10,4	6,3	40,5	275041R
M275.0058.A27.10	10	58	42,2	42,5	22	48	27	22	27,2	12,4	7	50	275041R
M275.0078.A32.14	14	78	49,7	50	33	58	32	25	36,7	14,4	8	70,5	275041R

G

Ersatzteile
Spare Parts

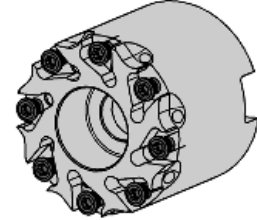
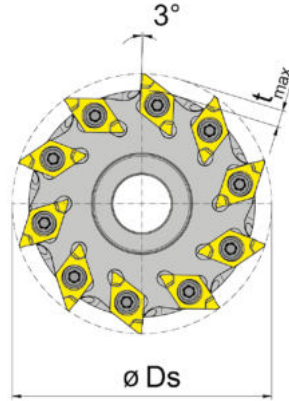
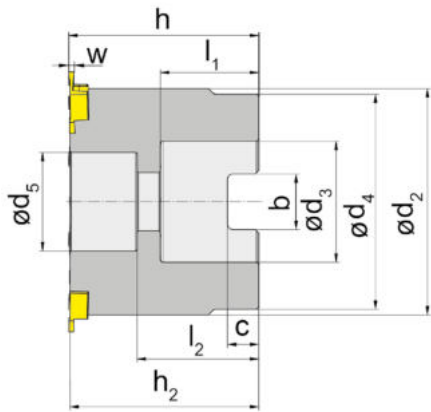
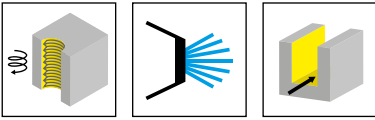
Messerkopf Milling cutter	Spannschraube Clamping Screw	TORX PLUS®-Schlüssel TORX PLUS® Wrench
M275...	3.5.10T10P	T10PL

Wendeschnidplatte Indexable insert

RS275

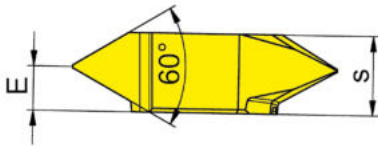
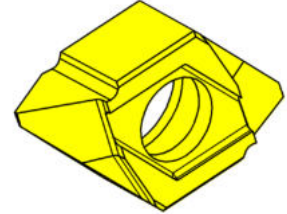
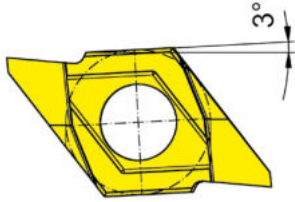

R = rechts wie gezeichnet
R = right hand version shown

HM-Sorten
Carbide grades
▲ ab Lager
on stock
Δ 4 Wochen
4 weeks

Bestellnummer Part number	P	P _{max}	E	s	Z	HIS	TA45
RS275.1535.01	1,5	3,5	2,3	4,1	2	275041R	▲
	P ●	M ●	K ●	N ●	S ●	H -	



Übersicht
Overview

Seite/Page
350

Schaftfräser
End Mill
380

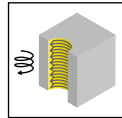

Seite/Page
351

Messerkopf
Milling cutter
380

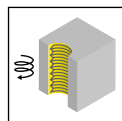

Seite/Page
352

Wendeschneidplatte
Indexable insert
314

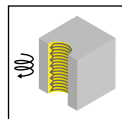

Seite/Page
353

G

Achtung:

Beim Nenndurchmesser handelt es sich immer um den größten \emptyset am Gewinde. In der Regel richtet sich die Bezeichnung nach der Größe des Gewindes.
Bsp: M12 x 1 -> Nenndurchmesser 12

Bei Unterschreitung des angegebenen Nenndurchmessers wird durch den Nachschnitt des Werkzeugs kein lehrenhaltiges Gewinde mehr erreicht.

Attention:

The nominal diameter is always the largest \emptyset on the thread. As a rule, the designation is based on the size of the thread.
Example: M12 x 1 -> nominal diameter 12

Recutting of the milling tool will create profile errors if the nominal diameter of the component will be smaller than recommended.

380



G

**Gewindefräser
(zirkular)**

ab Schneidkreis \varnothing 44 mm

**Thread Milling Cutter
(by circular interpolation)**

from cutting edge \varnothing 44 mm

Teilprofil, metrisch Typ 314

Partial profile, metric type 314

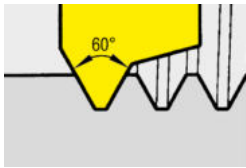

Steigung/Pitch P	1,5	2,0	2,5	3,0	4,0	5,0	5,5	6,0
Nenndurchmesser / Nominal diameter								
Typ / type 314 / Ds 44								
R314.1535.01	≥ 52	≥ 50	≥ 50	≥ 50				
R314.2140.01					≥ 72			
R314.3260.01								≥ 85
R314.4060.01					≥ 65		≥ 56	≥ 64
Typ / type 314 / Ds 63								
R314.1535.01	≥ 72	≥ 70	≥ 70	≥ 70				
R314.2140.01					≥ 95			
R314.3260.01								≥ 110
R314.4060.01					≥ 88			≥ 80





Abbildung = rechtsschneidend
Picture = right hand cutting version

Bestellnummer Part number	Z	Ds	d	l ₁	d ₁	λ	Form	HWS
380.0044.03A	3	44	25	125	34	14°	A	314027R • 314041R • 314052R
380.0044.03B	3	44	25	125	34	14°	B	314027R • 314041R • 314052R
380.0044.03E	3	44	25	125	34	14°	E	314027R • 314041R • 314052R

Ersatzteile

Spare Parts

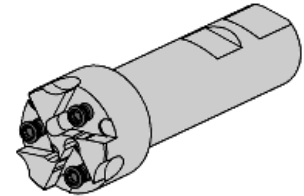
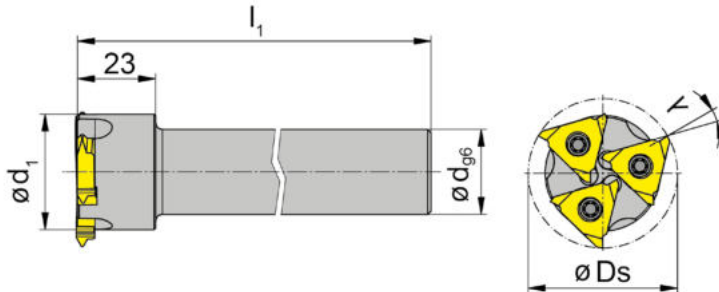
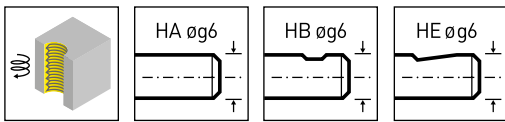
Schaftfräser End Mill	Spannschraube Clamping Screw	TORX PLUS®-Schlüssel TORX PLUS® Wrench
380...	5.12T20P	T20PQ





Abbildung = rechtsschneidend
Picture = right hand cutting version

Bestellnummer Part number	Z	Ds	h ₂	h	d ₃	l ₁	l ₂	λ	d ₂	HWS
380.0063.05	5	63	39,6	40	22	20	27,6	10°	51	314027R • 314041R • 314052R

Aufnahmebohrung und Mitnahme nach DIN 138
Cutterhole and cross keyway as per DIN 138

G

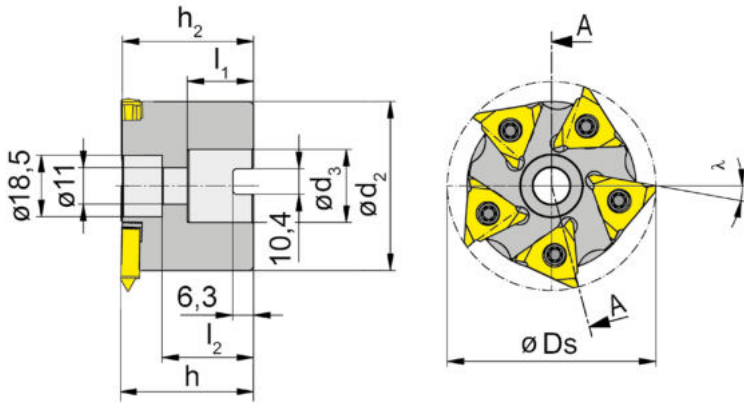
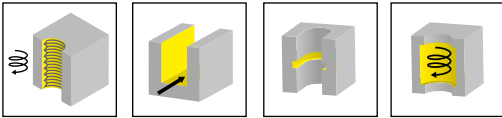
Ersatzteile
Spare Parts

Messerkopf Milling cutter	Spannschraube Clamping Screw	TORX PLUS®-Schlüssel TORX PLUS® Wrench
380.0063.05	5.12T20P	T20PQ



Abbildung = rechtsschneidend
Picture = right hand cutting version

HM-Sorten
Carbide grades
▲ ab Lager
on stock
Δ 4 Wochen
4 weeks

Bestellnummer Part number	P	P _{max}	E	s	Ds	Z	HIS	TN35
R314.1535.01	1,5	3,5	3,3	5,45	44	3	314052R	▲
R314.2140.01	4	4	3	5,45	44	3	314052R	▲
R314.4060.01	4	6	2,7	5,45	44	3	314052R	▲
R314.3260.01	6	6	2,7	5,45	63	3	314052R	▲

P	●
M	●
K	●
N	●
S	●
H	-

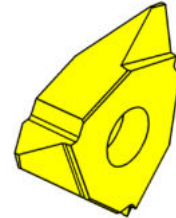
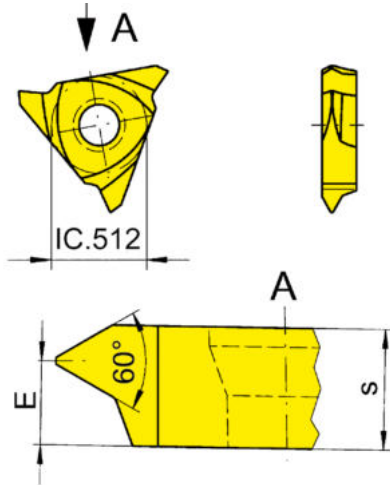
Hinweis:

R314.3260.01 ausschließlich für Messerkopf 380.0063.05

Note:

R314.3260.01 only for milling cutter 380.0063.05



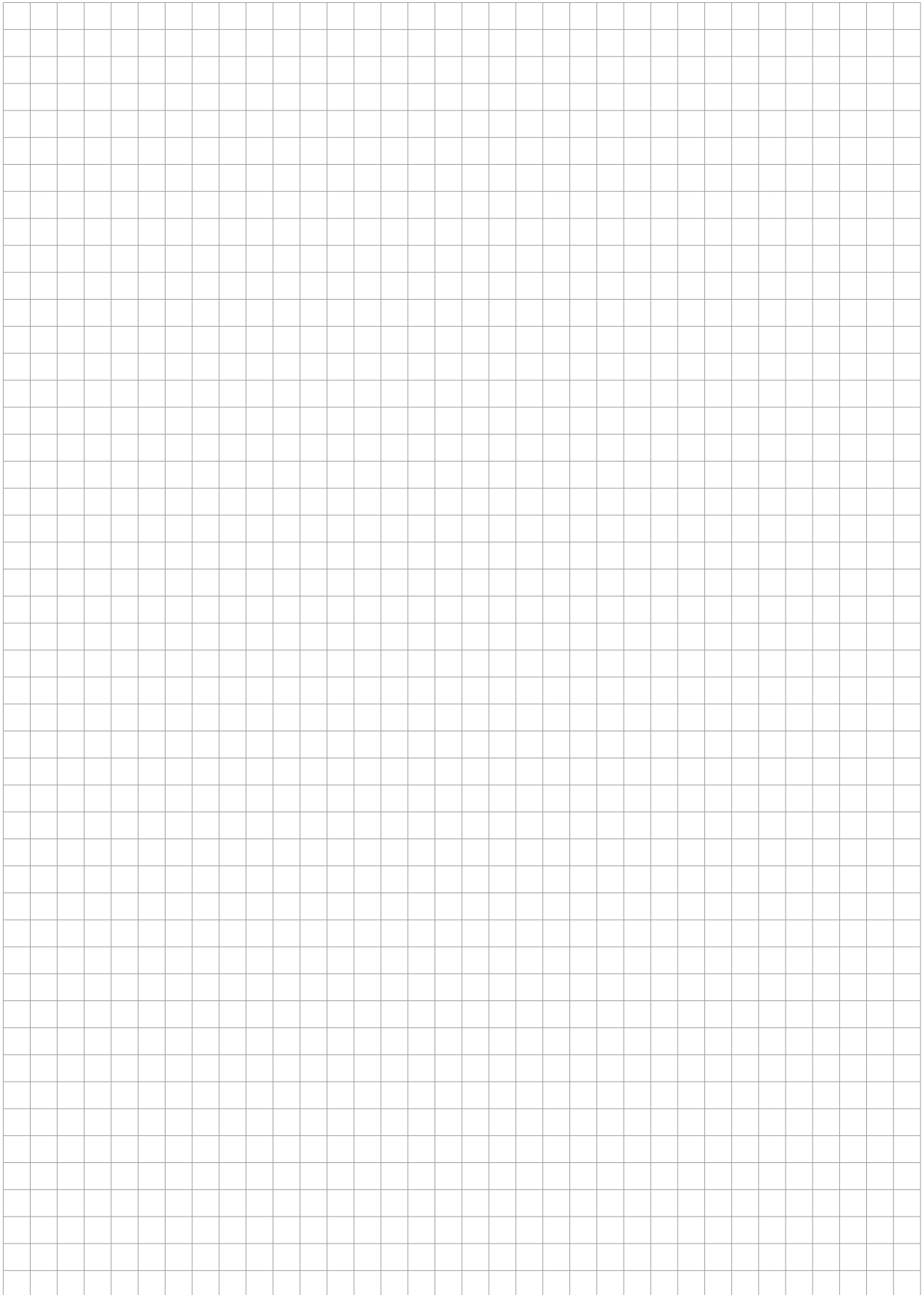

G

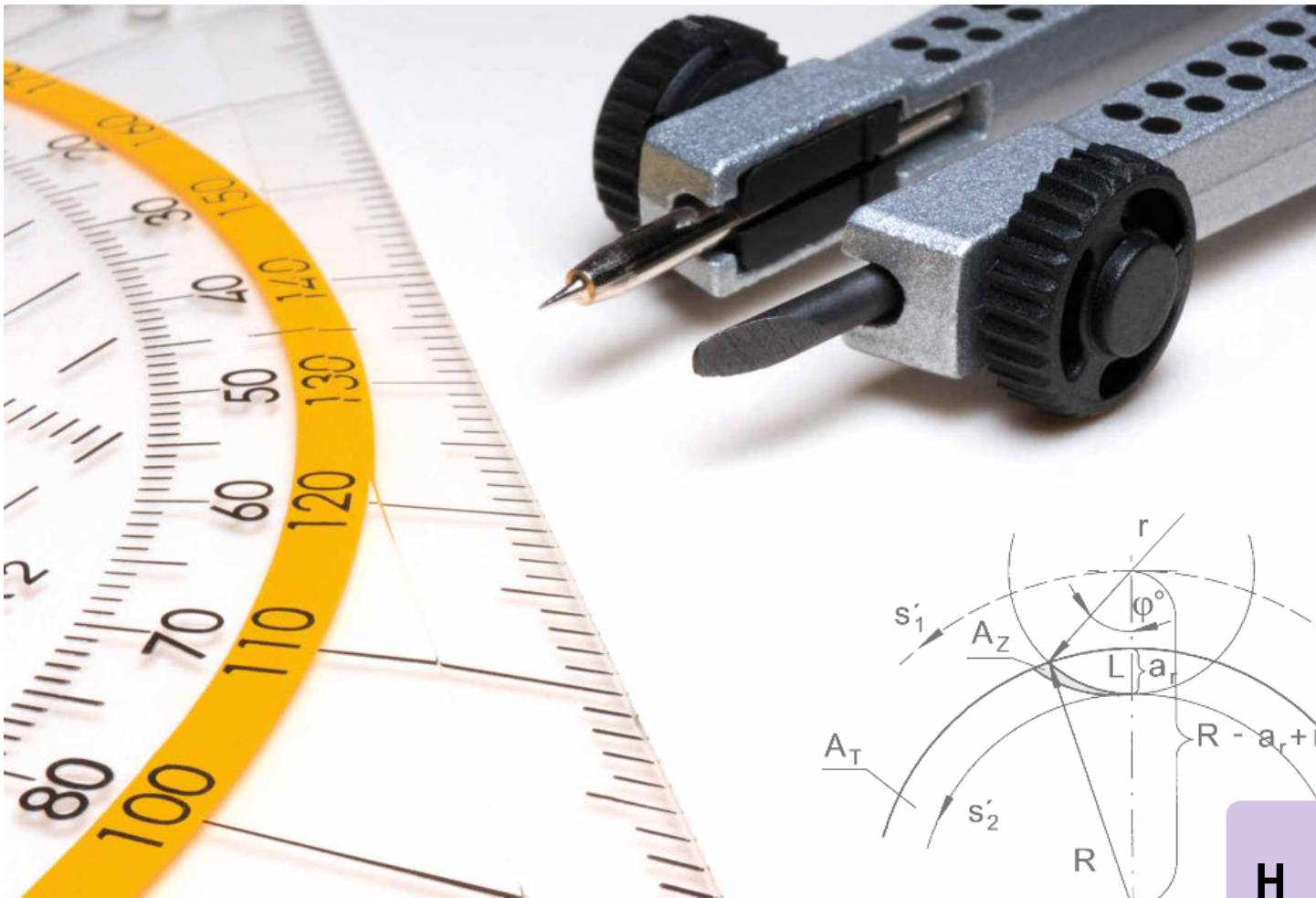

H

Inhalt/Summary	Seite/Page
Ermittlung des Vorschubs Calculating the Feed Rate	356
Formelzeichen Symbols	357
Formeln Formulas	358 - 359
Schnittdaten Cutting Data	360 - 365

Mittlere Spandicke h_m zur Ermittlung des Vorschubs

Medium chip thickness h_m for calculating the feed rate

ISO	108,111,116, 306-336, 606-636,911-939	S310 / 314 / S275 / S475	S101
	h_m (mm)	h_m (mm)	h_m (mm)
P	0,01 - 0,05	0,01 - 0,05	0,01 - 0,04
M	0,01 - 0,04	0,01 - 0,04	0,01 - 0,03
K	0,01 - 0,05	0,01 - 0,05	0,01 - 0,03
N	0,01 - 0,05	0,01 - 0,05	0,01 - 0,06
S	0,01 - 0,04	0,01 - 0,04	0,01 - 0,02

H

$$f_z = (h_m \times \pi \times d_e \times \phi_s) / (360^\circ \times a_e) \text{ [vereinfacht } f_z = h_m \times \sqrt{d_e/a_e} \text{ bei } a_e/d_e < 0,3]$$

$$f_z = (h_m \times \pi \times d_e \times \phi_s) / (360^\circ \times a_e) \text{ [simplified } f_z = h_m \times \sqrt{d_e/a_e} \text{ with } a_e/d_e < 0,3]$$

ISO

a_r	a_e	radiale Schnitttiefe radial depth of cut
d	d_e	Schneidkreis-Ø [mm] Cutting edge Ø [mm]
f		Vorschub pro Umdrehung $f = f_z \cdot Z$ [mm/U] [mm/rev] Feed per revolutions
f_z	s_z	Vorschub/Zahn $f_z = \frac{v_f}{Z \cdot n}$ [mm] Feed/tooth
h_m		mittlere Spandicke medium thickness of chip
n		Drehzahl $n = \frac{v_c \cdot 1000}{d \cdot \pi}$ [1/min] Revolutions
r		Radius Fräser Radius of cutter
R		Radius Werkstück Radius of workpiece
v_c		Schnittgeschwindigkeit $v_c = \frac{d \cdot \pi \cdot n}{1000}$ [m/min] Cutting speed
v_f	s'	Vorschubgeschwindigkeit $v_f = f_z \cdot Z \cdot n$ [mm/min] Feed rate
v_{f2}	s'_2	Vorschubgeschwindigkeit der Schneide (Nutgrund-Ø) Feed rate of tool tip
v_{f3}	s'_1	Vorschubgeschwindigkeit der Fräsmittelpunktsbahn Feed rate of tool centre
Z		Zähnezahl Number of teeth
ϕ_s		Eingriffswinkel Angle of action

Innennutfräsen

Milling of an internal groove

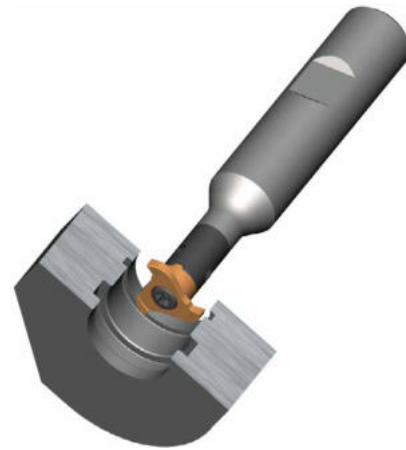
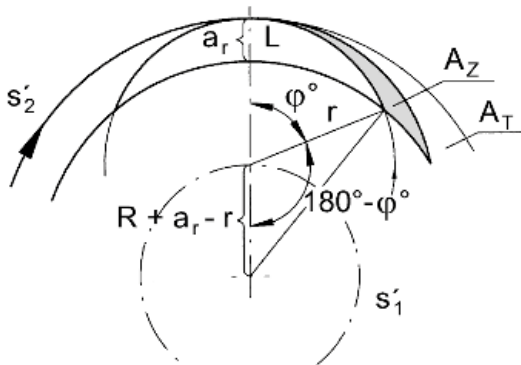

$$\cos [180^\circ - \varphi^\circ] = \frac{r^2 + [R + a_r - r]^2 - R^2}{2r [R + a_r - r]} \longrightarrow 180^\circ - \varphi^\circ \longrightarrow \varphi^\circ$$

Eingriffslänge $L = \frac{\pi \cdot 2r \cdot \varphi^\circ}{360^\circ}$ mm
Length of cut

Spandicke $A_z = L \cdot h_m$ mm²
Area of chip

Insgesamt zu zerspanende Fläche $A_T = \pi [(R + a_r)^2 - R^2]$ mm²
Area of groove section

Gesamt-Zerspanzeit (für AT) $t = \frac{A_T}{n \cdot z \cdot A_z}$ min
Time for cut (for AT)

Vorschubgeschwindigkeit der Fräsmittelpunktsbahn $s'_1 = \frac{\pi \cdot 2 (R - r + a_r)}{t}$ mm/min
Feed rate of tool centre

Vorschubgeschwindigkeit der Schneide (Nutgrund-Ø) $s'_2 = s'_1 \frac{R + a_r}{R - r + a_r}$ mm/min
Feed rate of tool tip

Fräsen gerader Nuten - außen

Milling of a linear groove - external

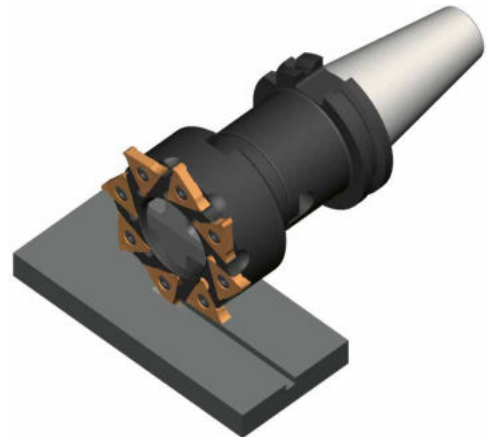
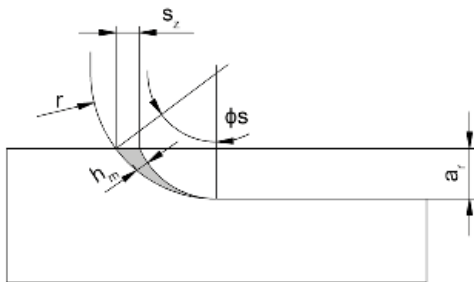

$$s_z = h_m \sqrt{\frac{2r}{a_r}}$$

$$s = n \cdot z \cdot s_z \text{ mm/min}$$

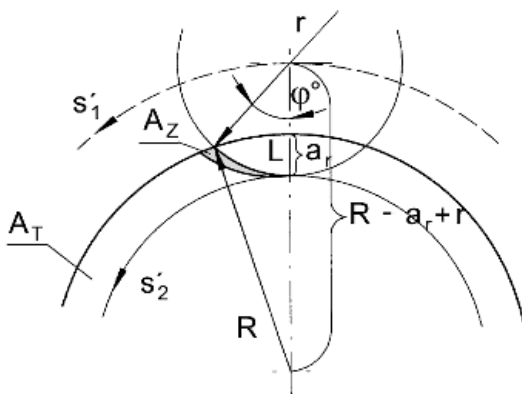

$$\cos \varphi^\circ = \frac{r^2 + [R + r - a_r]^2 - R^2}{2r [R + r - a_r]} \rightarrow \varphi^\circ$$

Eingriffslänge $L = \frac{\pi \cdot 2r \cdot \varphi^\circ}{360^\circ}$ mm
Length of cut

Spandicke $A_z = L \cdot h_m$ mm²
Area of chip

Insgesamt zu zerspanende Fläche $A_T = \pi [(R + a_r)^2 - R^2]$ mm²
Area of groove section

Gesamt-Zerspanzeit (für AT) $t = \frac{A_T}{n \cdot z \cdot A_z}$ min
Time for cut (for AT)

Vorschubgeschwindigkeit der Fräsmittelpunktsbahn $s'_1 = \frac{\pi \cdot 2 (R - r + a_r)}{t}$ mm/min
Feed rate of tool centre

Vorschubgeschwindigkeit der Schneide (Nutgrund-Ø) $s'_2 = s'_1 \frac{R + a_r}{R - r + a_r}$ mm/min
Feed rate of tool tip

Schnittdaten Nut- und Zirkularfäsen

Cutting Data Groove and Circular Milling



Werkstoff Material		Materialgruppe Material group	Härte (HB) Hardness Brinell	Zug- festigkeit R_m [N/mm ²] Tensile Strength	Beispiel Werkstoff Example Material	MG12	Tl2_ TN3_	
P	unlegierter Stahl Carbon steel	~ 0,2 % C	P1.1	125	430	CK15		300-160
		~ 0,4% C geglüht annealed	P1.2	190	610	19Mn6		250-170
		~ 0,4% C vergütet quenched	P1.3	210	640	36Mn5		230-170
		~ 0,6% C geglüht annealed	P1.4	190	610	C55		190-120
		~ 0,6% C vergütet quenched	P1.5	300	1000	CK60		170-120
		Automatenstahl Free cutting steel	P1.6	220	750	9SMn28		190-120
	niedrig legierter Stahl (<5%) Alloyed steel	gegüht annealed	P2.1	180	590	100Cr6		180-110
		vergütet quenched	P2.2	280	960	14NiCr10		160-100
		vergütet quenched	P2.3	350	1250	34CrMo4		130-70
		vergütet quenched	P2.4	430	1450	55Cr3		120-70
	hochlegierter Stahl (>5%) high alloyed steel	gegüht annealed	P3.1	200	680	X10CrAl18		140-80
		gehärtet hardened	P3.2	350	1200	X210Cr2		
	Stahlguss Cast steel	unlegiert unalloyed	P4.1	180	590	GE200		220-160
		legiert alloyed	P4.2	220	750	GX40CrSi28		140-80
	Sinterstahl Sintered steel	weich soft	P5.1	220	570	Sint-D39		140-80
M	Rostfreier Stahl Stainless steel	martensitisch ferritisch martensitic ferritic	M1.1	200	680	X16Cr13		
		austenitisch austenitic ferritic	M1.2	300	1000	X6CrNiMo- Ti17-12-2		
		austenitisch ferritisch austenitic	M1.3	230	780	X2CrNiMo- N17-13-3		
H	Gehärtete Stähle Hardened steels	50-55 HRC	H1.1	-	-			
		55-60 HRC	H1.2	-	-			
		60-63 HRC	H1.3	-	-			
		> 63HRC	H1.4	-	-			

H

Schnittdaten Nut- und Zirkularfäsen

Cutting Data Groove and Circular Milling



Werkstoff Material		Materialgruppe Material group	Härte (HB) Hardness Brinell	Zug- festigkeit R_m [N/mm ²] Tensile Strength	Beispiel Werkstoff Example Material			
						MG12	Tl2_ TN3_	
K	Grauguss Grey cast iron	niedrige Festigkeit low tensile strength	K1.1	180	250	GG-25		150-90
		hohe Festigkeit high tensile strength	K1.2	250	350	GG-40		100-70
	Kugelgraphit- guss Spheroidal graphite cast iron	ferritisch ferritic	K2.1	160	400	GGG-40		130-90
		perlitisch perlitic	K2.1	260	700	GGG-60		100-50
	Temperguss Malleable cast iron	ferritisch ferritic	K3.1	200	400	GTW-45		120-60
		perlitisch perlitic	K3.2	260	700	GTS-55-04		140-80
	Ausferritisches Gusseisen / ADI Ausferritic spheroidal cast iron / ADI	vergütet quenched	K4.1	260	800			
		vergütet quenched	K4.2	350	1050			
		vergütet quenched	K4.3	450	1400			
N	Al-Legierungen Al-alloys	nicht vergütbar not heat treatable	N1.1	30		AlMg1	550-300	
		vergütbar heat treatable	N1.2	100	340	AlMgSi1	220-180	
	Al-Guss- Legierung Al-cast-alloy	< 6% Si	N2.1	80	300	AlMgSi6	220-180	
		6-10% Si	N2.2	100	320	AlSi7Mg	100-80	
		10-15 % Si	N2.3	130	450	AlSi12	120-100	
	Kupfer- Legierungen Copper-alloys	Reinkupfer Pure copper	N3.1	100	340	Cu	120-100	
		Messing, Bronze Brass	N3.2	90	310	CuZn40Pb		
		Messing bleifrei Lead-free brass	N3.3	110	430	CuZn40		
		hochfest high strength	N3.4	300	1000	CuZn25Al5- Mn4Fe3		
	Graphit Graphite		N4.1					
S	Warmfeste Legierung (Fe) Heat resistant alloy	geglüht annealed	S1.1	200	670			
		gehärtet hardened	S1.2	275	930			
	Warmfeste Legierung (Ni, Co) Heat resistant alloy	geglüht annealed	S2.1	250	840	Inconel 600		
		gehärtet hardened	S2.2	350	1200	Inconel 713		

H

Schnittdaten Nut- und Zirkularfäsen

Cutting Data Groove and Circular Milling



Werkstoff Material		Materialgruppe Material group	Härte (HB) Hardness Brinell	Zug- festigkeit R_m [N/mm ²] Tensile Strength	Beispiel Werkstoff Example Material	MG12	TI2_ TN3_	
S	Titan	Titanlegierung α Titanium alloy α	S3.1	120	240			
		Titanlegierung α - β Titanium alloy α - β	S3.2	360	1200			
		Titanlegierung β Titanium alloy β	S3.3	410	1400			
O	Thermoplaste Thermoplastics		01.1			150 - 50		
	Duroplaste Duro plaste		01.2			150 - 50		
	Kunststoffe glasfaser- verstärkt Plastics glass fibre reinforced	GFK	01.3			150 - 50		
	Kunststoffe kohlefaser- verstärkt Plastics carbon fibre reinforced	CKF	01.4			300 - 150		

H

Schnittdaten Nut- und Zirkularfäsen

Cutting Data Groove and Circular Milling



Schnittgeschwindigkeit v_c (m/min) / Startwerte
Cutting speed v_c (m/min) / Start values

AS4_ TH3_ TA4_ TF4_	AN2_ AN4_ RC2_ RC4_	EG5_	IG3_	SG3_	DD2_				
				100-70					
				80-50					
				70-40					



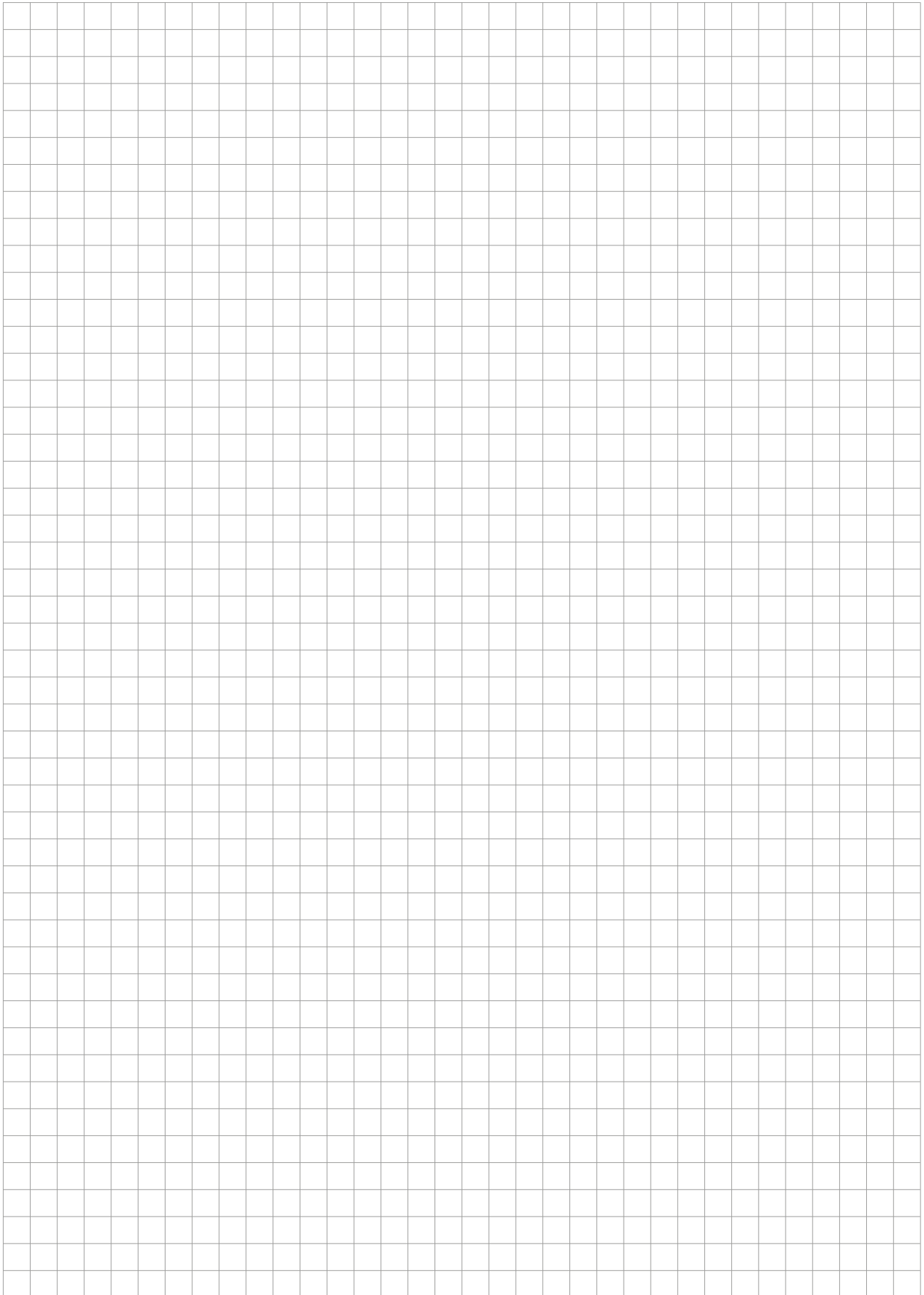

H





System	Seite/Page
Verzahnungsfräsen / Gear Milling	371
Verzahnungsstoßen / Gear Broaching	383
Wälzschälen / Gear Skiving	387
Entgraten / Deburing	393
Abwälzstoßen / Gear Shaping	395
Schlagzahnfräsen / Single-Point Gear Milling	397
Kegelradfräsen / Bevel Gear Milling	399
5-Achs-Fräsen / 5-Axis Milling of Gear Teeth	403



Übersicht Verzahnungsverfahren

Overview Gear Processes

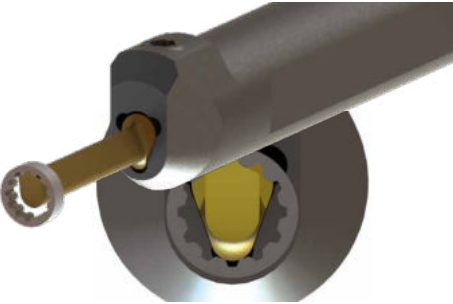





Technologie Technology	Kleinserie Small series	Mittlere Losgrößen Medium batch sizes	Großserie Large series
Verzahnungsfräsen (außen) Gear milling (external) 	+++	++	-
Verzahnungsstoßen (außen und innen) Gear broaching (external and internal) 	+++	++	+
Wälzschälen (außen und innen) Gear skiving (external and internal) 	-	+	+++
Abwälzstoßen (außen) Gear shaping (external) 	-	+	+++

Übersicht Verzahnungsverfahren

Overview Gear Processes



Technologie Technology	Kleinserie Small series	Mittlere Losgrößen Medium batch sizes	Großserie Large series
Schlagzahnfräsen (außen) Single-point gear milling (external) 	-	+++	+
Kegelradfräsen (außen) Bevel gear milling (external) 	+	+	+++
5-Achsfräsen von Verzahnungen (außen) 5-Axis milling of gears (external) 	+++	-	-
Entgraten von Verzahnungen Deburring of gears 	+++	+++	+++



Fräsplatten für Stirnräder und Zahnwellen

Milling inserts for spur gears and gear shafts



Stirnräder, Zahnstangen Bezugsprofil 1 nach DIN 3972 Cylindrical gears, Tooth bars Basic profile 1 according to DIN 3972	Zahnwellen, Welle-Nabe, Kerbverzahnung DIN 5480/ANSI B92.1 Gear shafts, Shaft-hub, Serration DIN 5480/ANSI B92.1	Schneidplatte Insert Typ type	Ds [mm]
$mn \leq 0,8$	$mn \leq 1 / dB \geq 40$	606	11,7
$mn \leq 1$	$mn \leq 1,5 / dB \geq 40$	608	15,7
$mn \leq 1,25$	$mn \leq 2 / dB \geq 40$	611	17,7
$mn \leq 1,5$	$mn \leq 3 / dB \geq 22$	613	21,7
$mn \leq 2$	$mn \leq 2,5 / dB \geq 40$	628	27,7
$mn \leq 2,5 / \text{Nr. 5 - 8}$	$mn \leq 2,5 / dB \geq 30$	632	31,7
$mn \leq 2,25 / \text{Nr. 2 - 8}$	$mn \leq 2,5 / dB \geq 30$	632	31,7
$mn \leq 2 \text{ Nr. 1 - 8}$	$mn \leq 2,5 / dB \geq 30$	632	31,7
$mn \leq 3$	$mn \leq 3 / dB \geq 50$	635	34,7
$mn \leq 1,5$	$mn \leq 2 / dB \geq 60$	636	35,7



VERZÄHNUNGSFRÄSEN

Modulgrößen von 0,5 bis 4 mm

GEAR MILLING

Module sizes from 0.5 up to 4 mm



Bestellbeispiel

Ordering Example



Fräser-Nr. Milling cutter N°	*z (Zähnezahl Stirnrad) *z (N° of teeth cylindrical gear)
1	12 - 13
2	14 - 16
3	17 - 20
4	21 - 25
5	26 - 34
6	35 - 54
7	55 - 134
8	≥ 135...Zahnstange/Tooth bar



613.3972.100.8

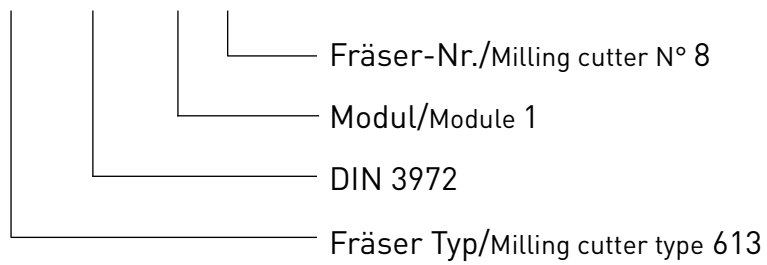

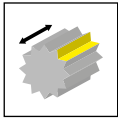

z6

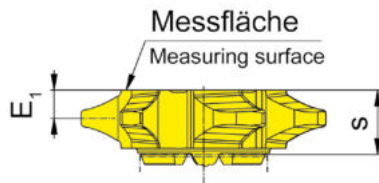
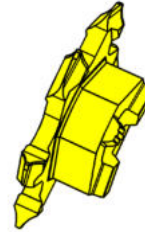
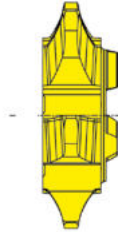
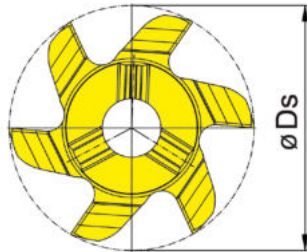

HM-Sorten
Carbide grades

▲ ab Lager
on stock

Δ 4 Wochen
4 weeks

Bestellnummer Part number	Modul Module	z_{min}	z_{max}	E_1	s	t_{max}	D_s	HIS	AS45
613.3972.050.1	0,5	12	13	1,1	5,7	1,1	21,7	313113R	Δ
613.3972.050.2	0,5	14	16	1,1	5,7	1,1	21,7	313113R	Δ
613.3972.050.3	0,5	17	20	1,1	5,7	1,1	21,7	313113R	▲
613.3972.050.4	0,5	21	25	1,1	5,7	1,1	21,7	313113R	Δ
613.3972.050.5	0,5	26	34	1,1	5,7	1,1	21,7	313113R	▲
613.3972.050.6	0,5	35	55	1,1	5,7	1,1	21,7	313113R	Δ
613.3972.050.7	0,5	55	134	1,1	5,7	1,1	21,7	313113R	Δ
613.3972.050.8	0,5	135	999	1,1	5,7	1,1	21,7	313113R	Δ
613.3972.070.1	0,7	12	13	1,6	5,3	1,5	21,7	313113R	Δ
613.3972.070.2	0,7	14	16	1,6	5,3	1,5	21,7	313113R	Δ
613.3972.070.3	0,7	17	20	1,6	5,3	1,5	21,7	313113R	Δ
613.3972.070.4	0,7	21	25	1,6	5,3	1,5	21,7	313113R	Δ
613.3972.070.5	0,7	26	34	1,6	5,3	1,6	21,7	313113R	Δ
613.3972.070.6	0,7	35	55	1,6	5,3	1,6	21,7	313113R	Δ
613.3972.070.7	0,7	55	134	1,6	5,3	1,6	21,7	313113R	Δ
613.3972.070.8	0,7	135	999	1,6	5,3	1,6	21,7	313113R	Δ

Eingriffswinkel 20°
Pressure angle 20°

Zahnformfräser für Stirnräder mit Evolventenverzahnung nach DIN 867 Bezugsprofil 1 nach DIN 3972 für Fertigbearbeitung, Profilverschiebungsfaktor 0
Gear milling cutter for cylindrical gears with involuted flanks according to DIN 867 Basic profile 1 according to DIN 3972 for finishing, addendum shift 0

P	●
M	●
K	●
N	○
S	●
H	-

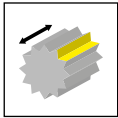

z6

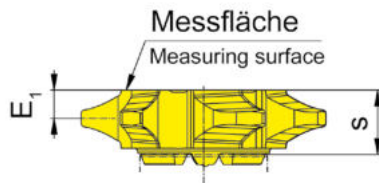
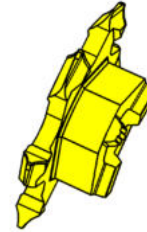
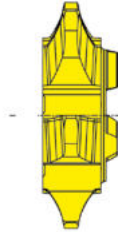
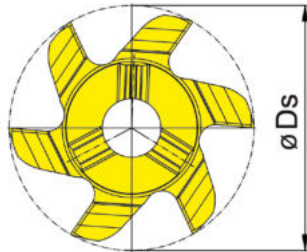

HM-Sorten
Carbide grades

▲ ab Lager
on stock

△ 4 Wochen
4 weeks

Bestellnummer Part number	Modul Module	z_{min}	z_{max}	E_1	s	t_{max}	D_s	HIS	AS45
613.3972.080.1	0,8	12	13	1,6	5,3	1,8	21,7	313113R	▲
613.3972.080.2	0,8	14	16	1,6	5,3	1,8	21,7	313113R	▲
613.3972.080.3	0,8	17	20	1,6	5,3	1,8	21,7	313113R	▲
613.3972.080.4	0,8	21	25	1,6	5,3	1,8	21,7	313113R	▲
613.3972.080.5	0,8	26	34	1,6	5,3	1,8	21,7	313113R	▲
613.3972.080.6	0,8	35	55	1,6	5,3	1,8	21,7	313113R	▲
613.3972.080.7	0,8	55	134	1,6	5,3	1,8	21,7	313113R	▲
613.3972.080.8	0,8	135	999	1,6	5,3	1,8	21,7	313113R	▲
613.3972.090.1	0,9	12	13	2,5	5,7	2,1	21,7	313113R	△
613.3972.090.2	0,9	14	16	2,5	5,7	2,1	21,7	313113R	△
613.3972.090.3	0,9	17	20	2,5	5,7	2,1	21,7	313113R	△
613.3972.090.4	0,9	21	25	2,5	5,7	2,1	21,7	313113R	△
613.3972.090.5	0,9	26	34	2,5	5,7	2,1	21,7	313113R	△
613.3972.090.6	0,9	35	55	2,5	5,7	2,1	21,7	313113R	△
613.3972.090.7	0,9	55	134	2,5	5,7	2,1	21,7	313113R	△
613.3972.090.8	0,9	135	999	2,5	5,7	2,1	21,7	313113R	△

Eingriffswinkel 20°
Pressure angle 20°

Zahnformfräser für Stirnräder mit Evolventenverzahnung nach DIN 867 Bezugsprofil 1 nach DIN 3972 für Fertigbearbeitung, Profilverschiebungsfaktor 0
Gear milling cutter for cylindrical gears with involuted flanks according to DIN 867 Basic profile 1 according to DIN 3972 for finishing, addendum shift 0

P	●
M	●
K	●
N	o
S	●
H	-

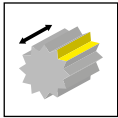

z6

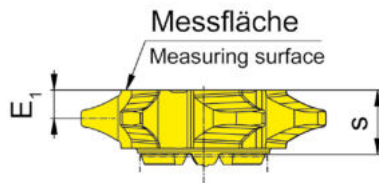
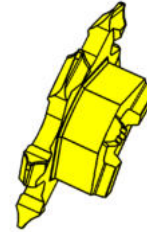
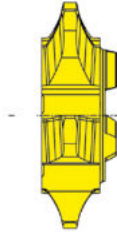
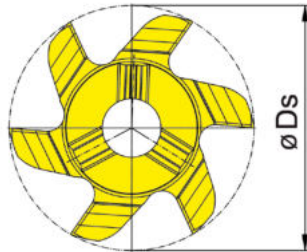

HM-Sorten
Carbide grades

▲ ab Lager
on stock

△ 4 Wochen
4 weeks

Bestellnummer Part number	Modul Module	z_{min}	z_{max}	E_1	s	t_{max}	D_s	HIS	AS45
613.3972.100.1	1	12	13	2,5	5,7	2,2	21,7	313113R	▲
613.3972.100.2	1	14	16	2,5	5,7	2,2	21,7	313113R	▲
613.3972.100.3	1	17	20	2,5	5,7	2,2	21,7	313113R	▲
613.3972.100.4	1	21	25	2,5	5,7	2,2	21,7	313113R	▲
613.3972.100.5	1	26	34	2,5	5,7	2,2	21,7	313113R	▲
613.3972.100.6	1	35	54	2,5	5,7	2,3	21,7	313113R	▲
613.3972.100.7	1	55	134	2,5	5,7	2,3	21,7	313113R	▲
613.3972.100.8	1	135	999	2,5	5,7	2,4	21,7	313113R	△
613.3972.125.1	1,25	12	13	2,5	5,7	2,6	21,7	313113R	△
613.3972.125.2	1,25	14	16	2,5	5,7	2,7	21,7	313113R	△
613.3972.125.3	1,25	17	20	2,5	5,7	2,7	21,7	313113R	△
613.3972.125.4	1,25	21	25	2,5	5,7	2,7	21,7	313113R	△
613.3972.125.5	1,25	26	34	2,5	5,7	2,7	21,7	313113R	△
613.3972.125.6	1,25	35	54	2,5	5,7	2,7	21,7	313113R	△
613.3972.125.7	1,25	55	134	2,5	5,7	2,8	21,7	313113R	△
613.3972.125.8	1,25	135	999	2,5	5,7	2,8	21,7	313113R	△

Eingriffswinkel 20°
Pressure angle 20°

Zahnformfräser für Stirnräder mit Evolventenverzahnung nach DIN 867 Bezugsprofil 1 nach DIN 3972 für Fertigbearbeitung, Profilverschiebungsfaktor 0
Gear milling cutter for cylindrical gears with involuted flanks according to DIN 867 Basic profile 1 according to DIN 3972 for finishing, addendum shift 0

P	●
M	●
K	●
N	○
S	●
H	-

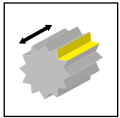

z6

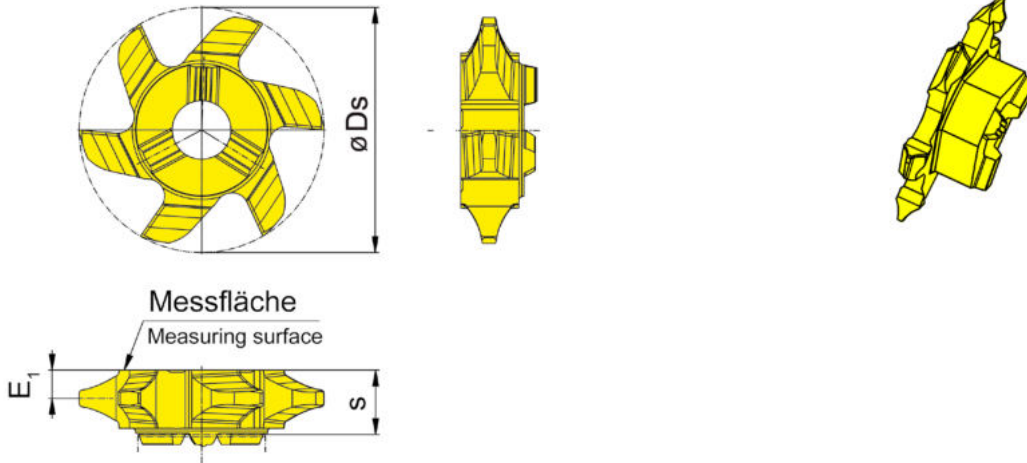

HM-Sorten
Carbide grades

▲ ab Lager
on stock

Δ 4 Wochen
4 weeks

Bestellnummer Part number	Modul Module	z_{min}	z_{max}	E_1	s	t_{max}	D_s	HIS	AS45
613.3972.150.1	1,5	12	13	2,5	5,7	3,1	21,7	313113R	Δ
613.3972.150.2	1,5	14	16	2,5	5,7	3,2	21,7	313113R	Δ
613.3972.150.3	1,5	17	20	2,5	5,7	3,2	21,7	313113R	▲
613.3972.150.4	1,5	21	25	2,5	5,7	3,3	21,7	313113R	Δ
613.3972.150.5	1,5	26	34	2,5	5,7	3,3	21,7	313113R	▲
613.3972.150.6	1,5	35	54	2,5	5,7	3,3	21,7	313113R	▲
613.3972.150.7	1,5	55	134	2,5	5,7	3,3	21,7	313113R	Δ
613.3972.150.8	1,5	135	999	2,5	5,7	3,3	21,7	313113R	▲

Eingriffswinkel 20°
Pressure angle 20°

Zahnformfräser für Stirnräder mit Evolventenverzahnung nach DIN 867 Bezugsprofil 1 nach DIN 3972 für Fertigbearbeitung, Profilverchiebungsfaktor 0
Gear milling cutter for cylindrical gears with involuted flanks according to DIN 867 Basic profile 1 according to DIN 3972 for finishing, addendum shift 0

P	●
M	●
K	●
N	o
S	●
H	-

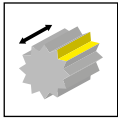

z6

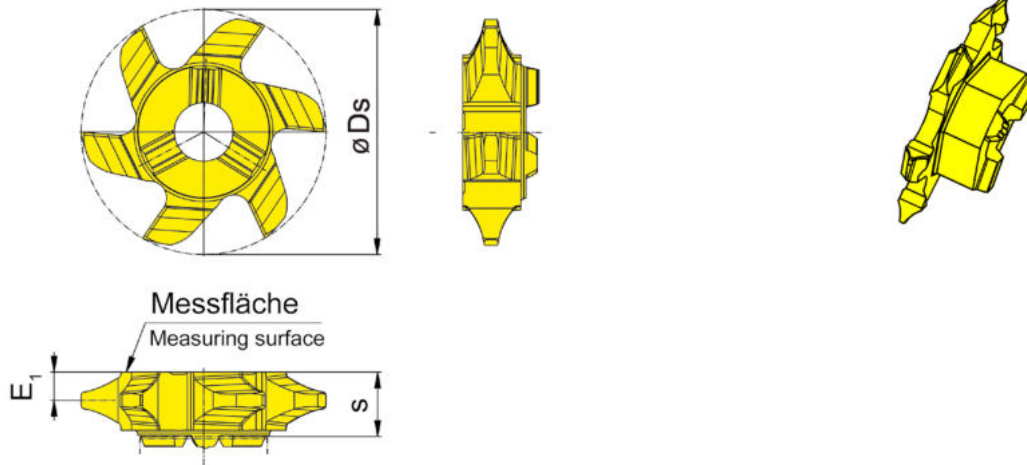

HM-Sorten
Carbide grades

▲ ab Lager
on stock

△ 4 Wochen
4 weeks

Bestellnummer Part number	Modul Module	z_{min}	z_{max}	E_1	s	t_{max}	D_s	HIS	AS/45
628.3972.175.1	1,75	12	13	3,4	7,45	3,8	27,7	328143R	△
628.3972.175.2	1,75	14	16	3,4	7,45	3,8	27,7	328143R	△
628.3972.175.3	1,75	17	20	3,4	7,45	3,8	27,7	328143R	△
628.3972.175.4	1,75	21	25	3,4	7,45	3,9	27,7	328143R	△
628.3972.175.5	1,75	26	34	3,4	7,45	3,9	27,7	328143R	△
628.3972.175.6	1,75	35	54	3,4	7,45	3,9	27,7	328143R	△
628.3972.175.7	1,75	55	134	3,4	7,45	3,9	27,7	328143R	△
628.3972.175.8	1,75	135	999	3,4	7,45	3,9	27,7	328143R	△
628.3972.200.1	2	12	13	3,4	7,45	4,2	27,7	328143R	△
628.3972.200.2	2	14	16	3,4	7,45	4,2	27,7	328143R	▲
628.3972.200.3	2	17	20	3,4	7,45	4,2	27,7	328143R	△
628.3972.200.4	2	21	25	3,4	7,45	4,3	27,7	328143R	▲
628.3972.200.5	2	26	34	3,4	7,45	4,4	27,7	328143R	▲
628.3972.200.6	2	35	54	3,4	7,45	4,4	27,7	328143R	△
628.3972.200.7	2	55	134	3,4	7,45	4,4	27,7	328143R	▲
628.3972.200.8	2	135	999	3,4	7,45	4,5	27,7	328143R	△

Eingriffswinkel 20°
Pressure angle 20°

Zahnformfräser für Stirnräder mit Evolventenverzahnung nach DIN 867 Bezugsprofil 1 nach DIN 3972 für Fertigbearbeitung, Profilverschiebungsfaktor 0
Gear milling cutter for cylindrical gears with involuted flanks according to DIN 867 Basic profile 1 according to DIN 3972 for finishing, addendum shift 0

P	●
M	●
K	●
N	○
S	●
H	-

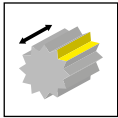

z6

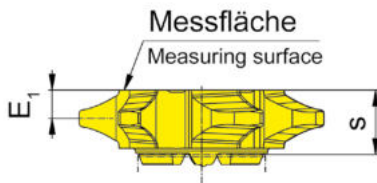
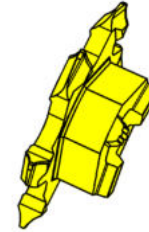
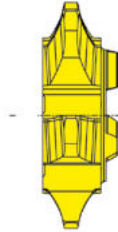
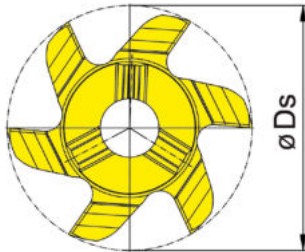

HM-Sorten
Carbide grades

▲ ab Lager
on stock

Δ 4 Wochen
4 weeks

Bestellnummer Part number	Modul Module	z_{min}	z_{max}	E_1	s	t_{max}	D_s	HIS	AS45
632.3972.225.2	2,25	14	16	3,45	7,5	4,7	31,7	332143R	Δ
632.3972.225.3	2,25	17	20	3,45	7,5	4,8	31,7	332143R	Δ
632.3972.225.4	2,25	21	25	3,45	7,5	4,9	31,7	332143R	Δ
632.3972.225.5	2,25	26	34	3,45	7,5	4,9	31,7	332143R	Δ
632.3972.225.6	2,25	35	54	3,45	7,5	5	31,7	332143R	Δ
632.3972.225.7	2,25	55	134	3,45	7,5	5	31,7	332143R	Δ
632.3972.225.8	2,25	135	999	3,45	7,5	5	31,7	332143R	Δ

Eingriffswinkel 20°
Pressure angle 20°

Zahnformfräser für Stirnräder mit Evolventenverzahnung nach DIN 867 Bezugsprofil 1 nach DIN 3972 für Fertigbearbeitung, Profilverschiebungsfaktor 0

Gear milling cutter for cylindrical gears with involuted flanks according to DIN 867 Basic profile 1 according to DIN 3972 for finishing, addendum shift 0

P	●
M	●
K	●
N	○
S	●
H	-

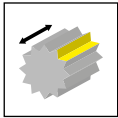

z6

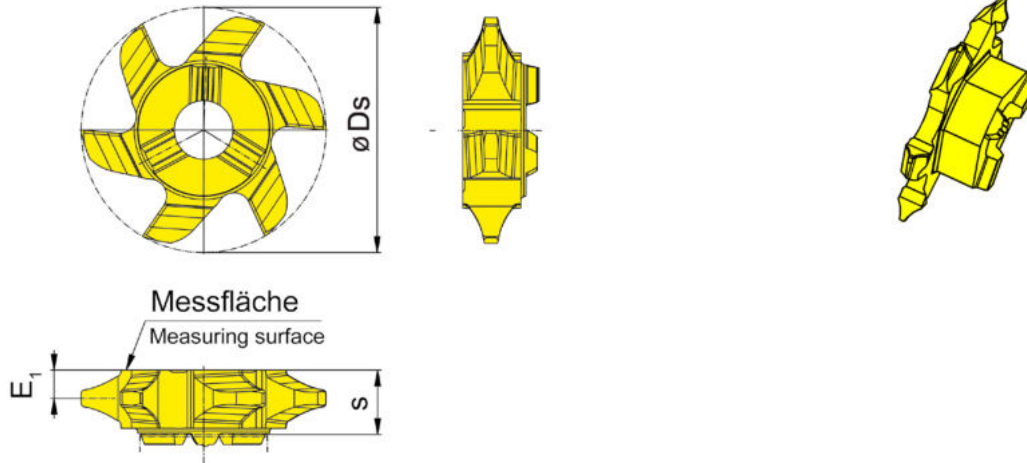

HM-Sorten
Carbide grades

▲ ab Lager
on stock

Δ 4 Wochen
4 weeks

Bestellnummer Part number	Modul Module	z_{min}	z_{max}	E_1	s	t_{max}	D_s	HIS	AS45
635.3972.225.1	2,25	12	13	5,5	11,9	4,7	34,7	335175R	Δ
635.3972.250.1	2,5	12	13	5,5	11,9	5,4	34,7	335175R	Δ
635.3972.250.2	2,5	14	16	5,5	11,9	5,4	34,7	335175R	Δ
635.3972.250.3	2,5	17	20	5,5	11,9	5,4	34,7	335175R	Δ
635.3972.250.4	2,5	21	25	5,5	11,9	5,5	34,7	335175R	Δ
635.3972.250.5	2,5	26	34	5,5	11,9	5,5	34,7	335175R	Δ
635.3972.250.6	2,5	35	54	5,5	11,9	5,5	34,7	335175R	Δ
635.3972.250.7	2,5	55	134	5,5	11,9	5,7	34,7	335175R	Δ
635.3972.250.8	2,5	135	999	5,5	11,9	5,7	34,7	335175R	Δ
635.3972.275.1	2,75	12	13	5,5	11,9	5,7	34,7	335175R	Δ
635.3972.275.2	2,75	14	16	5,5	11,9	5,8	34,7	335175R	Δ
635.3972.275.3	2,75	17	20	5,5	11,9	5,8	34,7	335175R	Δ
635.3972.275.4	2,75	21	25	5,5	11,9	5,9	34,7	335175R	Δ
635.3972.275.5	2,75	26	34	5,5	11,9	5,9	34,7	335175R	Δ
635.3972.275.6	2,75	35	54	5,5	11,9	6	34,7	335175R	Δ
635.3972.275.7	2,75	55	134	5,5	11,9	6,1	34,7	335175R	Δ
635.3972.275.8	2,75	135	999	5,5	11,9	6,1	34,7	335175R	Δ
635.3972.300.1	3	12	13	5,5	11,9	6,2	34,7	335175R	Δ
635.3972.300.2	3	14	16	5,5	11,9	6,4	34,7	335175R	Δ
635.3972.300.3	3	17	20	5,5	11,9	6,4	34,7	335175R	Δ
635.3972.300.4	3	21	25	5,5	11,9	6,4	34,7	335175R	Δ
635.3972.300.5	3	26	34	5,5	11,9	6,5	34,7	335175R	Δ
635.3972.300.6	3	35	54	5,5	11,9	6,5	34,7	335175R	Δ
635.3972.300.7	3	55	134	5,5	11,9	6,6	34,7	335175R	Δ
635.3972.300.8	3	135	999	5,5	11,9	6,6	34,7	335175R	Δ

Eingriffswinkel 20°
Pressure angle 20°

Zahnformfräser für Stirnräder mit Evolventenverzahnung nach DIN 867 Bezugsprofil 1 nach DIN 3972 für Fertigbearbeitung, Profilverschiebungsfaktor 0
Gear milling cutter for cylindrical gears with involuted flanks according to DIN 867 Basic profile 1 according to DIN 3972 for finishing, addendum shift 0

P	●
M	●
K	●
N	○
S	●
H	-



Abbildung = rechtsschneidend
Picture = right hand cutting version

Bestellnummer Part number	Z	Ds	h	d ₅	d ₂	d ₃	HWS
M279.0100.A32.10.10.IK	10	100	50	17,5	79	32	279105N
M279.0100.A32.2.10.05.IK	10	100	50	17,5	79	32	279105R • 279105L

Ersatzteile
Spare Parts

Aufsteckfräser Arbour Mounted Cutter	Spannschraube Clamping Screw	TORX PLUS®-Schlüssel TORX PLUS® Wrench
M279...	030.0516.T20P	T20PQ

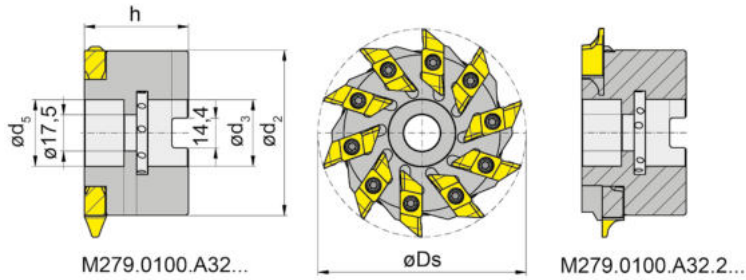
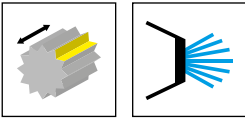
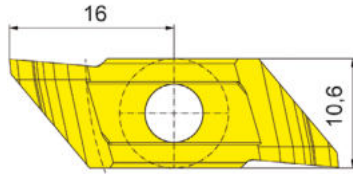
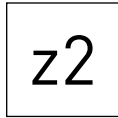
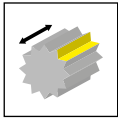

„A“ = einreihig
= single-row

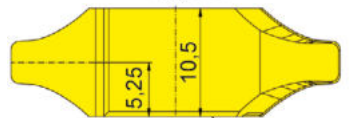

Anlageseite
Blockside



„B“ = zweireihig
= two-row

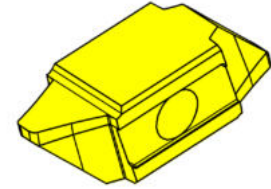

HM-Sorten
Carbide grades

▲ ab Lager
on stock

Δ 4 Wochen
4 weeks

Bestellnummer Part number	Modul Module	Z _{min}	Z _{max}	E ₁	s	t _{max}	Z	Form	HIS	AS45
RS279.3972.325.1	3,25	12	13	5,25	10,5	6,7	2	A	279105R	Δ
RS279.3972.325.2	3,25	14	16	5,25	10,5	6,8	2	A	279105R	Δ
RS279.3972.325.3	3,25	17	20	5,25	10,5	7	2	A	279105R	Δ
RS279.3972.325.4	3,25	21	25	5,25	10,5	7	2	A	279105R	Δ
RS279.3972.325.5	3,25	26	24	5,25	10,5	7,1	2	A	279105R	Δ
RS279.3972.325.6	3,25	35	54	5,25	10,5	7,2	2	A	279105R	Δ
RS279.3972.325.7	3,25	55	134	5,25	10,5	7,2	2	A	279105R	Δ
RS279.3972.325.8	3,25	135	999	5,25	10,5	7,2	2	A	279105R	Δ
RS279.3972.350.1L	3,5	12	13	5,25	10,5	7,35	2	B	279105L	Δ
RS279.3972.350.1R	3,5	12	13	5,25	10,5	7,35	2	B	279105R	Δ
RS279.3972.350.2L	3,5	14	16	5,25	10,5	7,45	2	B	279105L	Δ
RS279.3972.350.2R	3,5	14	16	5,25	10,5	7,45	2	B	279105R	Δ
RS279.3972.350.3	3,5	17	20	5,25	10,5	7,4	2	A	279105R	Δ
RS279.3972.350.4	3,5	21	25	5,25	10,5	7,5	2	A	279105R	Δ
RS279.3972.350.5	3,5	26	34	5,25	10,5	7,65	2	A	279105R	Δ
RS279.3972.350.6	3,5	35	54	5,25	10,5	7,7	2	A	279105R	Δ
RS279.3972.350.7	3,5	55	134	5,25	10,5	7,8	2	A	279105R	Δ
RS279.3972.350.8	3,5	135	999	5,25	10,5	7,8	2	A	279105R	Δ

Eingriffswinkel 20°
Pressure angle 20°

Zahnformfräser für Stirnräder mit Evolventenverzahnung nach DIN 867 Bezugsprofil 1 nach DIN 3972 für Fertigbearbeitung, Profilverchiebungsfaktor 0

Gear milling cutter for cylindrical gears with involuted flanks according to DIN 867 Basic profile 1 according to DIN 3972 for finishing, addendum shift 0

P	●
M	●
K	●
N	○
S	●
H	-

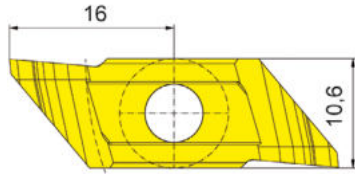
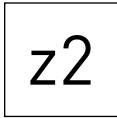
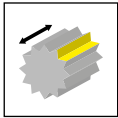

„A“ = einreihig
= single-row

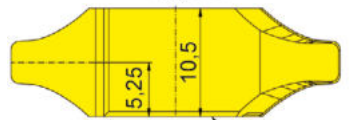

Anlageseite
Blockside



„B“ = zweireihig
= two-row

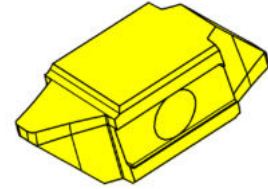

HM-Sorten
Carbide grades

▲ ab Lager
on stock

△ 4 Wochen
4 weeks

Bestellnummer Part number	Modul Module	Z _{min}	Z _{max}	E ₁	s	t _{max}	Z	Form	HIS	AS45
RS279.3972.375.1L	3,75	12	13	5,25	10,5	7,8	2	B	279105L	Δ
RS279.3972.375.1R	3,75	12	13	5,25	10,5	7,8	2	B	279105R	Δ
RS279.3972.375.2L	3,75	14	16	5,25	10,5	7,85	2	B	279105L	Δ
RS279.3972.375.2R	3,75	14	16	5,25	10,5	7,85	2	B	279105R	▲
RS279.3972.375.3L	3,75	17	20	5,25	10,5	8	2	B	279105L	Δ
RS279.3972.375.3R	3,75	17	20	5,25	10,5	8	2	B	279105R	Δ
RS279.3972.375.4L	3,75	21	25	5,25	10,5	8,1	2	B	279105L	▲
RS279.3972.375.4R	3,75	21	25	5,25	10,5	8,1	2	B	279105R	Δ
RS279.3972.375.5	3,75	26	34	5,25	10,5	8,1	2	A	279105R	Δ
RS279.3972.375.6	3,75	35	54	5,25	10,5	8,2	2	A	279105R	Δ
RS279.3972.375.7	3,75	55	134	5,25	10,5	8,3	2	A	279105R	Δ
RS279.3972.375.8	3,75	135	999	5,25	10,5	8,35	2	A	279105R	Δ
RS279.3972.400.1L	4	12	13	5,25	10,5	8,3	2	B	279105L	Δ
RS279.3972.400.1R	4	2	13	5,25	10,5	8,3	2	B	279105R	Δ
RS279.3972.400.2L	4	14	16	5,25	10,5	8,4	2	B	279105R	Δ
RS279.3972.400.2R	4	14	16	5,25	10,5	8,4	2	B	279105R	Δ
RS279.3972.400.3L	4	17	20	5,25	10,5	8,55	2	B	279105L	Δ
RS279.3972.400.3R	4	17	20	5,25	10,5	8,55	2	B	279105R	Δ
RS279.3972.400.4L	4	21	25	5,25	10,5	8,65	2	B	279105L	Δ
RS279.3972.400.4R	4	21	25	5,25	10,5	8,65	2	B	279105R	Δ
RS279.3972.400.5L	4	26	34	5,25	10,5	8,75	2	B	279105R	Δ
RS279.3972.400.5R	4	26	34	5,25	10,5	8,75	2	B	279105R	Δ
RS279.3972.400.6L	4	35	54	5,25	10,5	8,8	2	B	279105L	Δ
RS279.3972.400.6R	4	35	54	5,25	10,5	8,8	2	B	279105R	Δ
RS279.3972.400.7	4	55	134	5,25	10,5	8,8	2	A	279105R	Δ
RS279.3972.400.8	4	135	999	5,25	10,5	8,9	2	A	279105R	Δ

Eingriffswinkel 20°
Pressure angle 20°

Zahnformfräser für Stirnräder mit Evolventenverzahnung nach DIN 867 Bezugsprofil 1 nach DIN 3972 für Fertigbearbeitung, Profilverchiebungsfaktor 0
Gear milling cutter for cylindrical gears with involuted flanks according to DIN 867 Basic profile 1 according to DIN 3972 for finishing, addendum shift 0

P	●
M	●
K	●
N	○
S	●
H	-



VERZÄHNUNGSSTOSSEN

Bis Modul 5

GEAR BROACHING

Up to module 5

Verzahnungsstoßen

Gear Broaching



Beispiel: Supermini

Example:



Schneidplatte

Insert

N105

N110

S117

Typ Type	max. Modulgröße m_n ma. Module size m_n	min. Kopfkreis bei Hohlrad min. tip circle for ring gear	max. Flankenlänge max. length of flank
N105	1,5	4	20
N110	1,5	5	40
S117	5	14	-

Vorteile:

- Sonderwerkzeuge, abgestimmt auf Ihren Anwendungsfall
- Hohe Produktivität in Kombination mit Nutstoßgeräten
- Fertigbearbeitung auf einer Maschine
- Bis Modul 5 mm
- Kurze Lieferzeiten

Advantages:

- Special tools designed for your application
- High productivity in combination with broaching devices
- Finishing on one machine
- Up to module 5 mm
- Short delivery times

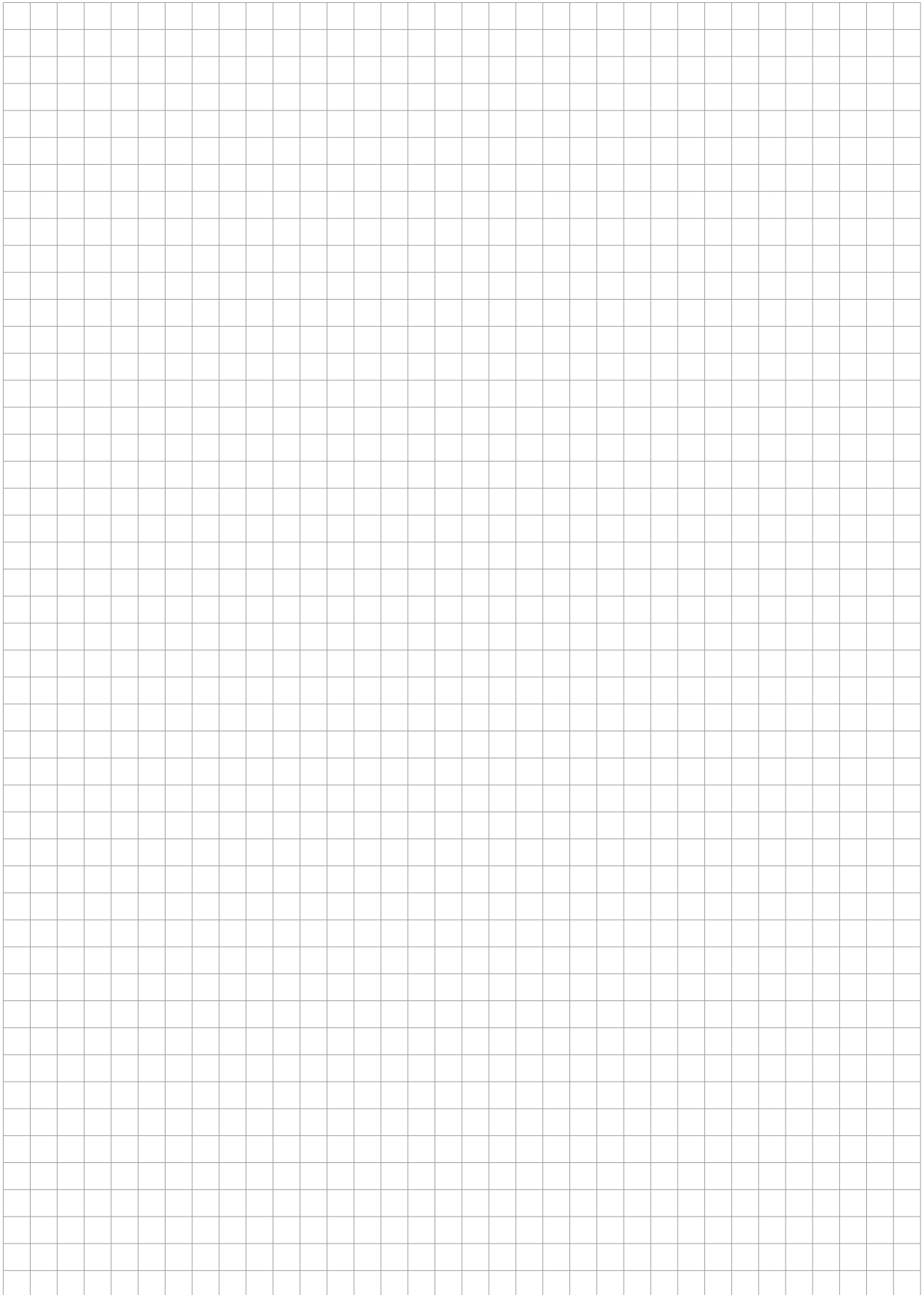



WÄLZSCHÄLEN

Verzahnungsbereich von Modul 0,2 mm bis Modul 8 mm

GEAR SKIVING

Gear teeth from module 0.2 mm up to module 8 mm

Produktgruppe WSA:

- Ab Modul $m = 0,2$ mm mit Treppenschliff
- Ab $d = 7$ mm
- Bis Modul $m = 1$ mm
- Bis $d = 30$ mm
- Vollhartmetallausführung
- Nachschärfbar
- Bei Bedarf Kopfschneidend (patentiert)

Product range WSA:

- From module $m_n = 0.2$ mm with step cut
- From $d = 7$ mm
- Up to module $m = 1$
- Up to $d = 30$ mm
- Solid carbide version
- Resharpenable
- Head cutting if required (patented)



Produktgruppe WSR:

- Präzisionsschnittstelle für höchste Rundlaufgenauigkeit (patentiert)
- Wechselplattensystem bis Modul $m_n = 4$ mm
- Ab $d = 25$ mm
- Unterschiedliche Kühlmittelzuführungen einstellbar
- Standardschäfte unterschiedlicher Länge ab Lager

Product range WSR:

- Precision interface for high concentricity (patented)
- Interchangeable insert systems up to module $m_n = 4$ mm
- From $d = 25$ mm
- Adjustable coolant supply
- Standard shanks of different lengths from stock



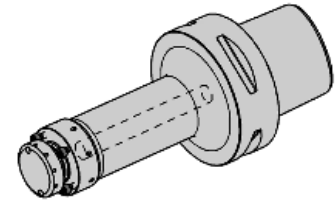
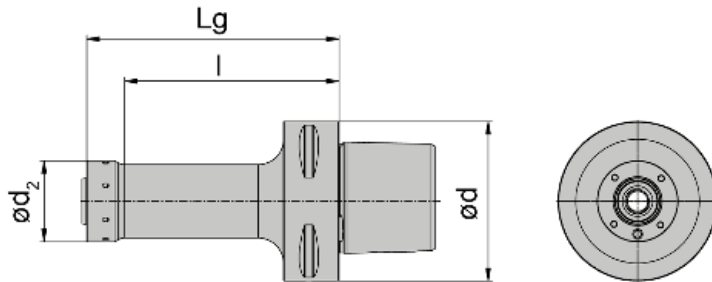
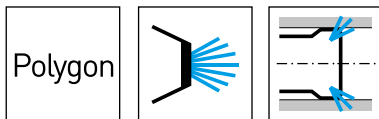

Bestellnummer Part number	l	Lg	d	d ₂	Kühlung Coolant	Größe Size
MDR.044.C6.060.W	45	60	63	32	D	04
MDR.044.C6.100.W	85	100	63	32	D	04
MDR.044.HSKT063.060.W	45	60	63	32	D	04
MDR.052.C6.060.W	45	60	63	39	D	05
MDR.052.C6.100.W	85	100	63	39	D	05
MDR.052.HSKT063.060.W	45	60	63	39	D	05
MDR.052.HSKT063.100.W	85	100	63	56	D	05
MDR.081.C6.060.W	45	60	63	56	D	08
MDR.081.C6.125.W	102	125	63	56	D	08
MDR.081.C8.060.W	45	60	80	56	D	08
MDR.081.C8.100.W	77	100	80	56	D	08
MDR.081.C8.125.W	102	125	80	56	D	08
MDR.081.HSKT063.060.W	45	60	63	56	D	08
MDR.081.HSKT063.100.W	77	100	63	56	D	08
MDR.081.HSKT063.125.W	102	125	63	56	D	08

Die Schäfte sind für das Wälzschälssystem WSR konzipiert und mit DR-Reibschneiden kompatibel. Standardmäßige Ausführung mit innerer Kühlmittelzufuhr „D“. Mittels Austausch des Kühlmittel-Verschlussstopfens durch den optional erhältlichen Kühlmittelverteiler, können die Schäfte auf Kühlmittelzufuhr Variante „A“ umgebaut werden.

The shanks are designed for the WSR Gear Skiving System and are compatible with DR reaming inserts. Standard version with internal coolant supply „D“. By replacing the coolant plug with the optionally available coolant distributor, the shanks can be converted to coolant supply version „A“.

Ersatzteile

Spare Parts

Wälzschälschaft Gear Skiving Holder	Schraube Screw	Torx-Schlüssel Torx Wrench
MDR....	C00 90 02	T8L
MDR.081...	C00 90 04	T15Q

Ausführung innere Kühlmittelzufuhr

Internal coolant supply design

Ausführung "D" - mit Dichtstopfen

Version "D" - with Sealing plug

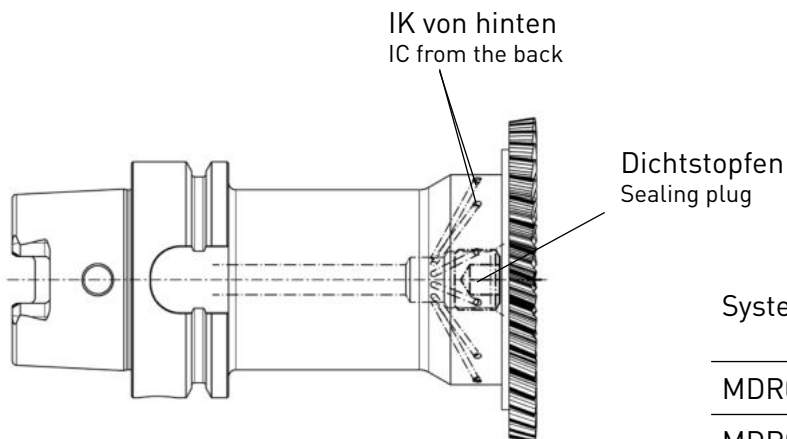

System	Dichtstopfen Sealing plug
MDR044	10.1.08.913
MDR052	12.1.12.913
MDR081	16.1.12.913

Ausführung "A" - mit IK-Verteiler

Version "A" - with Coolant distributor

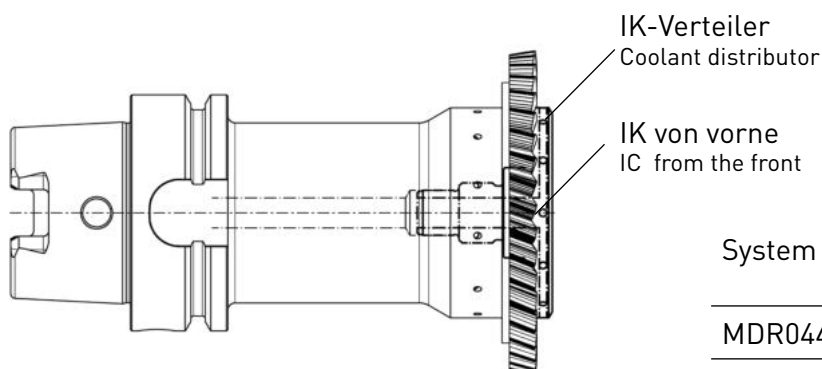

System	IK-Verteiler Coolant distributor
MDR044	020.2510.6506
MDR052	020.3212.6505
MDR081	020.5616.6246



Kühlmittelrohr Coolant tube	für System-Aufnahme for System Holder
020.4012.1306	HSK-A 40
020.5016.1307	HSK-A 50
020.6318.1308	HSK-A 63
020.0024.1310	HSK-A 100

Produktgruppe M117:

- Wechselplattensystem bis Modul 8
- Wechselplatte mit selbstzentrierendem Plattensitz
- Als Aufsteckversion für unterschiedliche Aufnahmen
- Mit integrierter Kühlmittelzuführung je nach Bearbeitungssituation

Product range M117:

- Interchangeable insert system up to module 8
- Interchangeable insert with self-centring insert seat
- Arbor version with different adapters
- With integrated coolant supply depending on the machining application





ENTGRATEN VON VERZÄHNUNGEN

DEBURRING OF GEARS

Das Anfasen von Stirnrädern erlaubt die Komplettbearbeitung auf einer Maschine mit exakten Geometrien. Gekoppelte Achsen von Werkstück und Werkzeug ermöglichen kurze Bearbeitungszeiten auch für Verzahnungen mit Schultern. Für jede Verzahnung wird das Werkzeug exakt ausgelegt und die Prozessdaten ermittelt.

The chamfering of spur gears allows complete machining on one machine with exact geometries. Synchronized rotation of workpiece and tool allow short machining times, even for gears with shoulders. The tool is designed exactly for each gear and the process data is determined.

Anwendungsbeispiel

Material: 1.7137 / 16MnCr5

Zähnezahl: 25

Modul: 1,25

Taktzeit: 8 s

Vc: 200 m/min

f: 150 mm/min

Machining example

Material: 1.7137 / 16MnCr5

Number of teeth: 25

Module: 1.25

Cycle time: 8 s

Cutting speed: 200 m/min

f: 150 mm/min

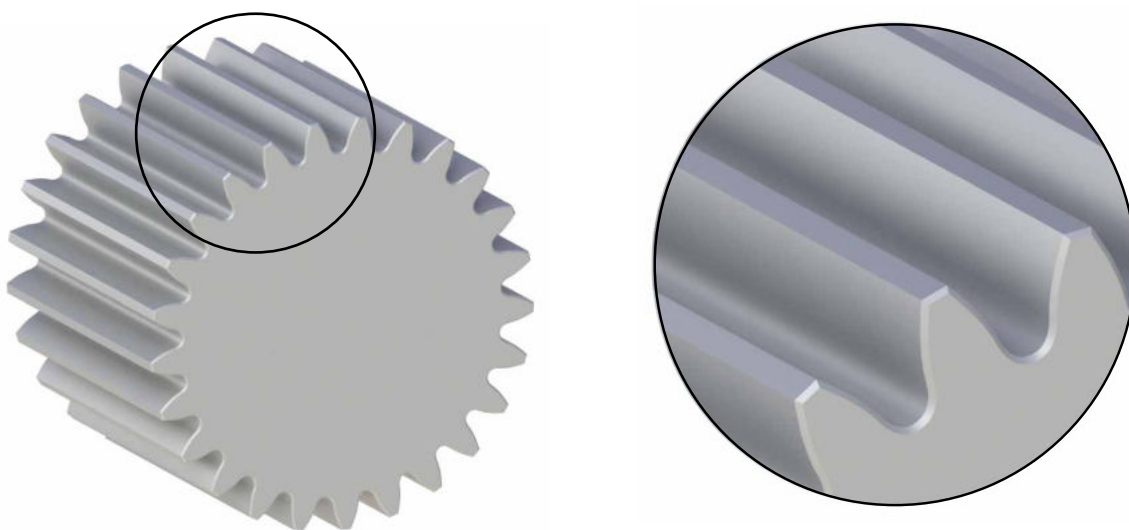



ABWÄLZSTOSSEN

Für Außen- und Innenverzahnungen

GEAR SHAPING

For external and internal gears

- Sonderwerkzeuge, abgestimmt auf Ihren Anwendungsfall
- Für Außen- und Innenverzahnungen
- Für Evolventen- und Passverzahnungen
- Für Sonderprofile
- Vom Modulgröße 0,2 mm bis 5 mm
- Werkzeug inklusive Prozessauslegung

- Special tools designed for your application
- For external and internal gears
- For involute and parallel splines
- For special profiles
- From module size 0.2 mm to 5 mm
- Tool incl. process design

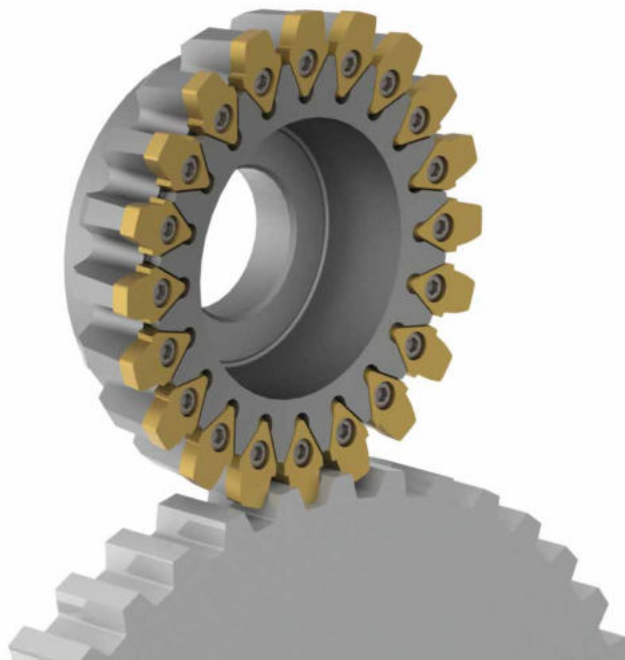



SCHLAGZAHNFRÄSEN

Verfahren mit reduzierten Werkzeugbewegungen

SINGLE-POINT GEAR MILLING

Process with fewer tool movements



Das Schlagzahnfräsen ist ein spanendes Fertigungsverfahren, bei dem das Werkstück und das Werkzeug in einem bestimmten Drehzahlverhältnis rotiert. Das Werkzeug wird hierbei in einem bestimmten Winkel gegenüber dem Werkstück angestellt. Wichtig ist, dass Werkstückspindel und Werkzeug gekoppelt zueinander laufen.

Mit dem Verfahren lassen sich neben Plan- und Stirnverzahnungen auch Evolventen oder Spline-Verzahnungen effizient herstellen. Hierzu lassen sich fast alle Frässysteme von HORN einsetzen.

Die Vorteile des Verfahrens sind reduzierte Werkzeugbewegungen, da alle Zahnücken in einem Durchgang hergestellt werden. Das Verfahren lässt sich auf so gut wie allen Drehfräszentren umsetzen und ist somit sehr universell einsetzbar.

Single-point gear milling is a machining process in which the workpiece and the tool rotate at a given speed ratio. The tool is set at a fixed angle to the workpiece. It is important that the spindle and tool run in synchrony with each other.

The process can be used to efficiently produce involute or spline gears in addition to crown and spur gears. Almost all HORN milling systems can be used for this purpose.

The advantages of the process are reduced tool movements as all tooth spaces are produced in one pass. The process can be implemented on almost all turn-mill centres and is therefore universally applicable.

Steckverzahnung

Material: 1.7137 / 16MnCr5

Zähnezahl: 36

Modul: 0,5

Takzeit: 15 s

Vc: 150 m/min

f_z : 0,1 mm / Z

Spline gearing

Material: 1.7137 / 16MnCr5

Number of teeth: 36

Module: 0.5

Cycle time: 15 s

Cutting speed: 150 m/min

f_z : 0,1 mm / Z

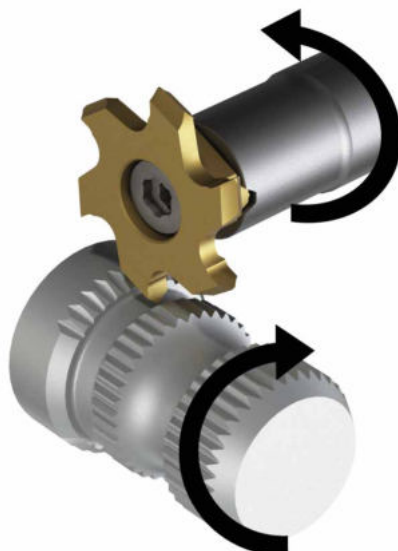



KEGELRADFRÄSEN

Von Modul 0,6 mm bis Modul 4 mm

BEVEL GEAR MILLING

From module 0.6 mm up to module 4 mm

Das Produktprogramm umfasst Werkzeuge zur Herstellung spiralförmiger Kegelräder mit epizykloidischer Zahn längsform und konstantem Zahnhöhenverlauf. Andere Verzahnungsformen bedürfen einer besonderen Prüfung.

Die Auslegung des Verzahnungsprozesses inklusive aller Bearbeitungsparameter erfolgt in Kooperation mit Index anhand des Kundenbauteils. Die Definition der Werkzeuggeometrie und Abstimmung der Werkzeugparameter ist abhängig vom Werkstückstoff und erfolgt mit dem Ziel hoher Werkstückgenauigkeiten und wirtschaftlicher Bearbeitungszeit.

Die Vor- und Rückseitenbearbeitung in einer Maschine ermöglicht die Komplettbearbeitung, dabei werden alle funktionsrelevanten Elemente in einer Aufspannung bearbeitet, mit dem Ziel höchster Präzision. Kegelräder von der Stange auf Universalmaschinen.

Produktprogramm:

Unser Produktprogramm umfasst Fräser für Systemschnittstellen in HSK-T40 und HSK-T63 in verschiedenen Flugkreisen und Zahnreihen/Gängigkeiten. Ein Fräsersatz kann für verschiedene Module und Kegelradabmessungen eingesetzt werden.

Zwei unterschiedliche Schneidplattengrößen decken Verzahnungsgrößen von Modul $m = 0,6$ mm bis Modul $m = 4$ mm ab.

The product range includes tools for the manufacture of spiral bevel gears with epicycloidal longitudinal tooth shape and constant tooth height. Other tooth forms require special testing.

The design of the gear cutting process including all machining parameters is carried out in cooperation with Index based on the customer's component. The definition of the tool geometry and coordination of the tool parameters depends on the workpiece material and is carried out with the aim of achieving high workpiece accuracy and economical machining time.

Front and rear machining in one set-up enables complete machining with all functionally relevant features are machined in one clamping with the aim of achieving maximum precision. Bevel gears from bar on universal machines.

Product range:

Our product range includes milling cutters with HSK-T40 and HSK-T63 interfaces in various flight circles and tooth rows/gear speeds. One set of cutters can be used for different modules and bevel gear dimensions.

Two different insert sizes cover gear tooth sizes from module $m = 0.6$ mm to module $m = 4$ mm.

Das Werkzeugprogramm wurde auf Index-Maschinen abgestimmt und beinhaltet folgenden Umfang:

- Fräskörper mit HSK-T40 oder HSK-T63 Schnittstelle
- Separater Messerkopf für Innen- und Außenschneider – 1-Flankenbearbeitung für höhere Präzision und Flexibilität bei Korrekturen
- Identische Grundkörper für die Innen- und Außenschneider
- Systemschneidplatten in 2 Größen für unterschiedliche Modulgrößen
- Systeme für Drehrichtung links oder rechts
- Adapterscheiben zur Anpassung der Werkzeuge an unterschiedliche Durchmesser/Flugkreisradien
- Flexible Korrektur der Zahn längsform durch Einstellen der Exzentrizität von Außen- und Innenradius durch verschiedene Distanzplatten
- Abgestimmte Substrate für unterschiedliche Werkstoffe

The tool program has been adapted to Index machines and includes the following:

- Milling body with HSK-T40 or HSK-T63 interface
- Separate cutter head for inside and outside cutters – 1 flank machining for higher precision and flexibility when making corrections
- Identical body for the internal and external cutters
- System inserts in 2 sizes for different module sizes
- Systems for clockwise or counter-clockwise rotation
- Adapter discs for adapting the tools to different diameters / flight circle radii
- Flexible correction of the longitudinal shape of the tooth by adjusting the eccentricity of the outer and inner radius using various spacer plates
- Coordinated substrates for different materials



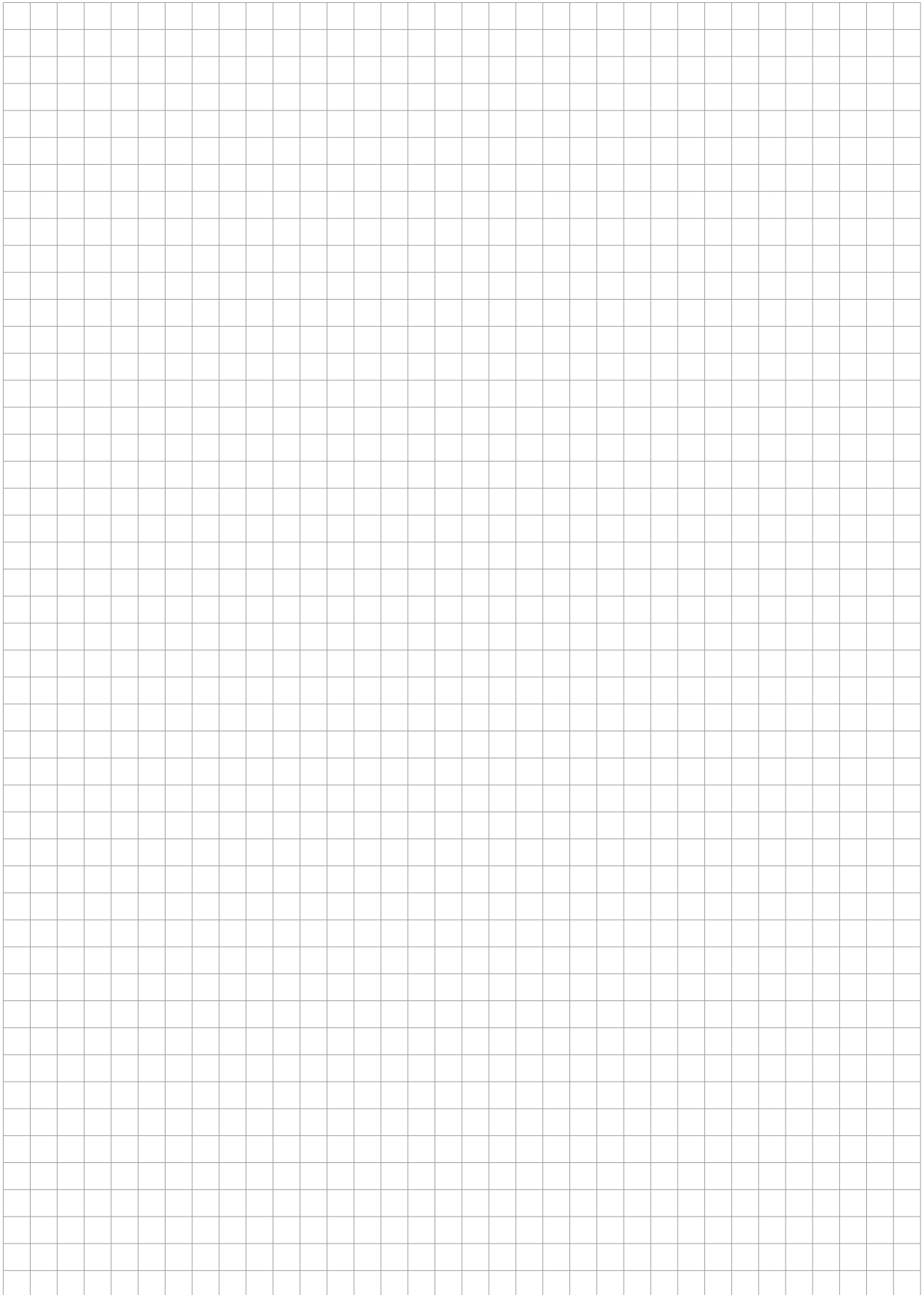



5-ACHS-FRÄSEN VON VERZÄHNUNGEN

5-AXIS MILLING OF GEAR TEETH



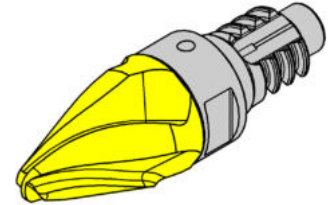
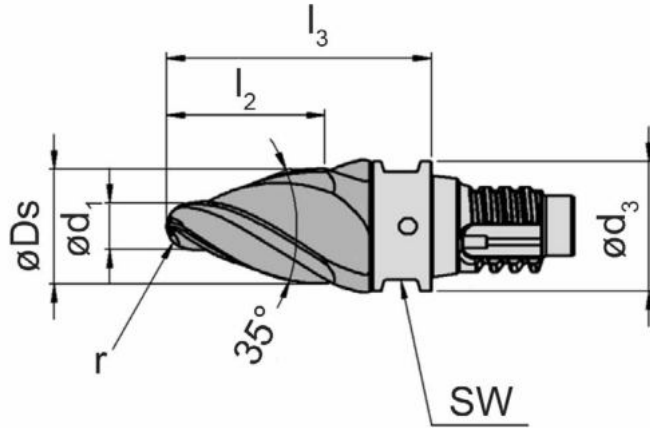
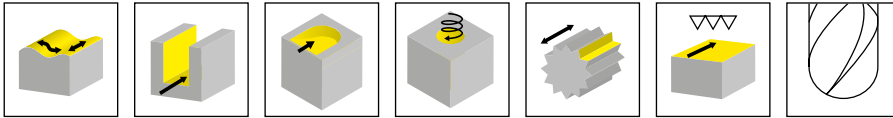

HM-Sorten
Carbide grades

▲ ab Lager
on stock

△ 4 Wochen
4 weeks

Bestellnummer Part number	System	SW	Z	Ds	d	r	l_3	d_1	a_p	HIS	AN2P
DGVZ.4.10.35.15.00	DG10	8	4	10	9,8	1,5	21	2,86	12,3	DG0101	▲
DGVZ.4.12.35.20.00	DG12	10	4	12	11,7	2	24	3,82	14,3	DG0121	▲
DGVZ.6.16.35.30.00	DG16	13	6	16	15,6	3	32	5,72	18,4	DG0161	▲
DGVZ.6.20.35.50.00	DG20	17	6	20	19,5	5	37	9,54	20,09	DG0201	▲

Hinweis:

Dieses Kapitel enthält lediglich die Schlichtwerkzeuge für Verzahnungen. Die Werkzeuge für die Schruppbearbeitung des Systems DAH finden Sie im Kapitel K, die Systeme DG und DS im Katalog VHM-FRÄSWERKZEUGE

Note:

This chapter contains only the finishing tools for gears. The tools for roughing System DAH can be found in chapter K, for systems DG and DS please see our catalogue SOLID CARBIDE MILLS

P	●
M	○
K	-
N	-
S	-
H	-

Modul 30 gerade verzahnt, bis Ø 4000 mm

Module 30 straight fluted, up to Ø 4000 mm

Schruppen Hochvorschubfräsen / Schlichten Abzeilen

Roughing high feed milling / Finishing copy milling

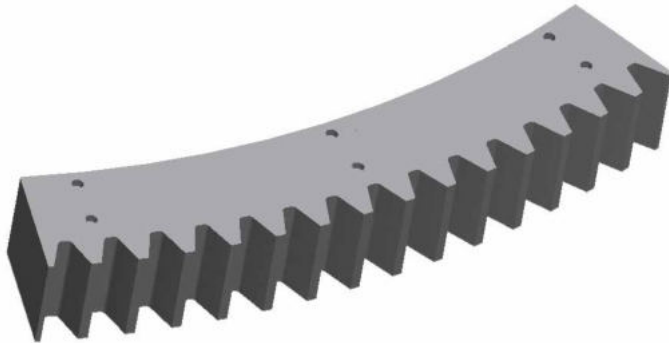

DAHM.37



DGH

Modul 13,56

Module 13,56

Schruppen Hochvorschubfräsen / Schlichten Abzeilen

Roughing high feed milling / Finishing copy milling



DGH



DSDS

Werkstoff Material	Werkzeuge Tools	Ds [mm]	v_c [m/min]	Bearbeitungszentrum Machining centre
C45	DGH	12/16	300	5-Achs 5-axis
C45	DSDS	8	200	5-Achs 5-axis
C45	DSK	10	190	5-Achs 5-axis
C45	DSM	12	260	5-Achs 5-axis

Axialmodul 7,9 / Ø 420 mm

Axial module 7,9 / Ø 420 mm

Schruppen konventionell / Schlichten Abzeilen

Roughing conventionally / Finishing copy milling



DPTP



DSK



DPTR

Werkstoff Material	Werkzeuge Tools	Ds [mm]	v_c [m/min]	Q [cm ³ /min]	Bearbeitungszentrum Machining centre
CuSn12Ni	DPTP	8	200	145	5-Achs 5-axis
CuSn12Ni	DSK	8	225	80	5-Achs 5-axis
CuSn12Ni	DPTR	6	225		5-Achs 5-axis

Bearbeitungstechnologie / Machining technology

<input type="checkbox"/> Wälzschälen Gear Skiving	<input type="checkbox"/> Verzahungsfräsen Gear milling	<input type="checkbox"/> Verzahnungsstoßen Gear broaching
--	---	--

Werkstückdaten / Workpiece data

Werkstückzeichnungsnr. Workpiece drawing no.		
Werkstoff Material		gehärtet hardened
Bezugsprofil bitte eintragen Basic rack		
Normalmodul / DP Normal module / diametral pitch		
Normaleingriffswinkel Normal pressure angle		
Zähnezahl Number of teeth		
Schrägungswinkel β (°) Helix angle		
Flankenrichtung Helix direction		
Kopfkreis- \emptyset Tip diameter	min	max
Fußkreis- \emptyset d_f (mm) Root diameter	min	max
Fußformkreis- \emptyset d_{Ff} (mm) Root form diameter oder/or Fußrundungsradius q_f (mm) Tooth root radius	min	max
	min	max
Radialbetrag Kopfkantenbruch h_k (mm) Height of semi topping		
Kopfformkreis- \emptyset d_{Fa} (mm) Tip form diameter		
Kopfrundungsradius q_{aPO} (mm) Tool tip radius		

Prüfmaß Verzahnung / Measuring type

Bitte wählen! Please choose!		
2-Kugelmaß M_{dK} (mm) Measurement between 2 balls	min	max
2-Rollenmaß M_{dr} Measurement between 2 rolls	min	max
Zahnweite über ___ Zähne Base tangent length	min	max
Zahndicke Tooth thickness	min	max
Zahnlückenweite Gap width	min	max
Messkörper- \emptyset (mm) Measuring body \emptyset		

Zusätzliche Zahnradparameter / Additional gear parameters

Vor- / Fertigbearbeitung (Aufmaß) Roughing / finishing (stock)		
Kopf- / Fußrücknahme / K-Profil Tip relief / root relief / K-chart	ja yes	nein no
Protuberanz Protuberance	ja yes	nein no
Höhenballigkeit / Längsballigkeit Profile crowning / length crowning	ja yes	nein no

Firma Company

Vertretung Distributor

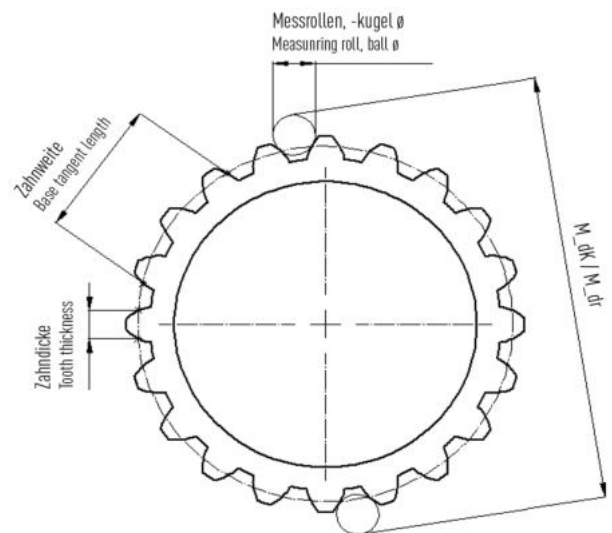
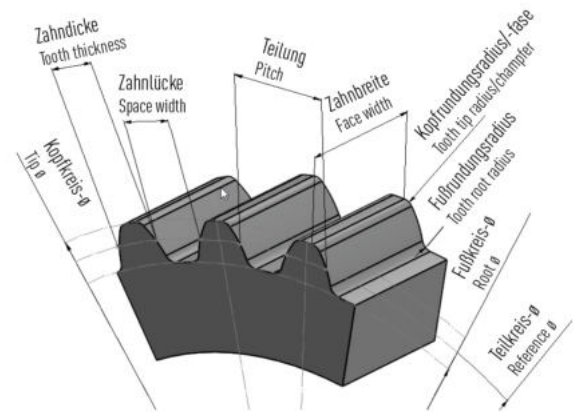

Maschinendaten / Machine data

Spindelaufnahme Spindle connection		
Schwenkwinkel Fräsachse Swivel angle of milling spindle	+	-
Maximale Drehzahl (synchronisiert) Maximum revolution (synchronized)		

Bemerkungen / Notes

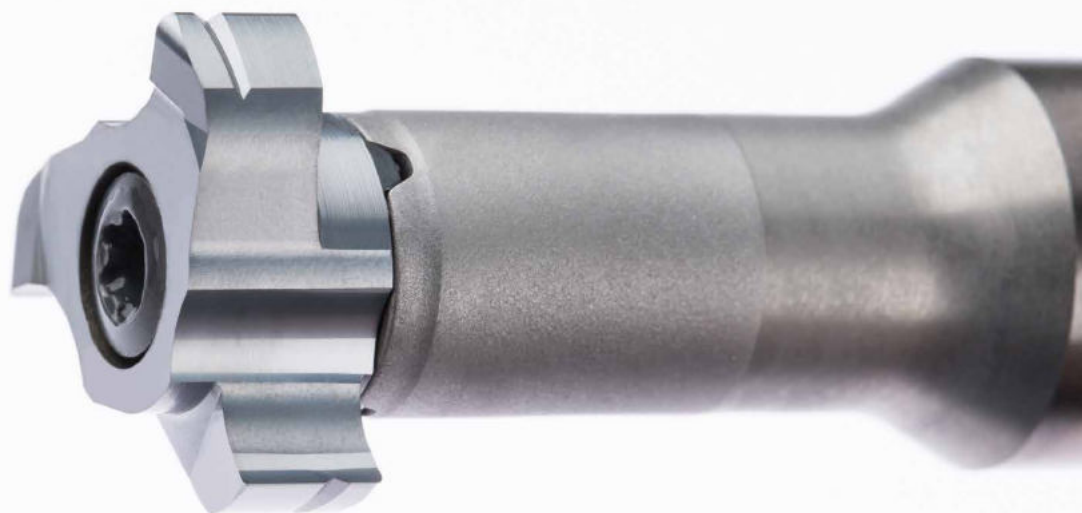

System/System	Seite/Page
M311	410
M313	416
M328	420
M406/M409	426

Fräserschaft
Milling shank
M311

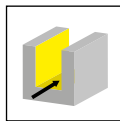

Seite/Page
412

Schneidplatte
Insert
311

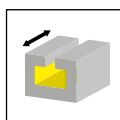

Seite/Page
413-414

M311



**T-Nuten-Fräser mit
wechselbarer
Schneidplatte**

ab SchneidkreisØ 17 mm

**T-Slot Cutter
with exchangeable
inserts**

from cutting edge Ø 17 mm

J



Abbildung = rechtsschneidend
Picture = right hand cutting version

Bestellnummer Part number	d	l ₁	l ₂	d ₁	Form	HWS
M311.0016.00A	16	90	25	9	A	311090R
M311.0016.00B	16	90	25	9	B	311090R
M311.0016.00E	16	90	25	9	E	311090R

Ds siehe Schneidplatten
Ds see inserts

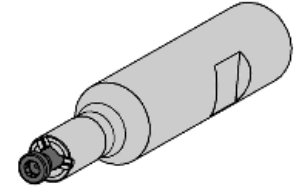
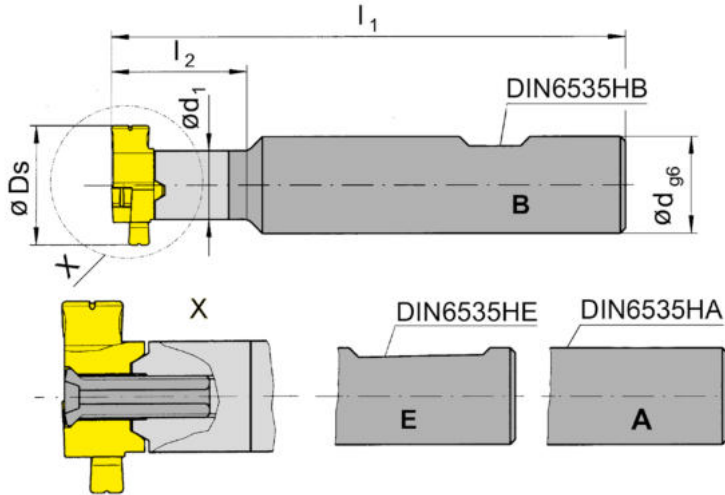
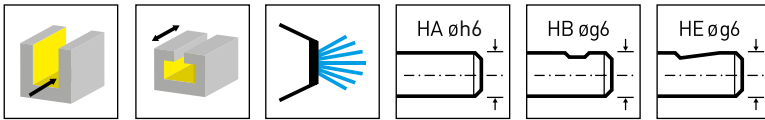

Ersatzteile
Spare Parts

Fräserschaft Milling shank	Spannschraube Clamping Screw	TORX PLUS®-Schlüssel TORX PLUS® Wrench
M311...	4.16T15KP	T15PQ

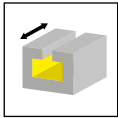

z3

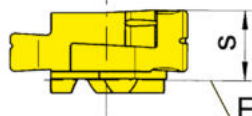
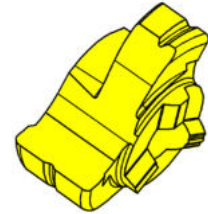
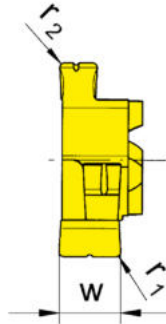
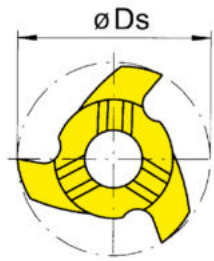

Fräaserschaft
Milling shank

Abbildung = rechtsschneidend
Picture = right hand cutting version

▲ ab Lager
on stock

HM-Sorten
Carbide grades
Δ 4 Wochen
4 weeks

Bestellnummer Part number	D_s	s	w	r_1	r_2	a	HIS	AS45	TI25
311.1016.00	17	7,7	7,2	0,5	0,8	10	311090R	▲	▲
								P ● ●	● ●
								M ● ●	● ●
								K ● ●	● ●
								N ○ ●	● ●
								S ● ●	● ●
								H - -	- -

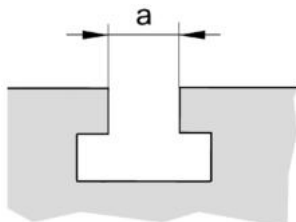



Abbildung = rechtsschneidend
Picture = right hand cutting version

▲ ab Lager
on stock

HM-Sorten
Carbide grades

Δ 4 Wochen
4 weeks

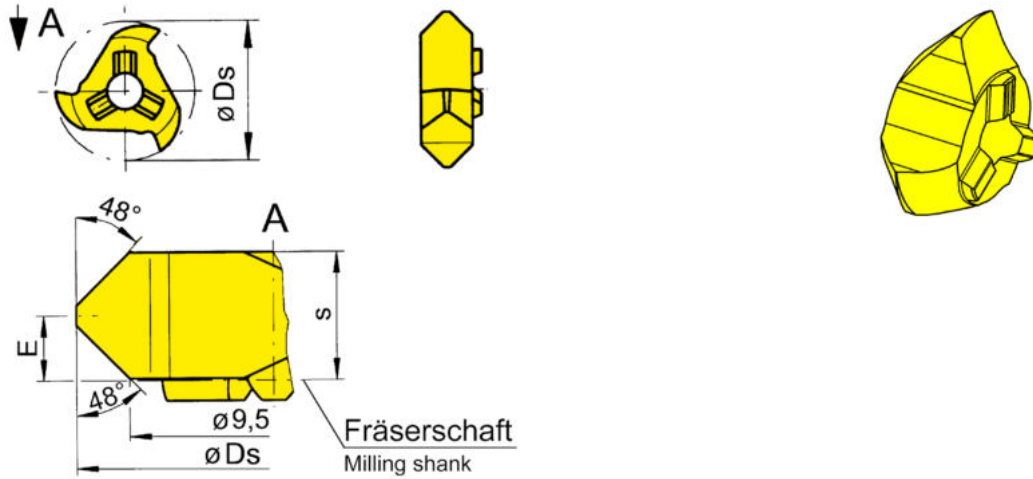
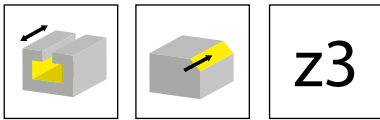
Bestellnummer Part number	Ds	E	s	a	HIS	T125
311.4216.00	15,8	3	5,95	10	311090R	▲

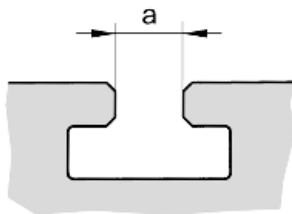

P	●
M	●
K	●
N	●
S	●
H	-

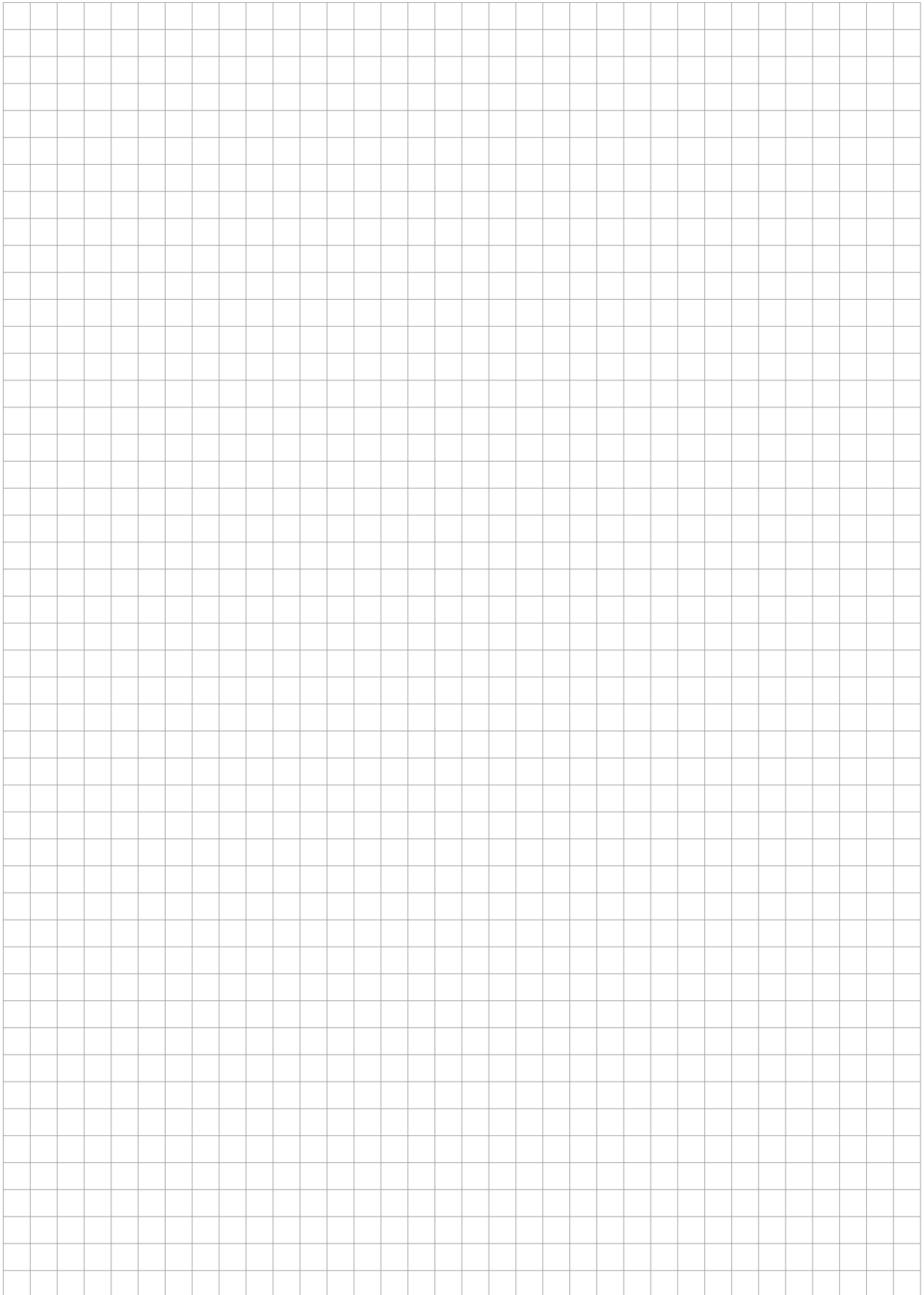

Frälerschaft
Milling shank
M313

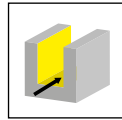

Seite/Page
418

Schneidplatte
Insert
313

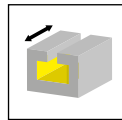

Seite/Page
419

M313



**T-Nuten-Fräser mit
wechselbarer
Schneidplatte**

ab Schneidkreis \varnothing 20 mm

**T-Slot Cutter
with exchangeable
inserts**

from cutting edge \varnothing 20 mm

J



Abbildung = rechtsschneidend
Picture = right hand cutting version

Bestellnummer Part number	d	l ₁	l ₂	d ₁	Form	HWS
M313.0016.00A	16	93	30	11,5	A	313113R • 313113L
M313.0016.00B	16	93	30	11,5	B	313113R • 313113L
M313.0016.00E	16	93	30	11,5	E	313113R • 313113L

Ds siehe Schneidplatten
Ds see inserts

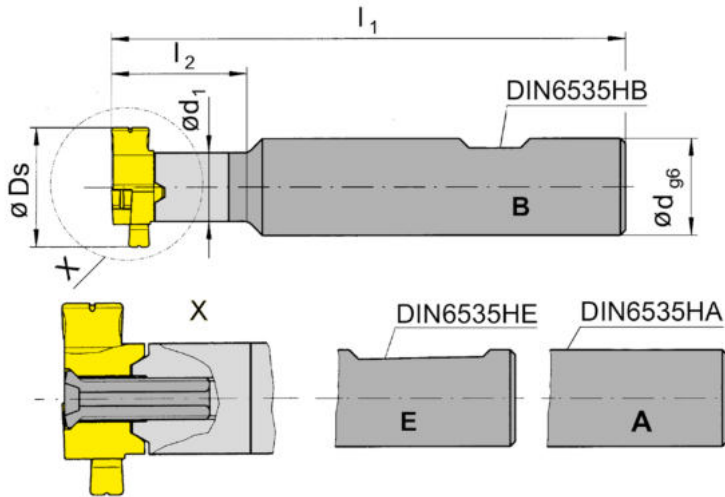
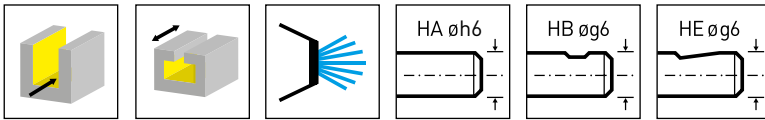

Ersatzteile
Spare Parts

Fräserschaft Milling shank	Spannschraube Clamping Screw	TORX PLUS®-Schlüssel TORX PLUS® Wrench
M313...	5.13T20KP	T20PQ

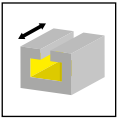

z3

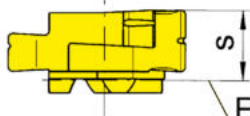
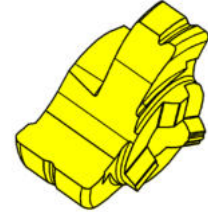
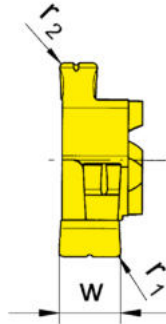
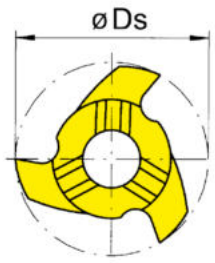

Fräuserschaft
Milling shank

Abbildung = rechtsschneidend
Picture = right hand cutting version

▲ ab Lager
on stock

HM-Sorten
Carbide grades
Δ 4 Wochen
4 weeks

Bestellnummer Part number	D_s	s	w	r_1	r_2	a	HIS	AS45	TI25
313.1219.00	20	8,7	8,2	0,5	0,8	12	313113R	▲	▲
								P ● ●	● ●
								M ● ●	● ●
								K ● ●	● ●
								N ○ ●	● ●
								S ● ●	● ●
								H - -	- -

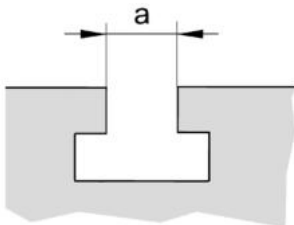

Fräserschaft
Milling shank
M328

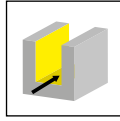

Seite/Page
422

Schneidplatte
Insert
328

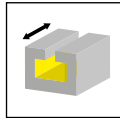

Seite/Page
423

Technische Hinweise
Technical Instructions

Seite/Page
424

M328



**T-Nuten-Fräser mit
wechselbarer
Schneidplatte**

ab Schneidkreis \varnothing 24 mm

**T-Slot Cutter
with exchangeable
inserts**

from cutting edge \varnothing 24 mm

J



Abbildung = rechtsschneidend
Picture = right hand cutting version

Bestellnummer Part number	d	l ₁	l ₂	d ₁	Form	HWS
M328.0020.00A	20	104	35	13,5	A	328143R
M328.0020.00B	20	104	35	13,5	B	328143R
M328.0020.00E	20	104	35	13,5	E	328143R

Ds siehe Schneidplatten
Ds see inserts

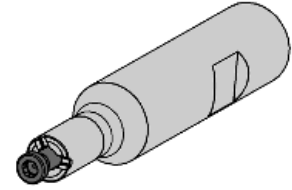
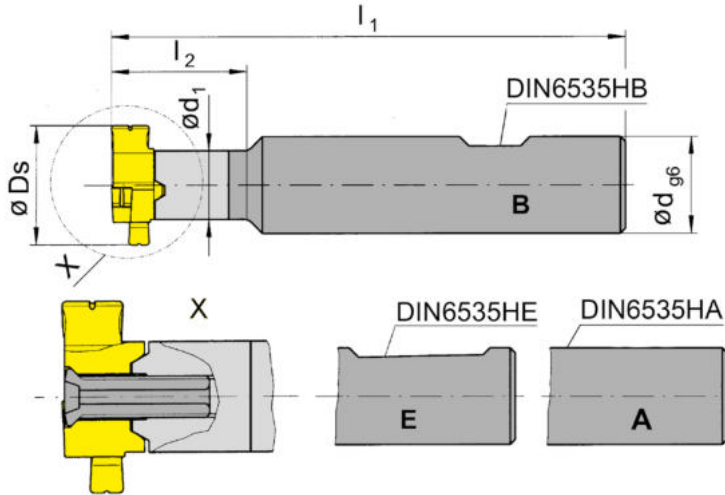
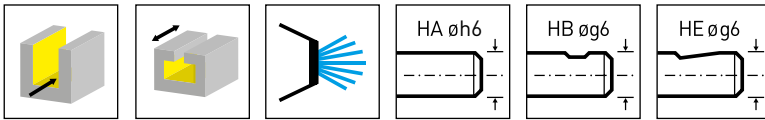

Ersatzteile
Spare Parts

Fräserschaft Milling shank	Spannschraube Clamping Screw	TORX PLUS®-Schlüssel TORX PLUS® Wrench
M328...	5.13T20KP	T20PQ

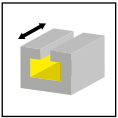

z3

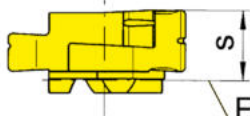
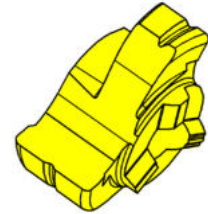
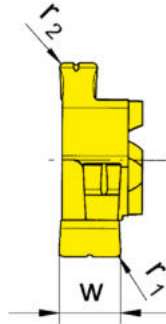
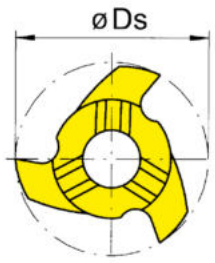

Fräuserschaft
Milling shank

Abbildung = rechtsschneidend
Picture = right hand cutting version

▲ ab Lager
on stock

HM-Sorten
Carbide grades
Δ 4 Wochen
4 weeks

Bestellnummer Part number	D_s	s	w	r_1	r_2	a	HIS	AS45	TI25
328.1423.00	24	9,8	9,2	0,5	1	14	328143R	▲	▲
								P ● ●	● ●
								M ● ●	● ●
								K ● ●	● ●
								N ○ ●	● ●
								S ● ●	● ●
								H - -	- -

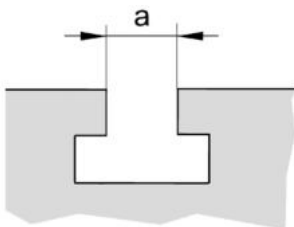

Anwendungstechnologie

Application Technology

$$a_2 \approx 0,2 \times s$$

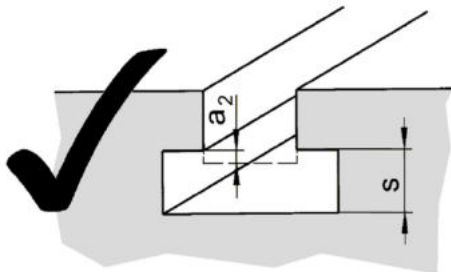

sehr empfehlenswert
 recommended

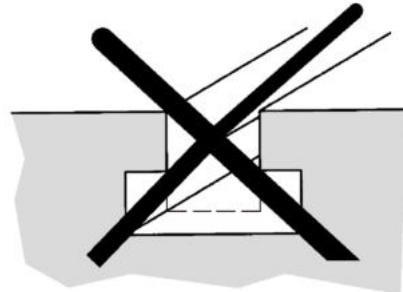

weniger empfehlenswert
 not recommended

Schnittdaten

Cutting data

T-Nuten-Fräsen

Milling of T-slots

bearbeitbare Werkstoffe Workpiece material	Schneidstoff Cutting material	v_c (m/min)	f_z (mm), Z=1 Ds 17 mm	f_z (mm), Z=1 Ds 20-24 mm
Kohlenstoffstahl Carbon steel	Tl25 / AS45	200 - 300	0,03 - 0,06	0,05 - 0,08
Legierter Stahl Alloyed steel	Tl25 / AS45	140 - 220	0,02 - 0,04	0,03 - 0,05
Grauguss Grey cast iron	Tl25 / AS45	100 - 160	0,03 - 0,06	0,05 - 0,10

T-Nuten-Fasen

Chamfering of T-slots

bearbeitbare Werkstoffe Workpiece material	Schneidstoff Cutting material	v_c (m/min)	f_z (mm), Z=3
Kohlenstoffstahl Carbon steel	Tl25 / AS45	300 - 400	0,10 - 0,13
Legierter Stahl Alloyed steel	Tl25 / AS45	180 - 300	0,13 - 0,21
Grauguss Grey cast iron	Tl25 / AS45	140 - 240	0,16 - 0,27

Diese Werte sind nur gültig mit dem zur Verfügung stehenden schwingungsdämpfenden Standard-Vollhartmetallschäften.

The cutting data is only valid for standard carbide toolholders (shanks) listed in this chapter.

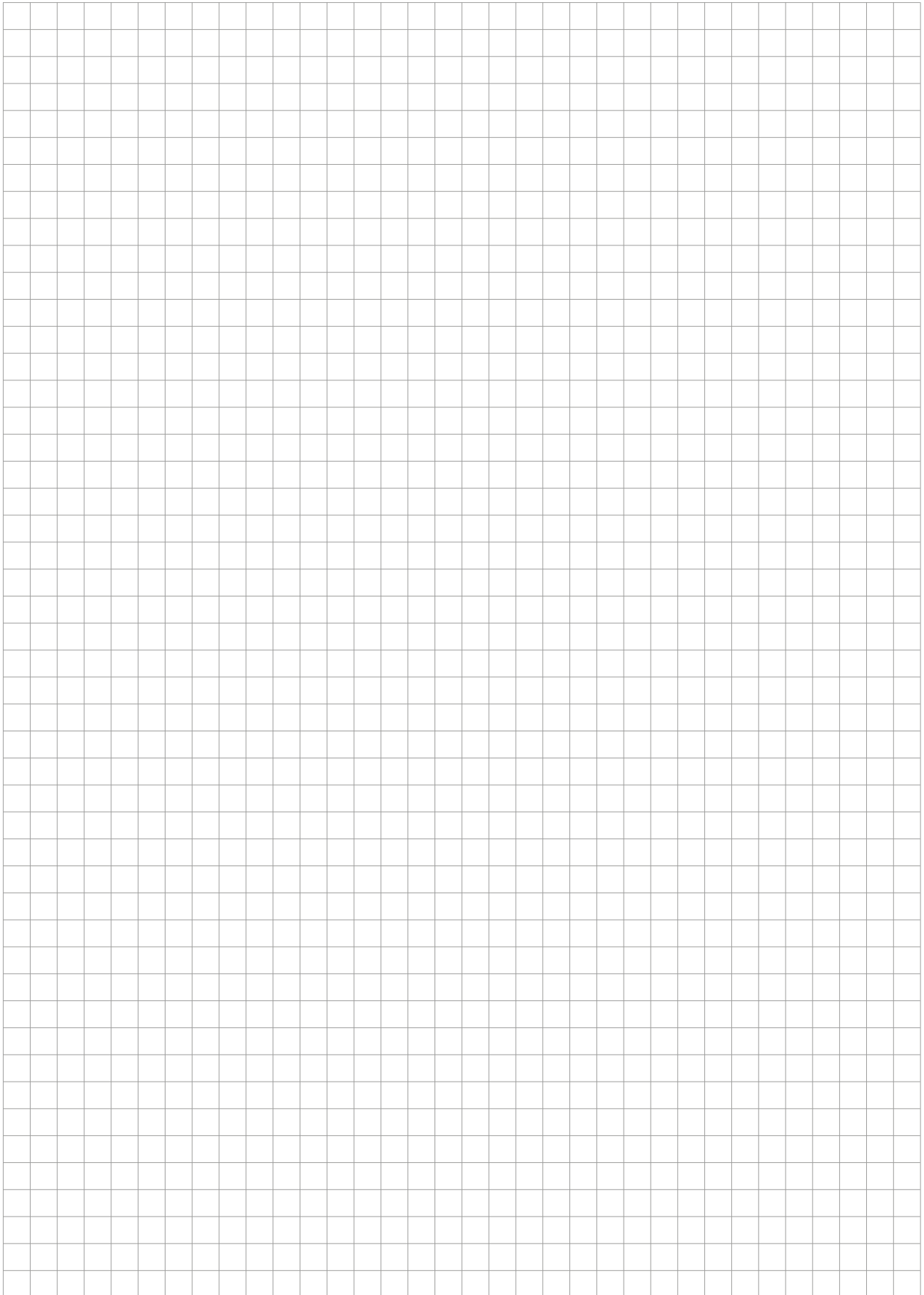

Schaftfräser
End Mill
M406/M409

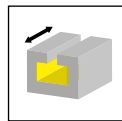

Seite/Page
428-429

Wendeschnidplatte
Indexable insert
406/409

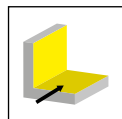

Seite/Page
430-431

Technische Hinweise
Technical Instructions

Seite/Page
432

M406/M409



**T-Nuten-Fräser mit
Wendeschneidplatten**

Schneidkreis-Ø 25-50 mm

**T-slots Cutter with
exchangeable inserts**

cutting edge Ø 25-50 mm

J



Abbildung = rechtsschneidend
Picture = right hand cutting version

Bestellnummer Part number	Z	Z _{eff}	Ds	d	l ₁	l ₂	d ₁	w	a	n _{max}	rechte WSP right hand insert	linke WSP left hand insert	HWS
M406.025.11.D16.1.02.B	4	2	25	16	83	31	12,4	11	12,9	19000	2x R406.063.U...	2x L406.063.U...	40600R • 40600L

ab Ø 25 mm 2 Spannflächen
from Ø 25 mm 2 clamping flats

J

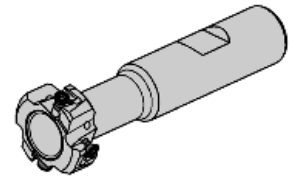
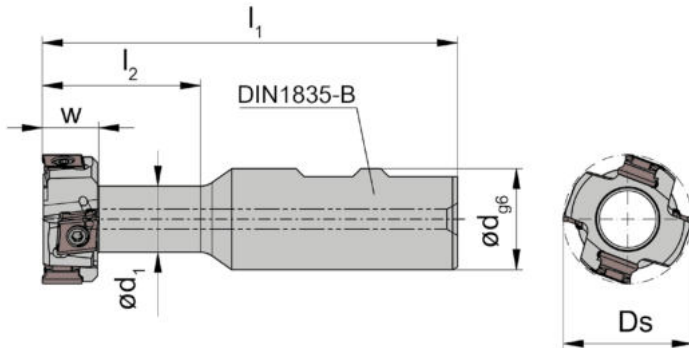
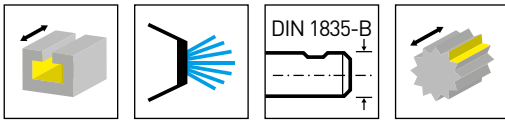
Ersatzteile

Spare Parts

Schaftfräser End Mill	Spannschraube Clamping Screw	TORX PLUS®-Schlüssel TORX PLUS® Wrench
M406.025.11.D16.1.02.B	030.2608.T8P	T8PL



Abbildung = rechtsschneidend
Picture = right hand cutting version

Bestellnummer Part number	Z	Z _{eff}	Ds	d	l ₁	l ₂	d ₁	w	a	n _{max}	rechte WSP right hand insert	linke WSP left hand insert	HWS
M409.032.14.D25.1.02.B	4	2	32	25	103	39	16,4	14	16,9	15600	2xR409.093.U...	2xL409.093.U...	40900R • 40900L
M409.040.18.D25.1.02.B	4	2	40	25	109	48	20,4	18	20,9	13900	2xR409.093.U...	2xL409.093.U...	40900R • 40900L
M409.050.22.D32.1.02.B	6	2	50	32	125	59	26,4	22	26,9	12500	4xR409.093.U...	2xL409.093.U...	40900R • 40900L

ab Ø 25 mm 2 Spannflächen
from Ø 25 mm 2 clamping flats

Ersatzteile
Spare Parts

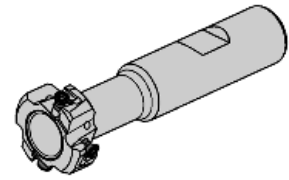
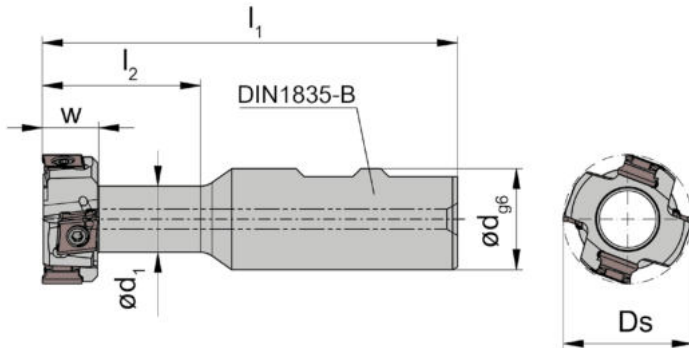
Schaftfräser End Mill	Spannschraube Clamping Screw	TORX PLUS®-Schlüssel TORX PLUS® Wrench
M409...	030.3511.T10P	T10PL

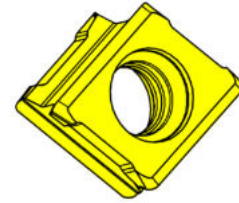
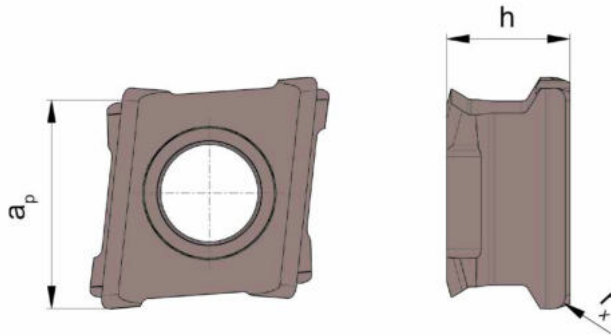
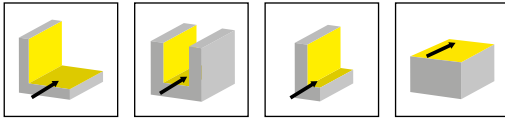

HM-Sorten
Carbide grades

▲ ab Lager
on stock

△ 4 Wochen
4 weeks

Bestellnummer Part number	a _p	h	r _x	HIS	HM-Sorten Carbide grades	
					AS46	AS4B
R406.063.U.02	6,3	3,85	0,2	40600R	△	▲
R406.063.U.04	6,3	3,85	0,4	40600R	▲	▲
R406.063.U.08	6,3	3,85	0,8	40600R	▲	▲
L406.063.U.02	6,3	3,85	0,2	40600L	△	▲
L406.063.U.04	6,3	3,85	0,4	40600L	▲	▲
L406.063.U.08	6,3	3,85	0,8	40600L	▲	▲
					P	○ ●
					M	○ ●
					K	● ●
					N	○ ○
					S	○ ●
					H	- -

mit 4 nutzbaren Schneidkanten
with 4 usable cutting edges

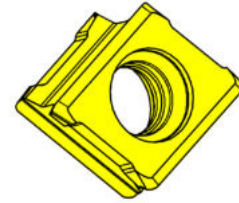
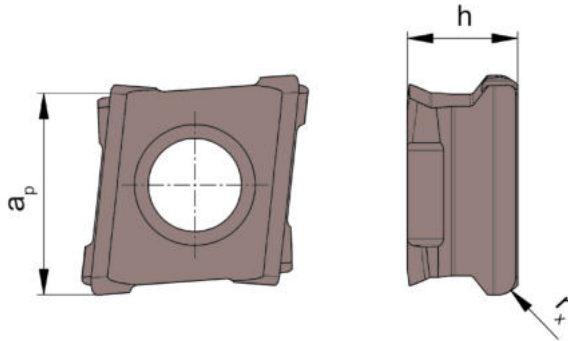
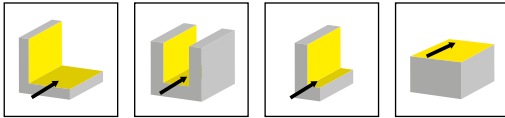

HM-Sorten
Carbide grades

▲ ab Lager
on stock

Δ 4 Wochen
4 weeks

Bestellnummer Part number	a _p	h	r _x	HIS	HM-Sorten Carbide grades	
					AS46	AS4B
R409.093.U.04	9,3	5,2	0,4	40900R	▲	▲
R409.093.U.08	9,3	5,2	0,8	40900R	▲	▲
R409.093.U.12	9,3	5,2	1,2	40900R	▲	▲
L409.093.U.04	9,3	5,2	0,4	40900L	▲	▲
L409.093.U.08	9,3	5,2	0,8	40900L	▲	▲
L409.093.U.12	9,3	5,2	1,2	40900L		▲
					P	o ●
					M	o ●
					K	● ●
					N	o o
					S	o ●
					H	- -

mit 4 nutzbaren Schneidkanten
with 4 usable cutting edges



Anwendungstechnologie

Application Technology

$$a_2 \approx 0,2 \times s$$

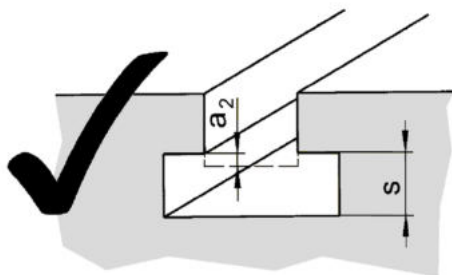

sehr empfehlenswert
recommended

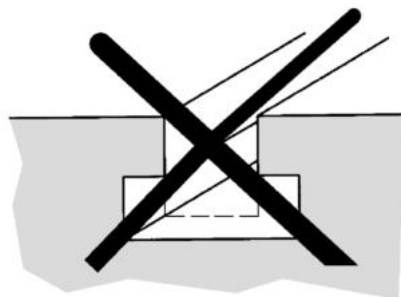

weniger empfehlenswert
not recommended

Schnittdaten

Cutting Data

T-Nuten-Fräsen Ø25 / Ø32 mm

Milling of T-Slots

bearbeitbare Werkstoffe Workpiece material	Schneidstoff Cutting material	v_c (m/min)	f_z (mm)
Vergütungsstahl heat-treatable steel	AS4B	120 - 160	0,07 - 0,14
Grauguss Grey cast iron	AS4B	100 - 160	0,07 - 0,14

T-Nuten-Fräsen Ø40 / Ø50 mm

Milling of T-Slots

bearbeitbare Werkstoffe Workpiece material	Schneidstoff Cutting material	v_c (m/min)	f_z (mm)
Vergütungsstahl heat-treatable steel	AS4B	60 - 90	0,06 - 0,08
Grauguss Grey cast iron	AS4B	90 - 140	0,06 - 0,08



System/System

Seite/Page

M275

434

381

440

Schlagmesser
Cutter
M275

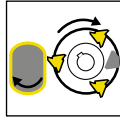

Seite/Page
436-437

Wendeschneidplatte
Indexable insert
S275

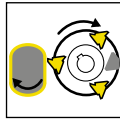

Seite/Page
438

M275



Schlagmesser

ab Schneidkreis \varnothing 40 mm

Cutter

from cutting edge \varnothing 40 mm



Abbildung = linksschneidend
Picture = left hand cutting version

Bestellnummer Part number	Ds	d ₂	h	t _{max}	d ₄	d ₃	Maschinentyp Machine type	HWS
RM275.D040.10.04	40	33	7,9	3	10	15,5	EvoDECO 10	275041R
LM275.D040.10.04	40	33	7,9	3	10	15,5	EvoDECO 10	275041L

für Maschine: Tornos
for machine: Tornos

K

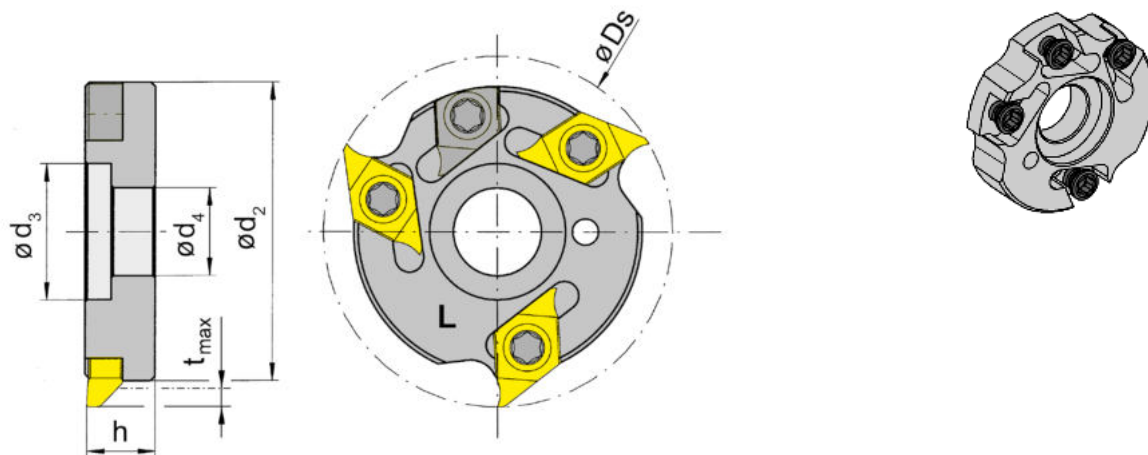
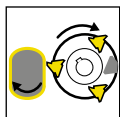
Ersatzteile

Spare Parts

Schlagmesser Cutter	Spannschraube Clamping Screw	TORX PLUS®-Schlüssel TORX PLUS® Wrench	Wuchtelement links Left hand balancing element	Wuchtelement rechts Right hand balancing element
LM275.D040.10.04	030.357P.0315	T10PL	LS275.AT41.HM	
RM275.D040.10.04	030.357P.0315	T10PL		RS275.AT41.HM



Abbildung = rechtsschneidend
Picture = right hand cutting version

Bestellnummer Part number	Ds	d ₂	h	t _{max}	d ₄	d ₃	Maschinentyp Machine type	HWS
RM275.T064.3325.03	64	56	36	3	10	15,5	EvoDECO 10	275041R

für Maschine: **Tornos**
for machine: Tornos

Ersatzteile
Spare Parts

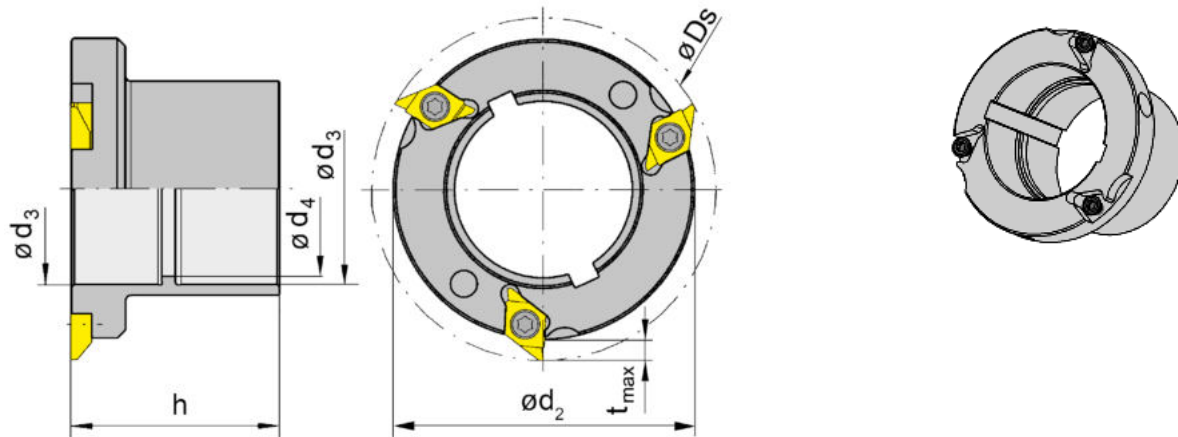
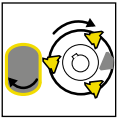
Schlagmesser Cutter	Spannschraube Clamping Screw	TORX PLUS®-Schlüssel TORX PLUS® Wrench
RM275.T064.3325.03	3.5.10T10P	T10PL

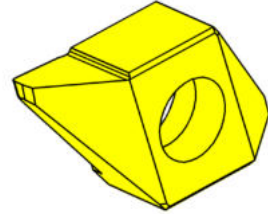
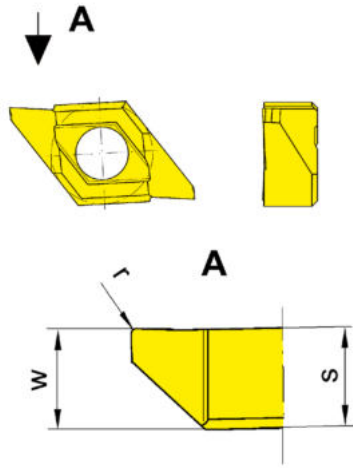
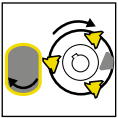

R = rechts wie gezeichnet
R = right hand version shown

L = links spiegelbildlich
L = left hand version

▲ ab Lager
on stock

HM-Sorten
Carbide grades
Δ 4 Wochen
4 weeks

Bestellnummer Part number	w	r	s	HIS	MG12	AS45	TI25
RS275.MK13.M0	1,3	0,2	3,9	275041R	Δ	▲	▲
LS275.MK13.M0	1,3	0,2	3,9	275041L	Δ	▲	▲
					P	o	•
					M	-	•
					K	-	•
					N	-	o
					S	-	•
					H	-	-

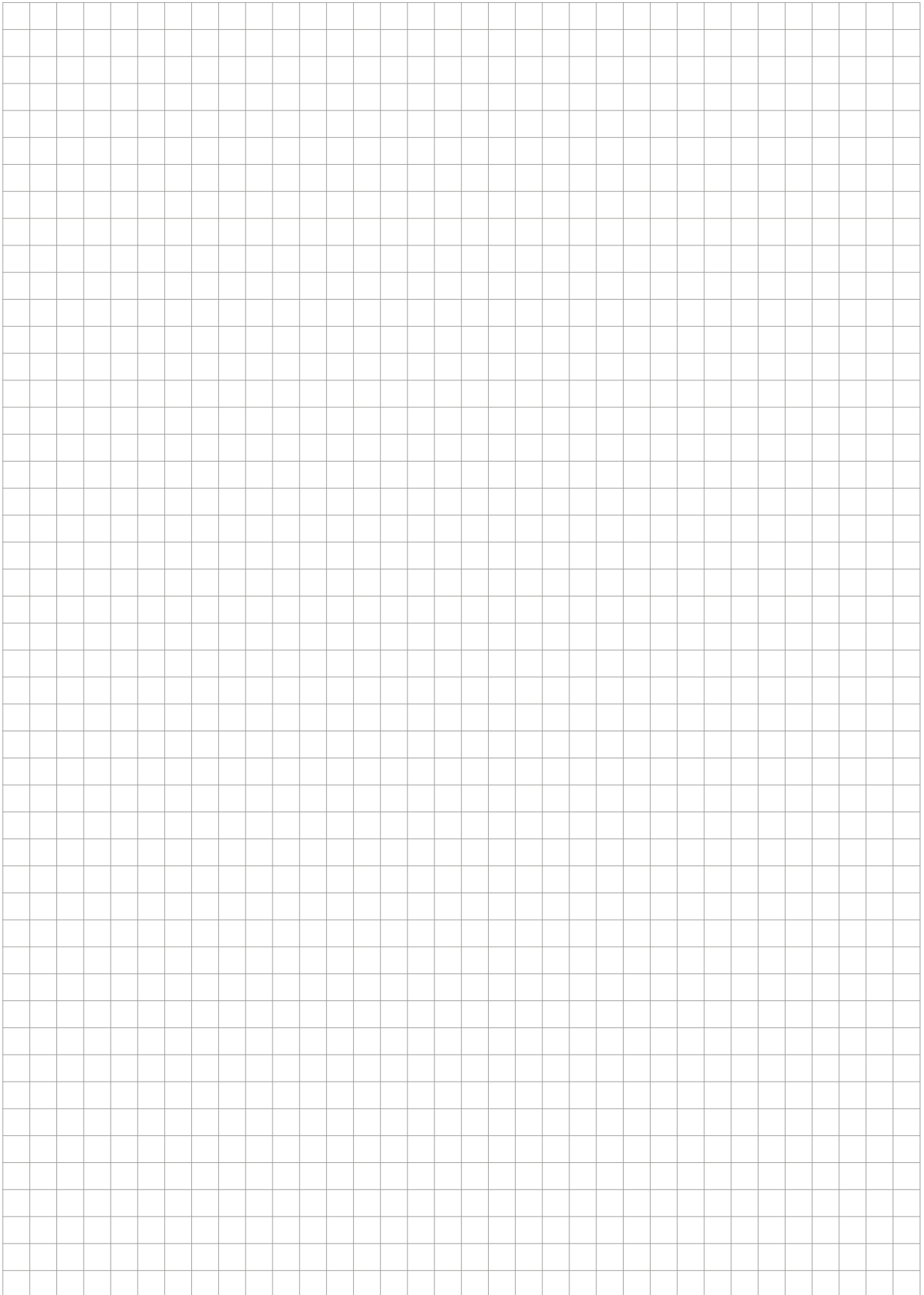

Schlagmesser
Cutter
381

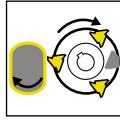

Seite/Page
442-454

Wendeschneidplatte
Indexable insert
N314/314

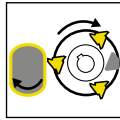

Seite/Page
455-456

Technische Hinweise
Technical Instructions

Seite/Page
457-462

Übersicht
Overview

Seite/Page
463-464

381



Schlagmesser

ab Schneidkreis \varnothing 60 mm

Cutter

from cutting edge \varnothing 60 mm

K



Abbildung = linksschneidend
Picture = left hand cutting version

Bestellnummer Part number	D_s	d_2	h	t_{max}	d_3	Maschinentyp Machine type	HWS
L381.A060.13.04	60	50	8,2	4,5	13	Star SR-20J	314027N

für Maschine: **Star**
for machine: Star

Ersatzteile
Spare Parts

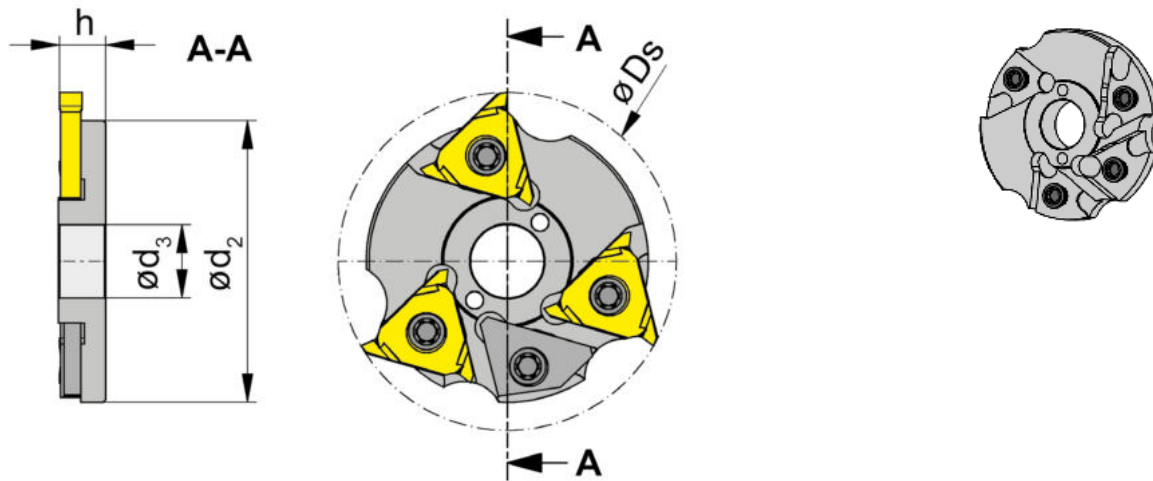
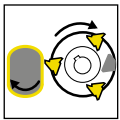
Schlagmesser Cutter	Spannschraube Clamping Screw	TORX PLUS®-Schlüssel TORX PLUS® Wrench	Wuchtelement links Left hand balancing element
L381.A060.13.04	5F.08T20P	T20PQ	L314.AT30.HM



Abbildung = linksschneidend
Picture = left hand cutting version

Bestellnummer Part number	D _s	d ₂	h	α	t _{max}	d ₃	Maschinentyp Machine type	HWS
L381.G070.15.04	70	58	15	8,16°	5	11,5	GLD25/GD32	314041L
L381.G086.25.04	86	74	23	8,16°	5	18	GM20-6,-35-8/GMC35	314041L
L381.G098.26.04	98	86	23	8,32°	5	20	GM35-6,-35-8,-42-6/GMC35	314041L

für Maschine: **Gildemeister**
for machine: Gildemeister

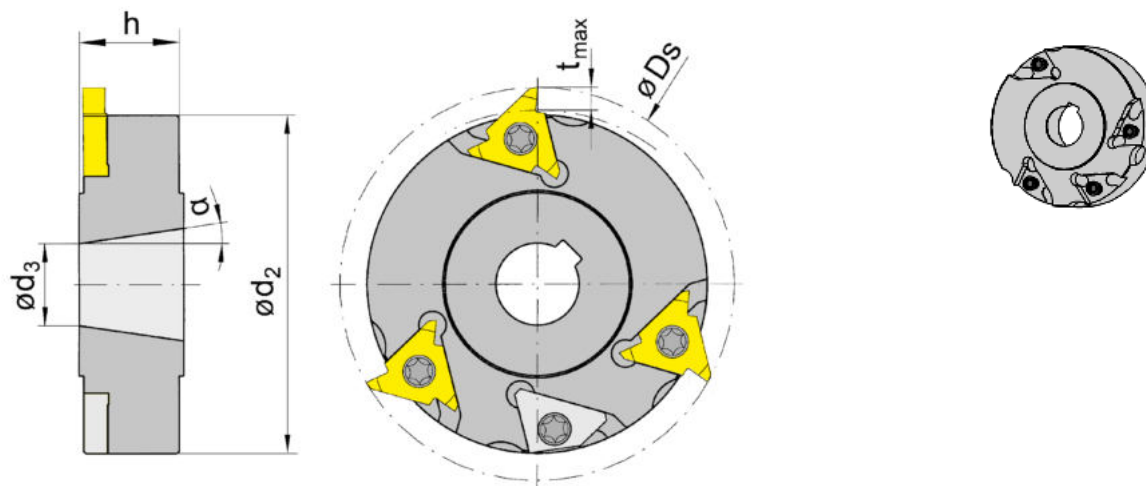
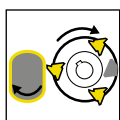

Ersatzteile Spare Parts

Schlagmesser Cutter	Spannschraube Clamping Screw	TORX PLUS®-Schlüssel TORX PLUS® Wrench	Wuchtelement Balancing element
L381.G070.15.04	5.10T20P	T20PQ	N314.AT40.HM
L381.G...	5.12T20P	T20PQ	N314.AT40.HM



Abbildung = linksschneidend
Picture = left hand cutting version

Bestellnummer Part number	Ds	d ₂	h	t _{max}	d ₃	Maschinentyp Machine type	HWS
L381.G080.16.04	80	68	9	5	16	SPRINT 20/32	314027N

für Maschine: **Gildemeister**
for machine: Gildemeister

K

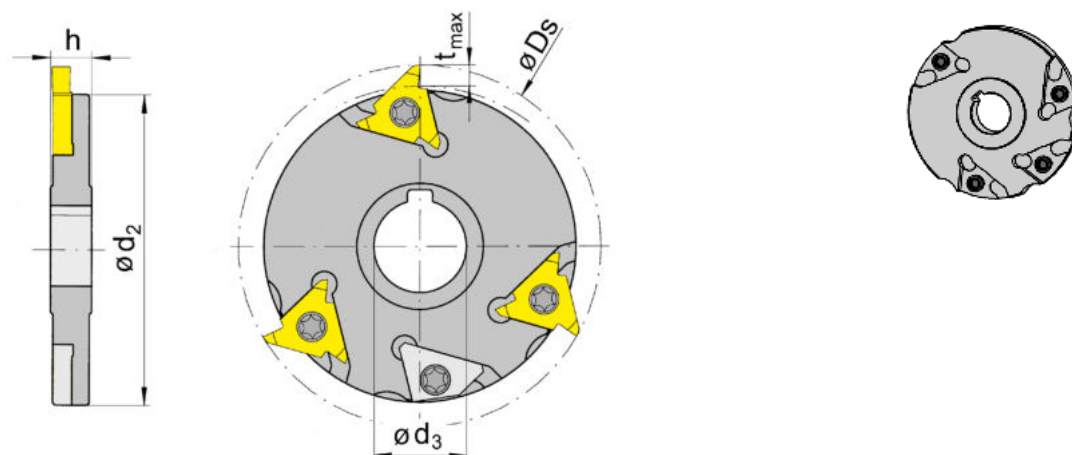
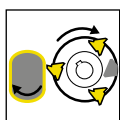
Ersatzteile
Spare Parts

Schlagmesser Cutter	Spannschraube Clamping Screw	TORX PLUS®-Schlüssel TORX PLUS® Wrench	Wuchtelement links Left hand balancing element
L381.G080.16.04	5F.08T20P	T20PQ	L314.AT30.HM



Abbildung = linksschneidend
Picture = left hand cutting version

Bestellnummer Part number	Ds	d ₂	h	t _{max}	d ₄	d ₃	Maschinentyp Machine type	HWS
L381.G090.22.04	90	78	20	5	22	30	SPRINT 32L/-42L	314041L

für Maschine: **Gildemeister**
for machine: Gildemeister

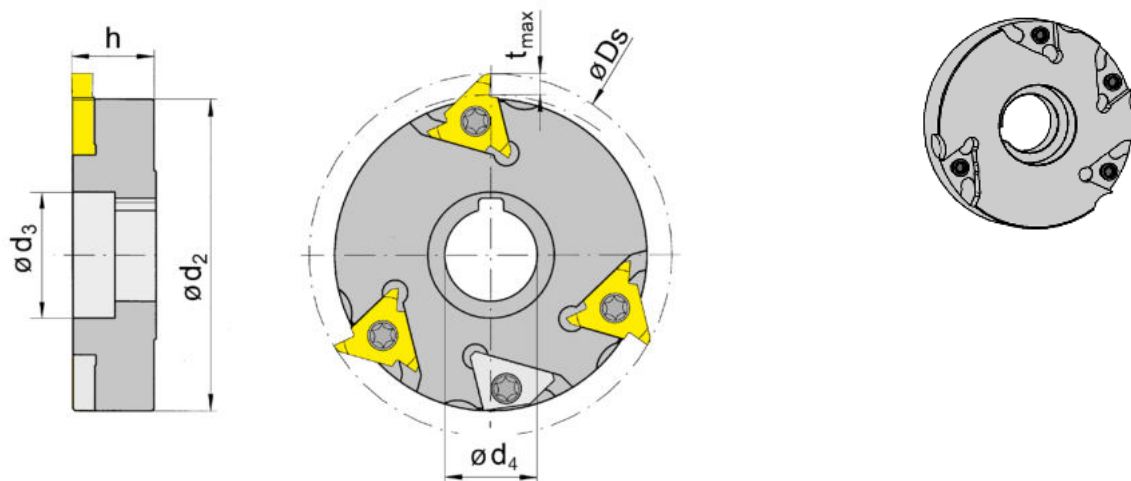
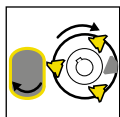

Ersatzteile Spare Parts

Schlagmesser Cutter	Spannschraube Clamping Screw	TORX PLUS®-Schlüssel TORX PLUS® Wrench	Wuchtelement Balancing element
L381.G090.22.04	5.12T20P	T20PQ	N314.AT40.HM



Abbildung = rechtsschneidend
Picture = right hand cutting version

Bestellnummer Part number	Ds	d ₂	h	t _{max}	d ₃	Maschinentyp Machine type	HWS
R381.X090.27.04	90	78	16,2	5	27	Index ABC	314041R
L381.X090.27.04	90	78	16,2	5	27	Index ABC	314041L

für Maschine: **INDEX**
for machine: INDEX

K

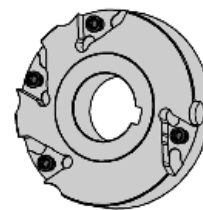
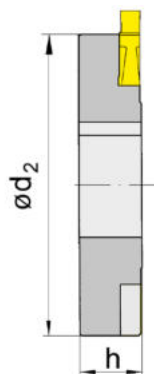
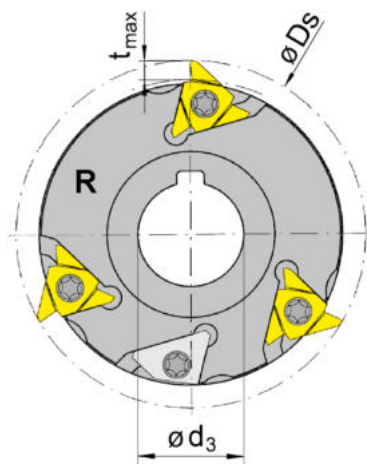
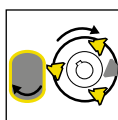
Ersatzteile Spare Parts

Schlagmesser Cutter	Spannschraube Clamping Screw	TORX PLUS®-Schlüssel TORX PLUS® Wrench	Wuchtelement Balancing element
R/L381.X090.27.04	5.12T20P	T20PQ	020.0314.1531



Abbildung = rechtsschneidend
Picture = right hand cutting version

Bestellnummer Part number	D_s	d_2	h	t_{max}	d_3	Maschinentyp Machine type	HWS
R381.X073.16.04	73,5	63,5	8	5	16	Index MS25	314027N

für Maschine: **INDEX**
for machine: INDEX

Ersatzteile Spare Parts

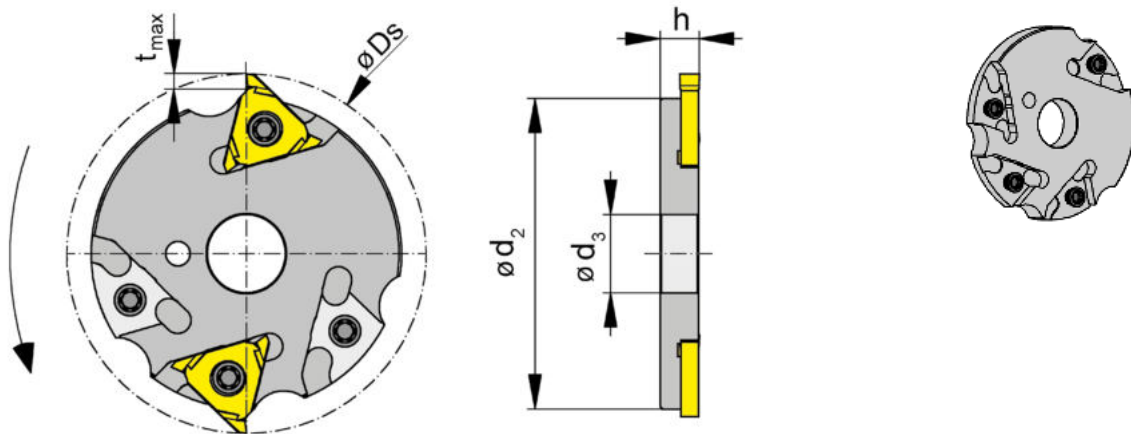
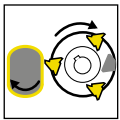
Schlagmesser Cutter	Spannschraube Clamping Screw	TORX PLUS®-Schlüssel TORX PLUS® Wrench	Wuchtelement rechts Right hand balancing element
R381.X073.16.04	5F.08T20P	T20PQ	R314.AT30.HM



Abbildung = linksschneidend
Picture = left hand cutting version

Bestellnummer Part number	D_s	d_2	h	t_{max}	d_3	Maschinentyp Machine type	HWS
L381.N090.16.04	90	80	7,8	5	16	WT250	314027N

für Maschine: **Nakamura**
for machine: Nakamura

K

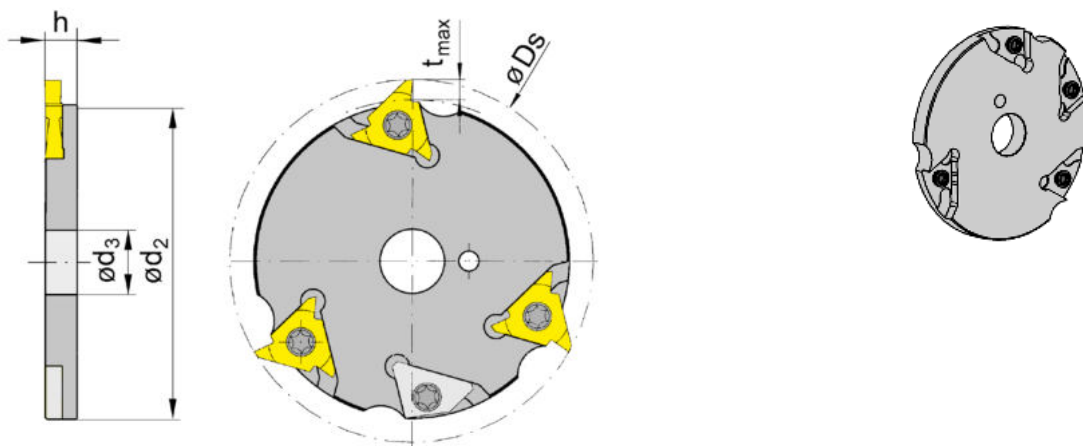
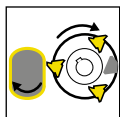
Ersatzteile Spare Parts

Schlagmesser Cutter	Spannschraube Clamping Screw	TORX PLUS®-Schlüssel TORX PLUS® Wrench	Wuchtelement links Left hand balancing element
L381.N090.16.04	5F.08T20P	T20PQ	L314.AT30.HM



Abbildung = linksschneidend
Picture = left hand cutting version

Bestellnummer Part number	D _s	d ₂	h	α	*t _{max}	d ₃	Maschinentyp Machine type	HWS
L381.S078.30.02	78	66	19	5,42°	5	26,3	SG18, SG20, AG18	314052L
L381.S098.30.02	98	94,6	19	5,42°	5	26,3	SG20/SF26,-S,-L/SE18/AF26,32	314052L
L381.S118.30.02	118	115	19	5,42°	5	26,3	SF32,42,51,67/AF42	314052L

für Maschine: **A.H. Schütte**
for machine: A.H. Schütte

geschlossener Plattensitz, Vorschub in Axialrichtung
reinforced pocket, feed in axial direction

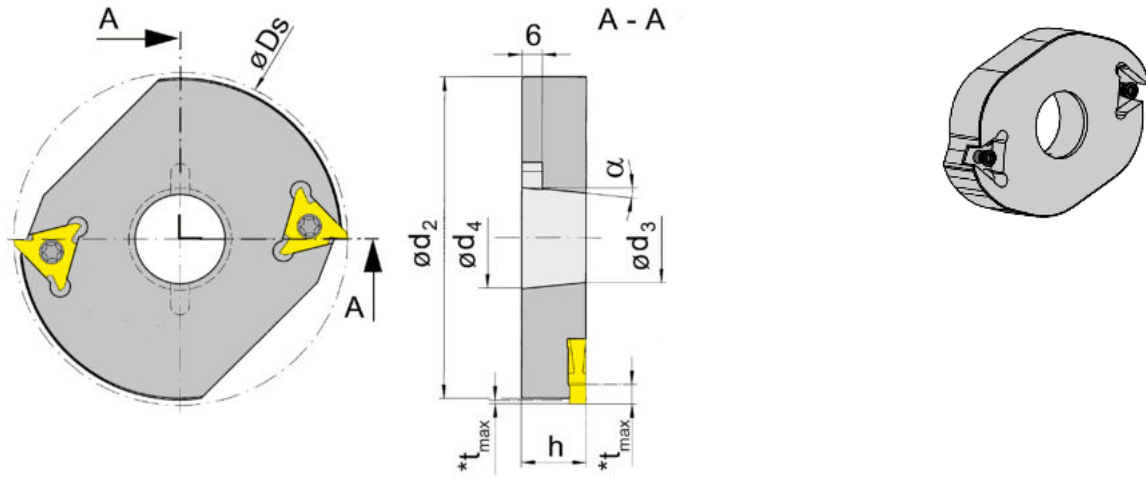
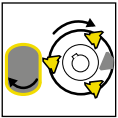
* t_{max} Längsfräsen = 5,0 mm / Einstechfräsen = 1,2 mm
* t_{max} Side Milling = 5,0 mm / Groove Milling = 1,2 mm



Ersatzteile
Spare Parts

Schlagmesser Cutter	Spannschraube Clamping Screw	TORX PLUS®-Schlüssel TORX PLUS® Wrench
L381...	5.15T20P	T20PQ



Abbildung = linksschneidend
Picture = left hand cutting version

Bestellnummer Part number	D_s	d_2	h	α	$*t_{max}$	d_3	Maschinentyp Machine type	HWS
L381.S078.30.03	78	77	19	5,42°	5	26,3	SG18, SG20, AG18	314052L
L381.S098.30.03	98	94,6	19	5,42°	5	26,3	SG20/SF26,-S,-L/SE18/AF26,32	314052L
L381.S118.30.03	118	115	19	5,42°	5	26,3	SF32,42,51,67/AF42	314052L

für Maschine: **A.H. Schütte**
for machine: A.H. Schütte

geschlossener Plattensitz, Vorschub in Axialrichtung
reinforced pocket, feed in axial direction

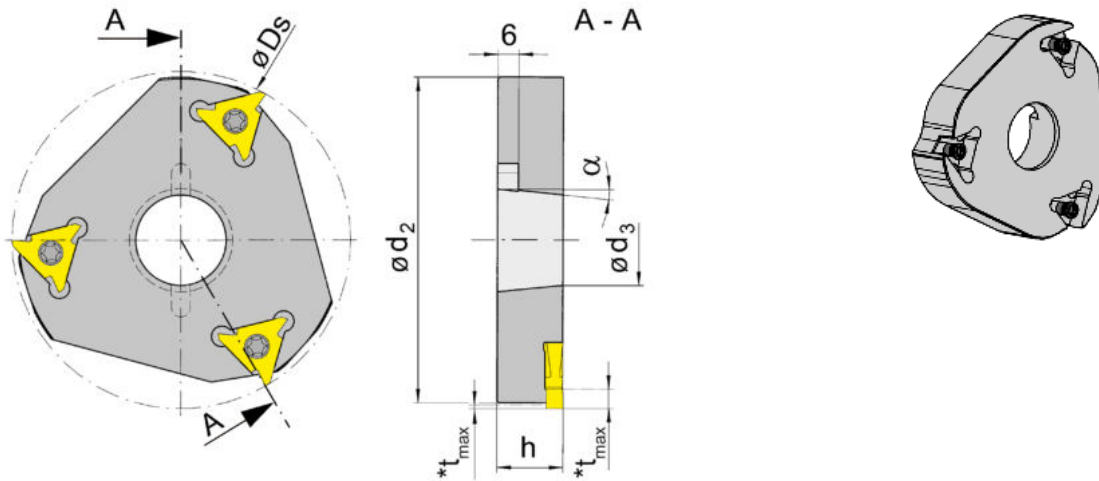
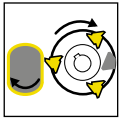
* t_{max} Längsfräsen = 5,0 mm / Einstechfräsen = 1,2 mm
* t_{max} Side Milling = 5,0 mm / Groove Milling = 1,2 mm

Ersatzteile
Spare Parts

Schlagmesser Cutter	Spannschraube Clamping Screw	TORX PLUS®-Schlüssel TORX PLUS® Wrench
L381...	5.15T20P	T20PQ



Abbildung = linksschneidend
Picture = left hand cutting version

Bestellnummer Part number	D_s	d_2	h	t_{max}	d_4	d_3	Maschinentyp Machine type	HWS
L381.D080.16.04	80	57,5	13,6	5	16	23	DECO 2000/DECO 13/20/26	314027N

für Maschine: **Tornos**
for machine: Tornos

Ersatzteile
Spare Parts

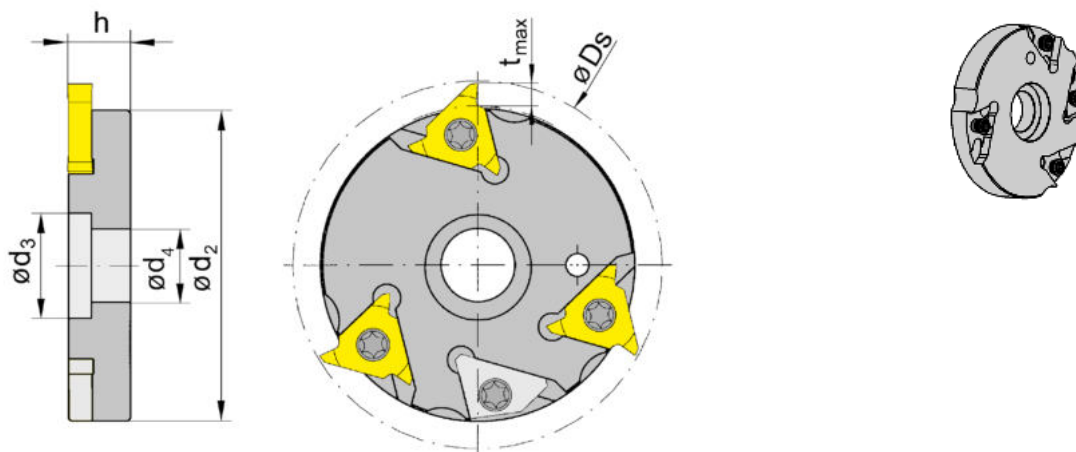
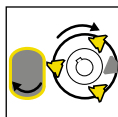
Schlagmesser Cutter	Spannschraube Clamping Screw	TORX PLUS®-Schlüssel TORX PLUS® Wrench	Wuchtelement links Left hand balancing element
L381.D080.16.04	5F.08T20P	T20PQ	L314.AT30.HM



Abbildung = linksschneidend
Picture = left hand cutting version

Bestellnummer Part number	Ds	d ₂	h	t _{max}	d ₄	d ₃	Maschinentyp Machine type	HWS
L381.D086.25.04	86	74	23	5	24,7	18	Tornos Multi-Deco	314041L

für Maschine: **Tornos**
for machine: Tornos

K

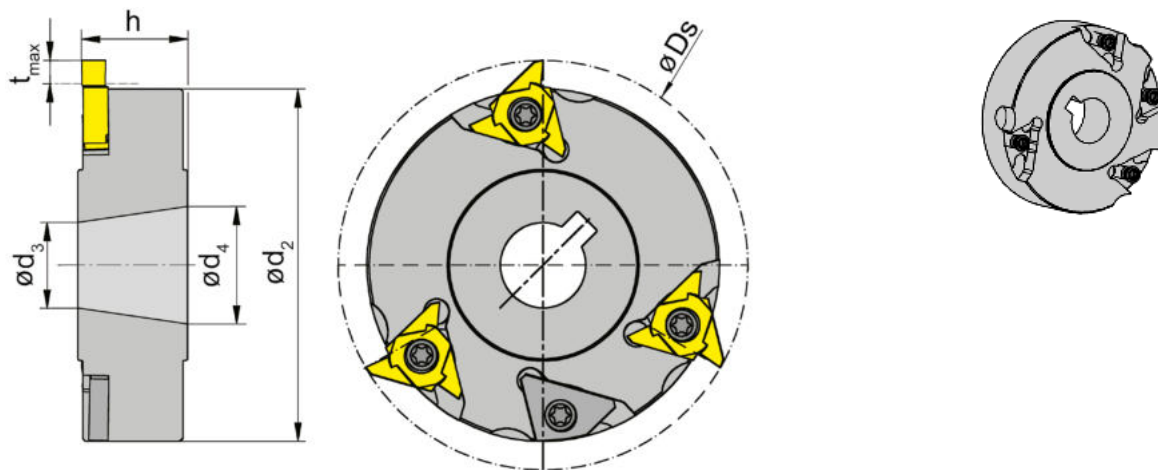
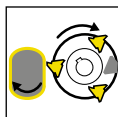
Ersatzteile Spare Parts

Schlagmesser Cutter	Spannschraube Clamping Screw	TORX PLUS®-Schlüssel TORX PLUS® Wrench	Wuchtelement Balancing element
L381.D086.25.04	5.12T20P	T20PQ	N314.AT40.HM



Abbildung = rechtsschneidend
Picture = right hand cutting version

Bestellnummer Part number	Ds	d ₂	h	t _{max}	d ₃	Maschinentyp Machine type	HWS
R381.T080.16.04	80	69	12	5	16	TRAUB TNL18	314027N

für Maschine: **Traub**
for machine: Traub

Ersatzteile
Spare Parts

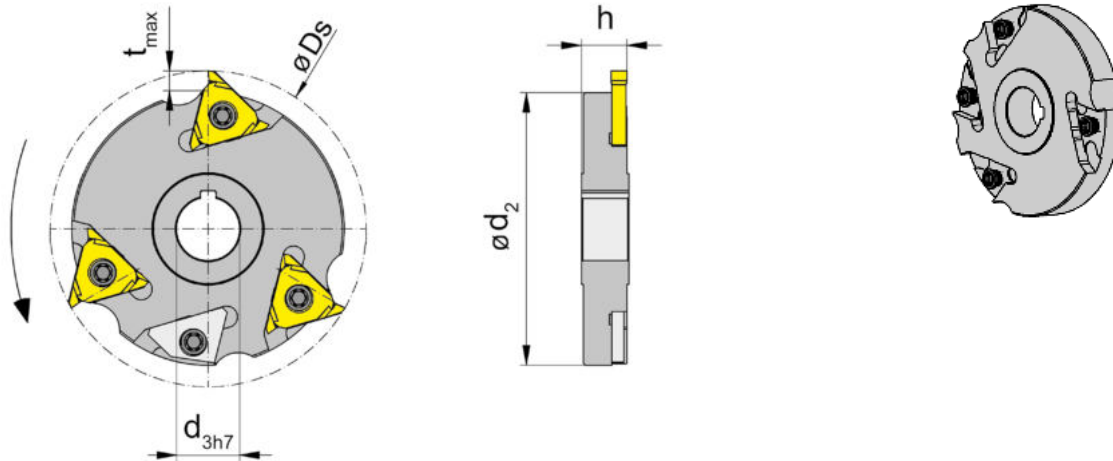
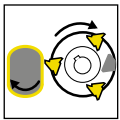
Schlagmesser Cutter	Spannschraube Clamping Screw	TORX PLUS®-Schlüssel TORX PLUS® Wrench	Wuchtelement rechts Right hand balancing element
R381.T080.16.04	5F.08T20P	T20PQ	R314.AT30.HM



Abbildung = linksschneidend
Picture = left hand cutting version

Bestellnummer Part number	Ds	d ₂	h	t _{max}	d ₃	Maschinentyp Machine type	HWS
L381.T069.12.04	69	57,5	8	5	12	TNL12-7/TNL26/TNK36	314027N

für Maschine: **Traub**
for machine: Traub

K

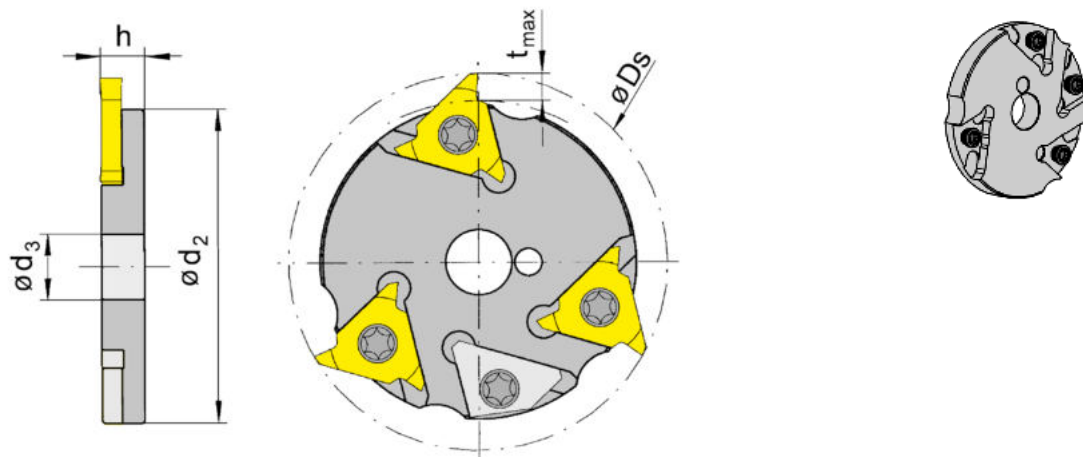
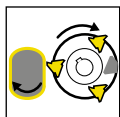
Ersatzteile
Spare Parts

Schlagmesser Cutter	Spannschraube Clamping Screw	TORX PLUS®-Schlüssel TORX PLUS® Wrench	Wuchtelement links Left hand balancing element
L381.T069.12.04	5F.08T20P	T20PQ	L314.AT30.HM

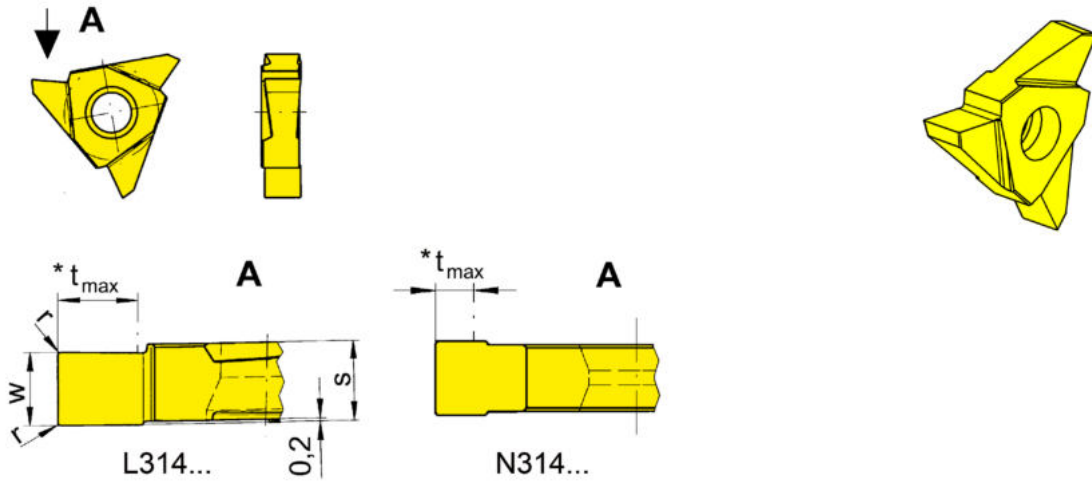
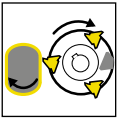

HM-Sorten
Carbide grades

▲ ab Lager
on stock

△ 4 Wochen
4 weeks

Bestellnummer Part number	w	r	s	t _{max}	HIS	MG12	AS45	TI25	TN35
R314.MK50.20	5	0,15	5,2	5	314041R		▲	▲	
L314.MK50.20	5	0,15	5,2	5	314041L		▲	▲	
L314.MK70.M0	7	0,15	7,4	-	314052L		▲	▲	▲
N314.MK40.20	4	-	3,6	-	314027N	▲	▲	▲	△
						P	o	•	•
						M	-	•	•
						K	-	•	•
						N	-	o	•
						S	-	•	•
						H	-	-	-

t _{max}	Einstecken Groove Milling	Längsfräsen Side Milling
N314.MK40.20	siehe Fräser/see cutter	2,5
R/L314.MK50.20	siehe Fräser/see cutter	5
L314.MK70.M0	siehe Fräser/see cutter	5



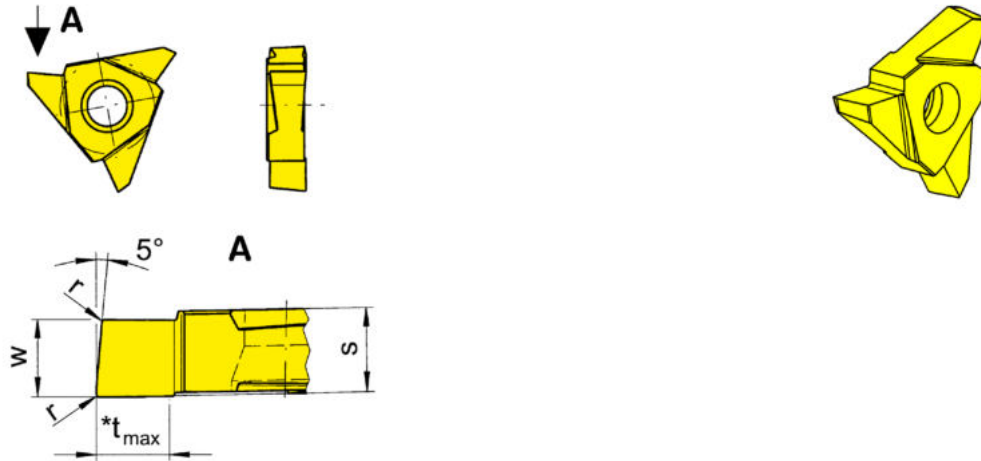
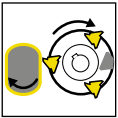

L = links wie gezeichnet
L = left hand version shown

R = rechts spiegelbildlich
R = right hand version

▲ ab Lager
on stock

HM-Sorten
Carbide grades
Δ 4 Wochen
4 weeks

Bestellnummer Part number	w	r	s	t _{max}	HIS	AS45	TH35	TI25
R314.MK50.5.20	5	0,15	5,4	5	314041R	▲		▲
R314.MK50.20.L	5,4	0,6	5,4	5	314041R	▲	Δ	▲
L314.MK50.5.20	5	0,15	5,4	5	314041L	▲		▲
L314.MK50.20.L	5,4	0,6	5,4	5	314041L	▲		▲
P	•	•	•					
M	•	•	•					
K	•	•	•					
N	o	•	•					
S	•	•	•					
H	-	-	-					

Funktionsprinzip des Mehrkantschlagens

Beim Mehrkantschlagen auf der Drehmaschine werden Flächen am Umfang (Mantelfläche) der Drehteile mit einem Schlagmesser erzeugt. Das Werkstück (Hauptspindel) und das Werkzeug (rotierender Werkzeugantrieb) müssen in einem synchronen Übersetzungsverhältnis laufen.

Mehrkantschlagen wird nur im Gegenlauf ausgeführt!

Die Anzahl der erzeugten Flächen am Werkstück steht in Abhängigkeit vom Übersetzungsverhältnis zwischen dem Werkstück und dem Werkzeug sowie der Anzahl der Schneiden des Werkzeugs.

Bei einem Übersetzungsverhältnis von 2:1 wird eine leicht konvexe Oberfläche erzielt. Die geringe Formabweichung ist für Flächen zweiter Ordnung (Schlüsselflächen) brauchbar. Bei einem Übersetzungsverhältnis von 1:1 ergeben sich stark konvexe Flächen, die für Schlüsselflächen nicht zu empfehlen sind. Bei einem Übersetzungsverhältnis von 3:1 werden stark konkave Flächen erzeugt, die ebenfalls für Schlüsselflächen nicht zu empfehlen sind.

Demzufolge wird in den meisten Fällen das Übersetzungsverhältnis 2:1 angewendet. Schlagmesser mit $Z = 2$ erzeugen 4 Flächen am Werkstück.

Zur Berechnung der Konvexität der erzeugten Flächen sind folgende Punkte notwendig:

1. Schneidkreisdurchmesser des Schlagmessers
2. Zu erzeugende Schlüsselweite
3. Vorgegebener Werkstückdurchmesser
4. Anzahl der Flächen
5. Übersetzungsverhältnis Werkstück:Werkzeug

Die Flächen können im Einstechverfahren sowie im Längsdrehverfahren erzeugt werden. Ebenfalls kann damit eine Fase kopiert werden (entgraten der Fläche).

Einstechfräsverfahren

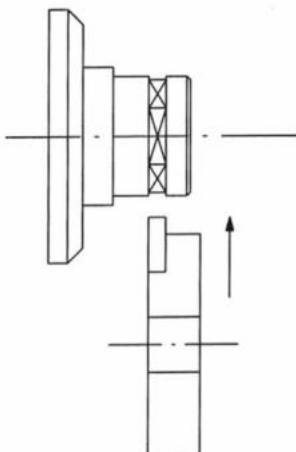

Längsfräsverfahren

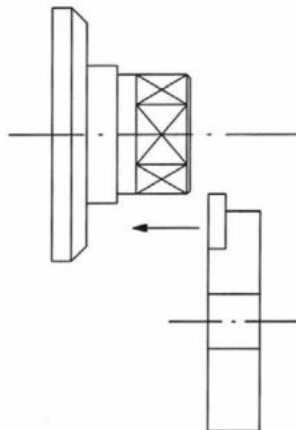

Kopieren und Längsfräsverfahren

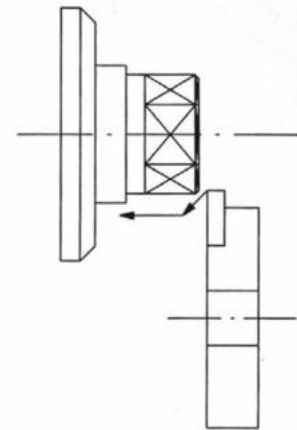

Zweikant mit 1 Schneide im Übersetzungsverhältnis von 2:1 zur Hauptspindel hergestellt.

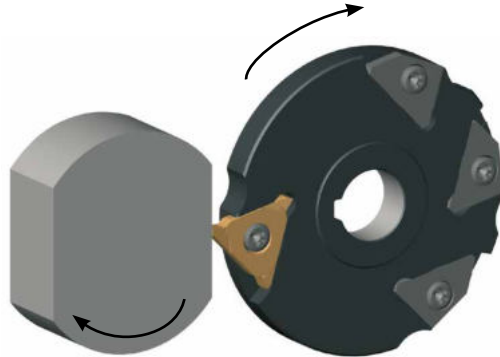

Vierkant mit 2 Schneiden im Übersetzungsverhältnis von 2:1 zur Hauptspindel hergestellt.

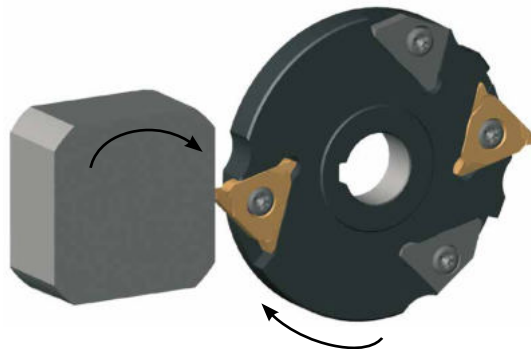

Sechskant mit 3 Schneiden im Übersetzungsverhältnis von 2:1 zur Hauptspindel hergestellt.

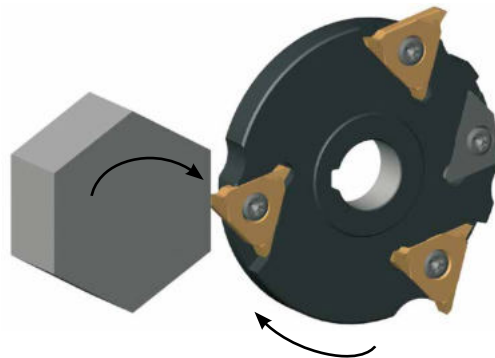

The concept of Polygon Milling

Polygon milling describes the manufacturing of flats while rotating components with polygon milling cutters on CNC lathes, Swiss Automatics lathes or Multi Spindle machines. The component (main spindle) and the milling cutter (live tool) have to run with synchronized rotations.

The operation only works in conventional milling!

The number of flats depends on the rotation ratio between component and milling cutter as well as on the number of inserts of the milling cutter.

At a revolution ratio of 2:1, the shape of the produced flats are little convex. The form error is suitable for most applications such as across-flats.

At a revolution ratio of 1:1, the shape of the produced flats are heavily convex. This shape is not suitable for across-flats.

At a revolution ratio of 3:1, the shape of the produced flats are heavily concave. This shape is as well not suitable for across-flats.

According to this, the number of flats at the component is twice the number of cutting inserts on the milling cutter.

To calculate the shape of the flats following parameter are necessary:

1. Cutting diameter of the polygon milling cutter
2. Across-flats dimension
3. Premachined diameter of the component
4. Number of flats
5. Revolution ratio of component and milling cutter

The flats can be produced by grooving or by turning. Chamfers can be produced by profiling (deburring).

Groove milling

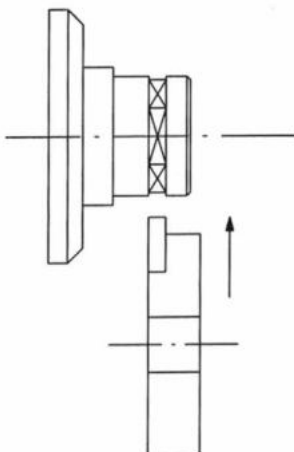

Side milling

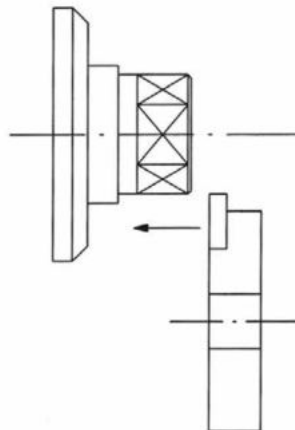

Copymilling and Side milling

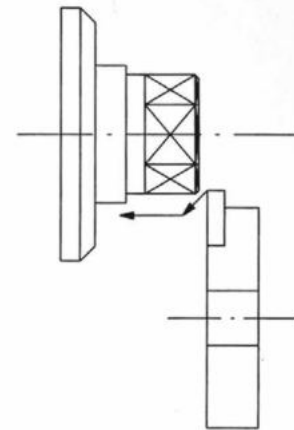

Two flats machined with 1 cutting edge. Revolution ratio 2:1 to the main spindle.

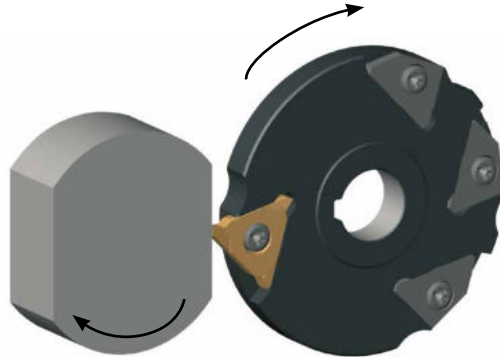

Four flats machined with 2 cutting edges. Revolution ratio 2:1 to the main spindle.

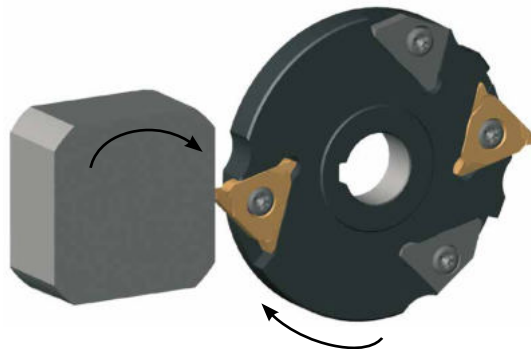

Six flats machined with 3 cutting edges. Revolution ratio 2:1 to the main spindle.

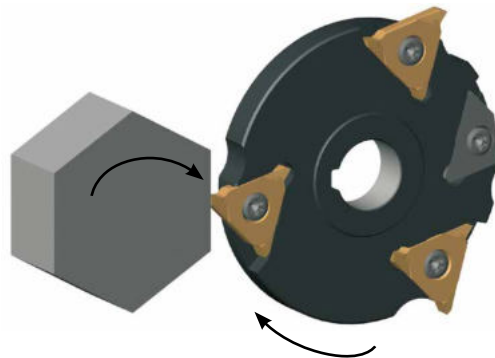

Form	Schneiden im Schlagmesser	l = WKZ:HSP	Erzeugte Flächen
	1	1 : 1	nicht empfehlenswert, stark konvex
	2 1	1 : 1 2 : 1	nicht empfehlenswert, konvex gut, leicht konvex
	3 2 1	1 : 1 1,5 : 1 3 : 1	nicht empfehlenswert, konvex empfehlenswert, konvex gut, leicht konkav
	2 1	2 : 1 4 : 1	gut, leicht konvex nicht empfehlenswert, konkav
	3 2 1	1,66 : 1 2,5 : 1 5 : 1	empfehlenswert, konvex gut, leicht konkav nicht empfehlenswert, konkav
	3 2	2 : 1 3 : 1	gut, leicht konvex nicht empfehlenswert, konkav
	4 2	2 : 1 4 : 1	gut, leicht konvex nicht empfehlenswert, konkav

Richtwerte

Werkstoff	Sorten	v_c m/min	Vorschub f_z mm	
			Längsfräsverfahren	Einstechfräsverfahren
Al	TI25, MG12	500 - 1000	0,10 - 0,20	0,05 - 0,10
Ms58	TI25, MG12	500 - 1000	0,10 - 0,20	0,05 - 0,10
9SMnPb28	TH35, TI25, AS45	200 - 500	0,08 - 0,15	0,04 - 0,08
16MnCr5/C45	TH35, TI25, AS45	150 - 250	0,05 - 0,10	0,03 - 0,05

Vorschubswerte sind nur beim Längsfräsverfahren gültig!

Beim Einstechfräsverfahren muss der Vorschub pro Zahn, je nach Schneidbreite der Wendeschneidplatte, um 30 - 50 % reduziert werden!

Beispiel:
Längsfräsverfahren
Werkstoff: Stahl

Schlagmesser \varnothing 90 mm
SW 24 mm (\varnothing 27,7 mm)

$v_{c\text{eff}} = 448,00$ m/min

$f_z = 0,08$ mm

3 Schneiden, $l = 2:1$

Länge des Sechskants: 12 mm

Bearbeitungszeit: $\sim 2,19$ s

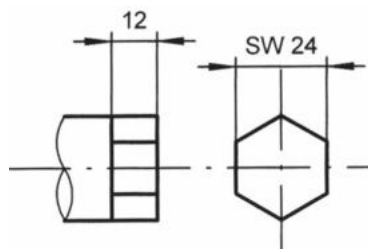

Werkzeug:

$n_{WZ} = 1372,00$ mm⁻¹

$v_{cWZ} = 388,25$ m/min

Werkstück:

$n_{WS} = 686,00$ mm⁻¹

$v_{cWS} = 59,75$ m/min

Form	No. of inserts on the cutter	Ratio = Tool:Spindel	Flats
	1	1 : 1	not suitable, heavily convex
	2 1	1 : 1 2 : 1	not suitable, convex very suitable, little convex
	3 2 1	1 : 1 1,5 : 1 3 : 1	not suitable, convex suitable, convex very suitable, little concave
	2 1	2 : 1 4 : 1	very suitable, little convex not suitable, concave
	3 2 1	1,66 : 1 2,5 : 1 5 : 1	suitable, convex very suitable, little concave not suitable, concave
	3 2	2 : 1 3 : 1	very suitable, little convex not suitable, concave
	4 2	2 : 1 4 : 1	very suitable, little convex not suitable, concave

Cutting data

Material	Grades	v_c m/min	Feed rate f_z mm	
			Side milling	Groove milling
Al	TI25, MG12	500 - 1000	0,10 - 0,20	0,05 - 0,10
Ms58	TI25, MG12	500 - 1000	0,10 - 0,20	0,05 - 0,10
9SMnPb28	TH35, TI25, AS45	200 - 500	0,08 - 0,15	0,04 - 0,08
16MnCr5/C45	TH35, TI25, AS45	150 - 250	0,05 - 0,10	0,03 - 0,05

Feed rate values only valid for side milling process!

At groove milling process the feed rate has to be reduced by 30 - 50 %, depending on the insert width!

Example:
Side milling
Material: Steel

Cutter \varnothing 90 mm
SW 24 mm (\varnothing 27,7 mm)
 $v_{c\text{eff}} = 448,00$ m/min
 $f_z = 0,08$ mm
3 Cutting edges, $l = 2:1$
Flat length: 12 mm
Cycle time: $\sim 2,19$ s

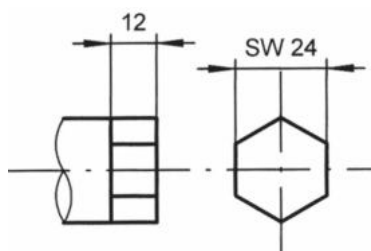

Tool:
 $n_{WZ} = 1372,00$ mm⁻¹
 $v_{cWZ} = 388,25$ m/min

Workpiece:
 $n_{WS} = 686,00$ mm⁻¹
 $v_{cWS} = 59,75$ m/min

Übersicht Maschinenhersteller

Overview Machine manufacturer



Hersteller Machine manufacturer	Maschine Machine	Schlagmesser Cutter	Wendeschneidplatten Indexable inserts	Z	n _{max} Fräser n _{max} Milling cutter
Gildemeister	GD32	L381.G070.15.04	L314.MK50.20 TN35	2/3	13.000 min-1
Gildemeister	GLD25	L381.G070.15.04	L314.MK50.20 TN35	2/3	13.000 min-1
Gildemeister	GM20-6	L381.G086.25.04	L314.MK50.20 TN35	2/3	11.000 min-1
Gildemeister	GM26-6	L381.G080.16.04	L314.MK40.20 TN35	2/3	12.000 min-1
Gildemeister	GM35-6	L381.G098.26.04	L314.MK50.20 TN35	2/3	10.000 min-1
Gildemeister	GM35-8	L381.G086.25.04	L314.MK50.20 TN35	2/3	11.000 min-1
Gildemeister	GM35-8	L381.G098.26.04	L314.MK50.20 TN35	2/3	10.000 min-1
Gildemeister	GM42-6	L381.G098.26.04	L314.MK50.20 TN35	2/3	10.000 min-1
Gildemeister	GMC35	L381.G086.25.04	L314.MK50.20 TN35	2/3	11.000 min-1
Gildemeister	GMC35	L381.G098.26.04	L314.MK50.20 TN35	2/3	10.000 min-1
Gildemeister	SPRINT20/32	L381.G080.16.04	L314.MK40.20 TN35	2/3	12.000 min-1
Gildemeister	SPRINT32L	L381.G090.22.04	L314.MK50.20 TN35	2/3	13.000 min-1
Gildemeister	SPRINT44L	L381.G090.22.04	L314.MK50.20 TN35	2/3	13.000 min-1
INDEX	ABC	R381.X090.27.04	R314.MK50.20 TN35	2/3	11.000 min-1
INDEX	ABC	L381.X090.27.04	L314.MK50.20 TN35	2/3	11.000 min-1
INDEX	MS25	L381.X073.16.04	N314.MK40.20 TN35	2/3	13.000 min-1
NAKAMURA	WT250	L381.N090.16.04	N314.MK40.20 TN35	2/3	11.000 min-1
Alfred H. Schütte	AF26	L381.S098.30.03	L314.MK70.M0 TN35	3	15.000 min-1*
Alfred H. Schütte	AF26	L381.S098.30.02	L314.MK70.M0 TN35	2	15.000 min-1*
Alfred H. Schütte	AF32	L381.S098.30.03	L314.MK70.M0 TN35	3	15.000 min-1*
Alfred H. Schütte	AF32	L381.S098.30.02	L314.MK70.M0 TN35	2	15.000 min-1*
Alfred H. Schütte	AF42	L381.S118.30.03	L314.MK70.M0 TN35	3	12.000 min-1*
Alfred H. Schütte	AF42	L381.S118.30.02	L314.MK70.M0 TN35	2	12.000 min-1*
Alfred H. Schütte	AG18	L381.S078.30.03	L314.MK70.M0 TN35	3	20.000 min-1*
Alfred H. Schütte	AG18	L381.S078.30.02	L314.MK70.M0 TN35	2	20.000 min-1*
Alfred H. Schütte	SE18	L381.S098.30.03	L314.MK70.M0 TN35	3	15.000 min-1*
Alfred H. Schütte	SE18	L381.S098.30.02	L314.MK70.M0 TN35	2	15.000 min-1*
Alfred H. Schütte	SF20	L381.S098.30.03	L314.MK70.M0 TN35	3	15.000 min-1*
Alfred H. Schütte	SF20	L381.S098.30.02	L314.MK70.M0 TN35	2	15.000 min-1*
Alfred H. Schütte	SF26L	L381.S098.30.03	L314.MK70.M0 TN35	3	15.000 min-1*
Alfred H. Schütte	SF26L	L381.S098.30.02	L314.MK70.M0 TN35	2	15.000 min-1*
Alfred H. Schütte	SF26	L381.S098.30.03	L314.MK70.M0 TN35	3	15.000 min-1*
Alfred H. Schütte	SF26S	L381.S098.30.03	L314.MK70.M0 TN35	3	15.000 min-1*
Alfred H. Schütte	SF26S	L381.S098.30.02	L314.MK70.M0 TN35	2	15.000 min-1*
Alfred H. Schütte	SF26	L381.S098.30.02	L314.MK70.M0 TN35	2	15.000 min-1*
Alfred H. Schütte	SF32	L381.S118.30.03	L314.MK70.M0 TN35	3	12.000 min-1*
Alfred H. Schütte	SF32	L381.S118.30.02	L314.MK70.M0 TN35	2	12.000 min-1*
Alfred H. Schütte	SF42	L381.S118.30.03	L314.MK70.M0 TN35	3	12.000 min-1*
Alfred H. Schütte	SF42	L381.S118.30.02	L314.MK70.M0 TN35	2	12.000 min-1*
Alfred H. Schütte	SF51	L381.S118.30.03	L314.MK70.M0 TN35	3	12.000 min-1*
Alfred H. Schütte	SF51	L381.S118.30.02	L314.MK70.M0 TN35	2	12.000 min-1*
Alfred H. Schütte	SF67	L381.S118.30.03	L314.MK70.M0 TN35	3	12.000 min-1*
Alfred H. Schütte	SF67	L381.S118.30.02	L314.MK70.M0 TN35	2	12.000 min-1*

Übersicht Maschinenhersteller

Overview Machine manufacturer



Hersteller Machine manufacturer	Maschine Machine	Schlagmesser Cutter	Wendeschneidplatten Indexable inserts	Z	n _{max} Fräser n _{max} Milling cutter
Alfred H. Schütte	SG18	L381.S078.30.03	L314.MK70.M0 TN35	3	20.000 min-1*
Alfred H. Schütte	SG18	L381.S078.30.02	L314.MK70.M0 TN35	2	20.000 min-1*
Alfred H. Schütte	SG20	L381.S078.30.03	L314.MK70.M0 TN35	3	20.000 min-1*
Alfred H. Schütte	SG20	L381.S078.30.02	L314.MK70.M0 TN35	2	20.000 min-1*
Star	SR-20J	L381.A060.12.04	314.MK40.20	1/3	12.000 min-1
TORNOS	Deco7/10	R/LM275.D040.10.04	R/LS275.MK13.M0 TN35	2/3	15.000 min-1
TORNOS	Deco13	L381.D080.16.04	N314.MK40.20 TN35	2/3	12.000 min-1
TORNOS	Deco20	L381.D080.16.04	N314.MK40.20 TN35	2/3	12.000 min-1
TORNOS	Deco26	L381.D080.16.04	N314.MK40.20 TN35	2/3	12.000 min-1
TORNOS	Deco2000	L381.D080.16.04	N314.MK40.20 TN35	2/3	12.000 min-1
TORNOS	Multi Deco	L381.D086.25.04	L314.MK50.20 TN35	3	15.000 min-1
TRAUB	TNL12-7	RM275.T064.33.03	RS275.MK13.M0TN35	3	13.000 min-1
TRAUB	TNL12-7	L381.T069.12.04	N314.MK40.20 TN35	2/3	13.000 min-1
TRAUB	TNL26	L381.T069.12.04	N314.MK40.20 TN35	2/3	13.000 min-1
TRAUB	TNK36	L381.T069.12.04	N314.MK40.20 TN35	2/3	13.000 min-1

Mehrkantschlagmesser für weitere Maschinen auf Anfrage.
Polygon cutter for further machines upon request.

* geschlossener Plattensitz
* reinforced pocket



System/System

Seite/Page

DA

466

DAH

492

Schaftfräser
End Mill
DAM31/DAM32/DAM62

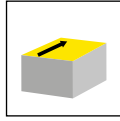

Seite/Page
468-472

Aufsteckfräser
Arbour Mounted Cutter
DAM32/DAM62

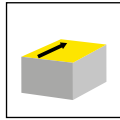

Seite/Page
473-474

Einschraubfräser
Screw-in cutter
DAM31/DAM32/DAM62

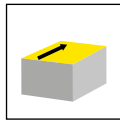

Seite/Page
475, 477

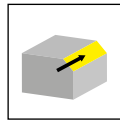

Seite/Page
476

Aufnahme
Adaptor
MD

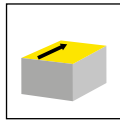

Seite/Page
478-479

Reduzierstück
Reducer
MD

Seite/Page
480

Verlängerung
Extension
MD

Seite/Page
481

Wendeschneidplatte
Indexable insert
DA31/DA32/DA62/
SDA62

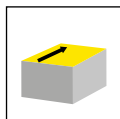

Seite/Page
482-483, 486-487

Schneidplatte
Insert
DA32

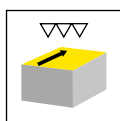

Seite/Page
484-485

DA

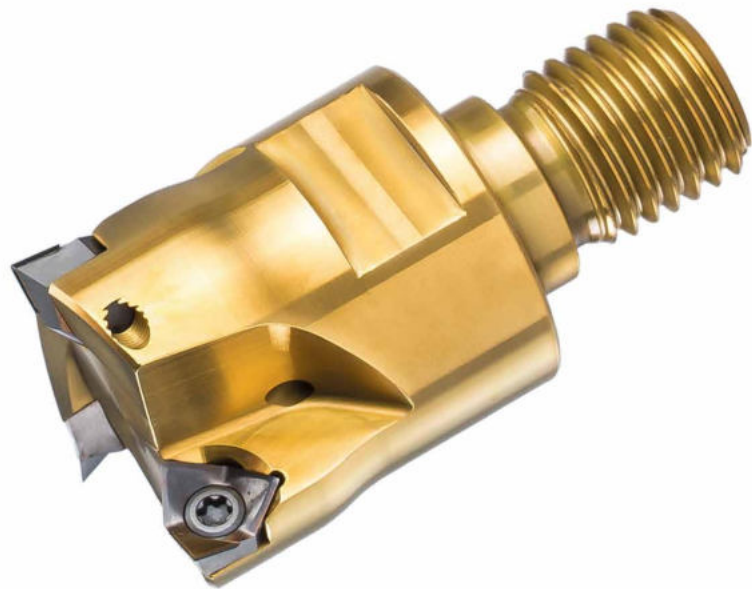

System DA

- Fräterschäfte
- Aufsteckfräser
- Einschraubfräser
- Wendeschneidplatten

System DA

- Milling shanks
- Arbor Mounted Cutter
- Screw-in Cutter
- Indexable Inserts

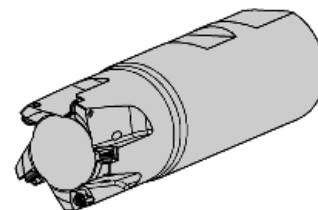
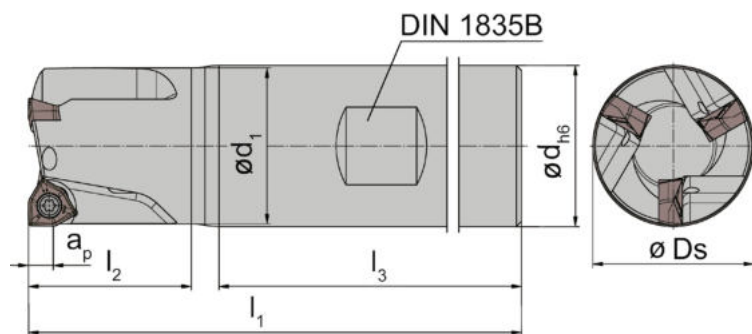
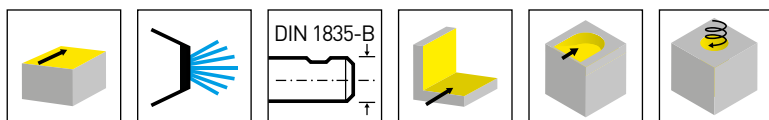

Bestellnummer Part number	Z	Ds	d	l_1	l_2	d_1	l_3	a_p	HWS
DAM31.016.D163.02B	2	16	16	79	17	15	54	3	DA3116
DAM31.020.D204.03B	3	20	20	86	21	19	59	3	DA3120
DAM31.025.D255.04B	4	25	25	97	27	24	64	3	DA3125
DAM31.032.D326.05B	5	32	32	106	32	31	68	3	DA3132
DAM32.020.D205.02B	2	20	20	87	22	19	19	4,8	DA3220
DAM32.025.D256.03B	3	25	25	102	32	24	64	4,8	DA3225
DAM32.032.D327.03B	3	32	32	106	32	31	68	4,8	DA3232

ab \varnothing 25 mm 2 Spannflächen
from \varnothing 25 mm 2 clamping flats

Ersatzteile

Spare Parts

Schaftfräser End Mill	Spannschraube Clamping Screw	TORX PLUS®-Schlüssel TORX PLUS® Wrench
DAM31.016.D163.02B	030.2541.T8P	T8PL
DAM31.020.D204.03B	030.2547.T8P	T8PL
DAM31.025.D255.04B	030.2553.T8P	T8PL
DAM31.032.D326.05B	030.2557.T8P	T8PL
DAM32.020.D205.02B	030.3562.T10P	T10PL
DAM32.025.D256.03B	030.3569.T10P	T10PL
DAM32.032.D327.03B	030.3576.T10P	T10PL

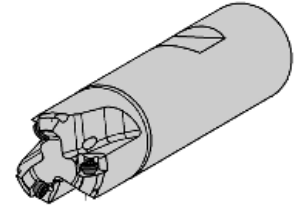
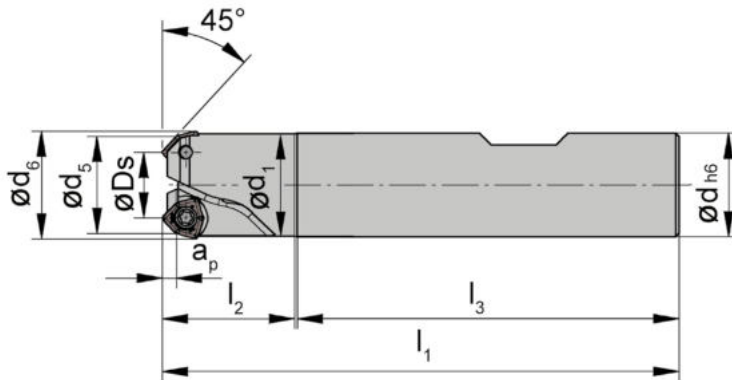
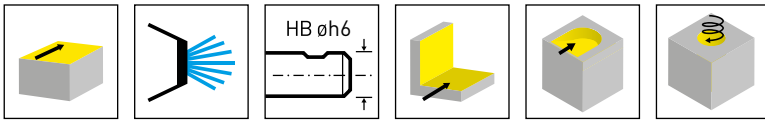

Bestellnummer Part number	Z	Ds	d	l ₁	l ₂	d ₁	l ₃	a _p	d ₆	d ₅	HWS
DAM31.411.D163.02B	2	10,4	16	80	20	15,8	59	2	16,9	15	DA3116
DAM31.414.D204.03B	3	14,4	20	87	23	18,8	62	2	20,9	19	DA3120

Ersatzteile
Spare Parts

Schaftfräser End Mill	Spannschraube Clamping Screw	TORX PLUS®-Schlüssel TORX PLUS® Wrench
DAM31.411.D163.02B	030.2541.T8P	T8PL
DAM31.414.D204.03B	030.2547.T8P	T8PL

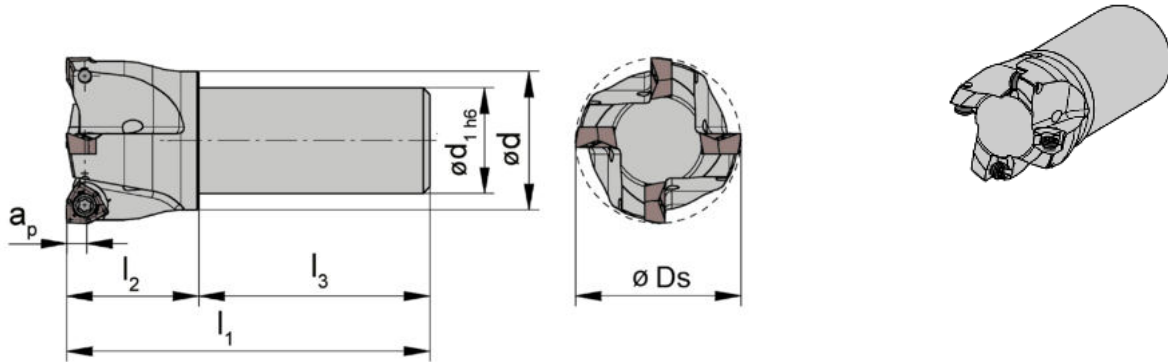
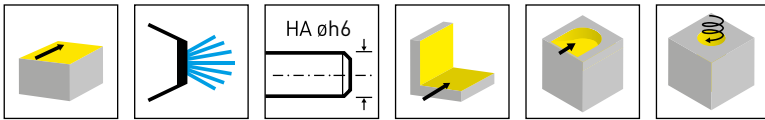

Bestellnummer Part number	Z	Ds	d	l ₁	l ₂	d ₁	l ₃	a _p	HWS
DAM31.020.D160.03A	3	20	19	52	17	16	35	3	DA3120
DAM31.025.D161.04A	4	25	24	55	20	16	35	3	DA3125
DAM31.032.D162.05A	5	32	31	60	25	16	35	3	DA3132
DAM31.032.D202.05A	5	32	31	60	25	20	35	3	DA3132

Ersatzteile

Spare Parts

Schaftfräser End Mill	Spannschraube Clamping Screw	TORX PLUS®-Schlüssel TORX PLUS® Wrench
DAM31.020.D160.03A	030.2547.T8P	T8PL
DAM31.025.D161.04A	030.2553.T8P	T8PL
DAM31.032....	030.2557.T8P	T8PL

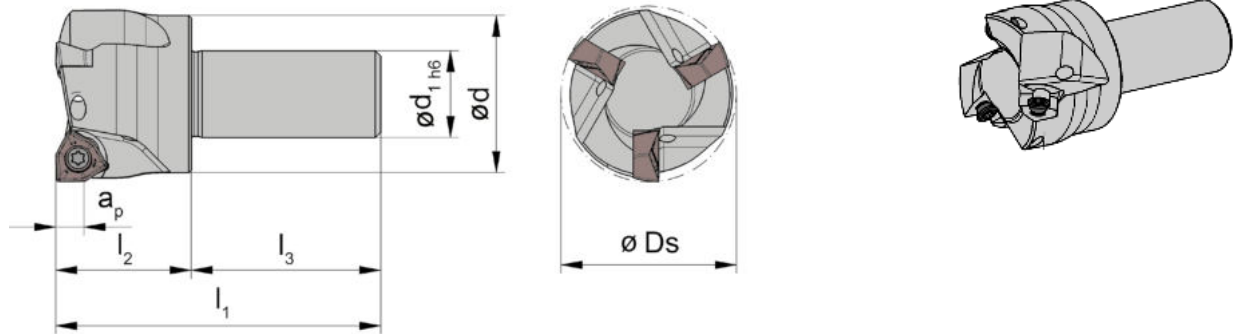
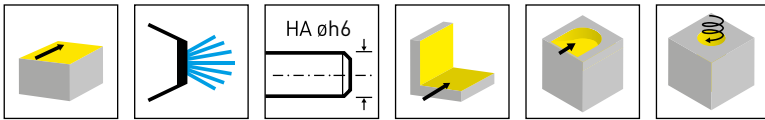

Bestellnummer Part number	Z	Ds	d	l ₁	l ₂	d ₁	l ₃	a _p	HWS
DAM32.020.D160.02A	2	20	19	52	17	16	35	4,5	DA3220
DAM32.025.D161.03A	3	25	24	55	20	16	35	4,5	DA3225
DAM32.032.D162.03A	3	32	31	60	25	16	35	4,5	DA3232

Ersatzteile

Spare Parts

Schaftfräser End Mill	Spannschraube Clamping Screw	TORX PLUS®-Schlüssel TORX PLUS® Wrench
DAM32.020.D160.02A	030.3562.T10P	T10PL
DAM32.025.D161.03A	030.3569.T10P	T10PL
DAM32.032.D162.03A	030.3576.T10P	T10PL



Abbildung = rechtsschneidend
Picture = right hand cutting version

Bestellnummer Part number	Z	Ds	d	l_1	l_2	d_1	l_3	a_p	HWS
DAM62.020.D20.4.02B	2	20	20	85	33	19	50	4,5	DA6200
DAM62.025.D25.5.03B	3	25	25	95	37	24	56	4,5	DA6200
DAM62.032.D32.6.04B	4	32	32	111	47	31	60	4,5	DA6200

L

Ersatzteile

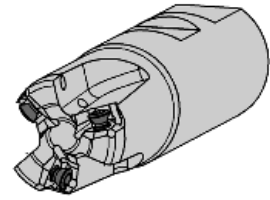
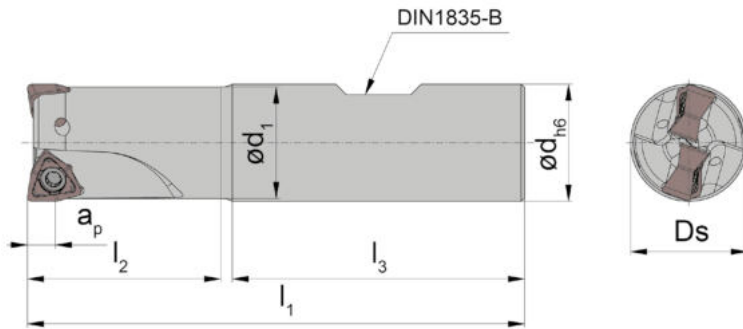
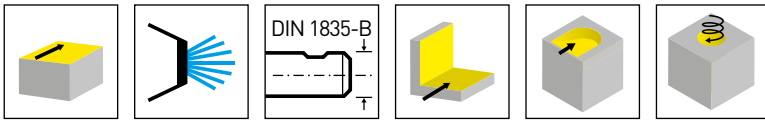
Spare Parts

Schaftfräser End Mill	Spannschraube Clamping Screw	TORX PLUS®-Schlüssel TORX PLUS® Wrench
DAM62...	030.3070.T10P	T10PL



Abbildung = rechtsschneidend
Picture = right hand cutting version

Bestellnummer Part number	Z	Ds	ap	h ₂	h	d _s	d ₂	l ₂	b	C	d _k	HWS
DAM32.040.A1635.04	4	40	4,8	34,4	35	16	16	22	8,4	5,6	33	DA3232
DAM32.050.A2240.05	5	50	4,8	39,4	40	19,5	22	24	10,4	6,3	41	DA3232
DAM32.063.A2745.06	6	63	4,8	44,4	45	21,5	27	27	12,4	7	49	DA3232

Ersatzteile
Spare Parts

Aufsteckfräser Arbour Mounted Cutter	Spannschraube Clamping Screw	TORX PLUS®-Schlüssel TORX PLUS® Wrench
DAM32...	030.3576.T10P	T10PL

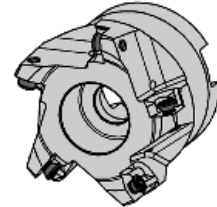
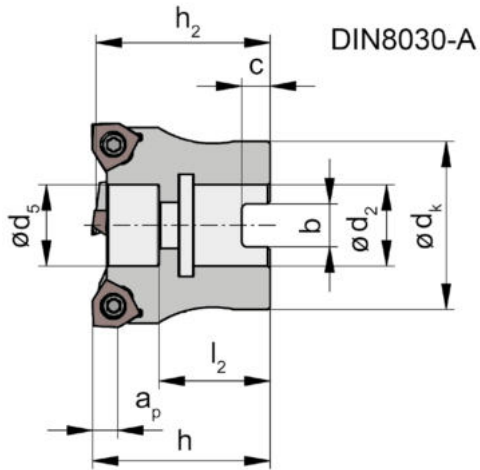
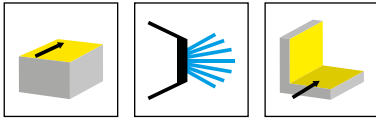

Abbildung = rechtsschneidend
Picture = right hand cutting version

Bestellnummer Part number	Z	Ds	ap	h ₂	h	d ₅	d ₂	l ₂	b	C	d _k	HWS
DAM62.0040.A16.05	5	40	4,5	34	35	16	16	21,5	8,4	5,6	33	DA6200
DAM62.0050.A22.06	6	50	4,5	39	40	19,5	22	23,5	10,4	6,3	41	DA6200
DAM62.0063.A22.08	8	63	4,5	39	40	19,5	22	24	10,4	6,3	49	DA6200
DAM62.0080.A27.10	10	80	4,5	49	50	21,5	27	27,5	12,4	7	59	DA6200

Ersatzteile
Spare Parts

Aufsteckfräser Arbour Mounted Cutter	Spannschraube Clamping Screw	TORX PLUS®-Schlüssel TORX PLUS® Wrench
DAM62...	030.3070.T10P	T10PL

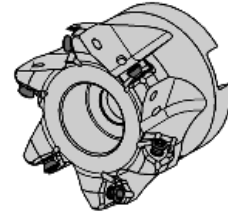
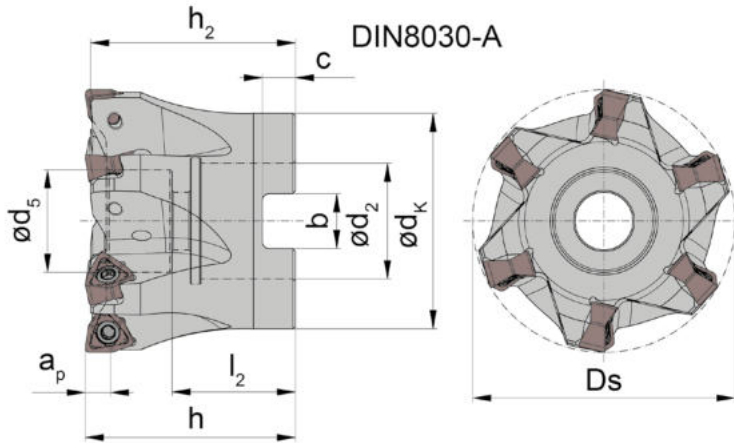
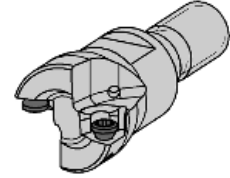
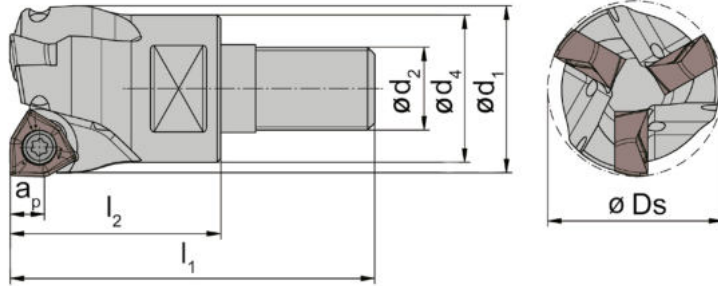
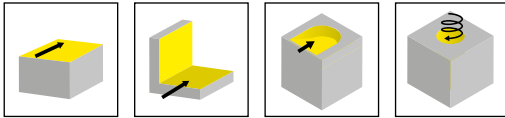

Bestellnummer Part number	Z	Ds	l ₁	l ₂	d ₁	a _p	d ₂	d ₄	SW	HWS	HMS
DAM31.016.M083.02B	2	16	38	20	15	3	M8	13	10	DA3116	08001
DAM31.020.M104.03B	3	20	45	25	19	3	M10	18	15	DA3120	10001
DAM31.025.M125.04B	4	25	52	30	24	3	M12	21	17	DA3125	12001
DAM31.032.M166.05B	5	32	58	35	31	3	M16	29	24	DA3132	16001
DAM32.020.M104.02B	2	20	45	25	19	4,8	M10	18	15	DA3220	10001
DAM32.025.M125.03B	3	25	52	30	24	4,8	M12	21	17	DA3225	12001
DAM32.032.M166.03B	3	32	58	35	31	4,8	M16	29	24	DA3232	16001

Ersatzteile

Spare Parts

Einschraubfräser Screw-in cutter	Spannschraube Clamping Screw	TORX PLUS®-Schlüssel TORX PLUS® Wrench
DAM31.016.M083.02B	030.2541.T8P	T8PL
DAM31.020.M104.03B	030.2547.T8P	T8PL
DAM31.025.M125.04B	030.2553.T8P	T8PL
DAM31.032.M166.05B	030.2557.T8P	T8PL
DAM32.020.M104.02B	030.3562.T10P	T10PL
DAM32.025.M125.03B	030.3569.T10P	T10PL
DAM32.032.M166.03B	030.3576.T10P	T10PL

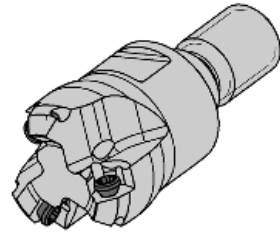
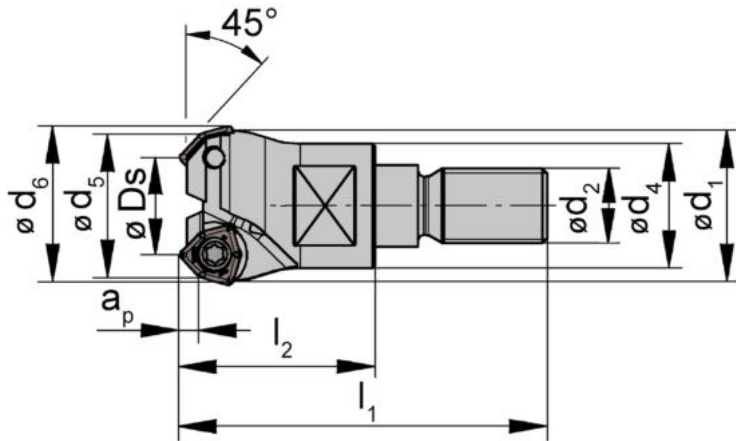
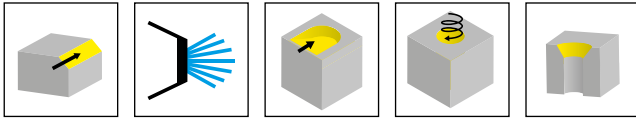

Bestellnummer Part number	Z	Ds	l ₁	l ₂	d ₁	a _p	d ₂	d ₄	d ₅	d ₆	SW	HWS	HMS
DAM31.411.M083.02B	2	10,5	38	20	15,8	2	M8	13	15	16,9	10	DA3116	08001
DAM31.414.M104.03B	3	14,4	45	25	19,8	2	M10	18	19	20,9	15	DA3120	10001
DAM32.417.M125.03B	3	17,6	52	30	24,8	3,2	M12	21	24	28,3	17	DA3225	12001

Ersatzteile

Spare Parts

Einschraubfräser Screw-in cutter	Spannschraube Clamping Screw	TORX PLUS®-Schlüssel TORX PLUS® Wrench
DAM31.411.M083.02B	030.2541.T8P	T8PL
DAM31.414.M104.03B	030.2547.T8P	T8PL
DAM32.417.M125.03B	030.3569.T10P	T10PL



Abbildung = rechtsschneidend
Picture = right hand cutting version

Bestellnummer Part number	Z	Ds	l ₁	l ₂	d ₁	a _p	d ₂	d ₄	SW	HWS	HMS
DAM62.025.M12.5.03	3	25	57	35	24	4,5	M12	21	17	DA6200	12001
DAM62.032.M16.6.04	4	32	66	43	31	4,5	M16	29	24	DA6200	16001

Ersatzteile
Spare Parts

Einschraubfräser Screw-in cutter	Spannschraube Clamping Screw	TORX PLUS®-Schlüssel TORX PLUS® Wrench
DAM62...	030.3070.T10P	T10PL

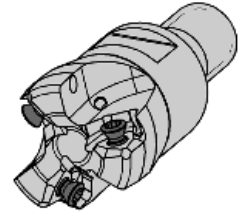
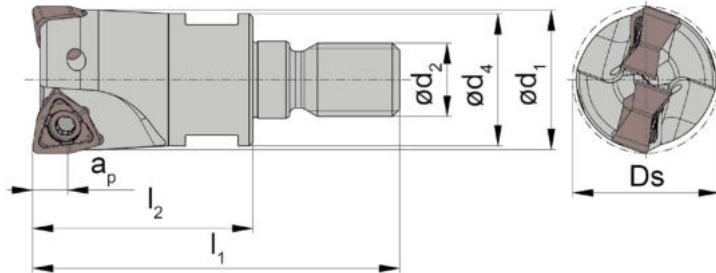
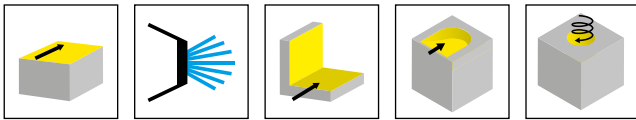
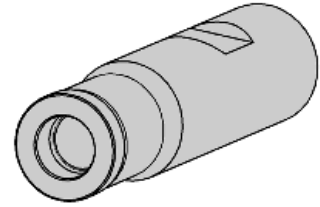
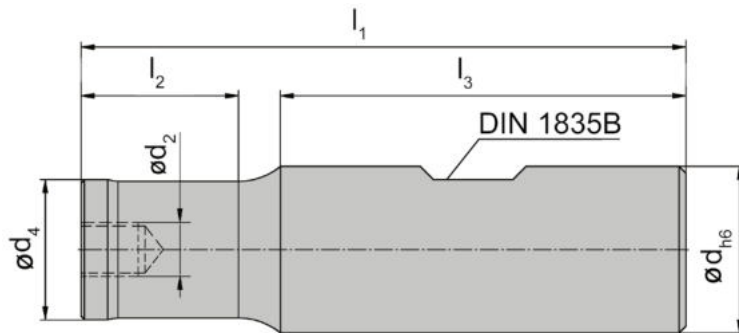
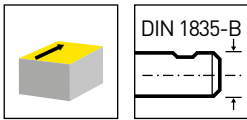

Bestellnummer Part number	l_1	l_2	l_3	d	d_4	d_2
MD13.02.00.D16B	73	14	53	16	13	M8
MD18.04.00.D20B	80	20	55	20	18	M10
MD21.06.00.D25B	91	23	61	25	21	M12
MD29.08.00.D32B	100	29	65	32	29	M16

ab \varnothing 25 mm 2 Spannflächen
from \varnothing 25 mm 2 clamping flats

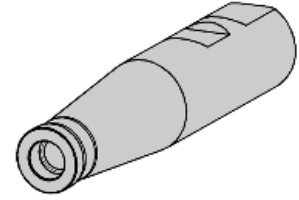
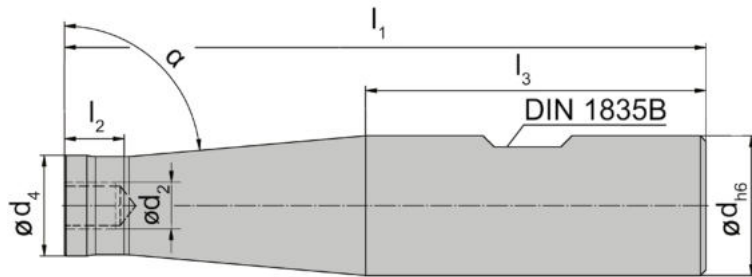
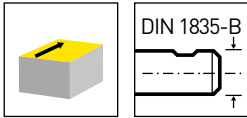

Bestellnummer Part number	l_1	l_2	l_3	d	d_4	d_2	α
MD13.02.85.D20B	105	7	55	20	13	M8	85°
MD18.04.85.D25B	115	10	61	25	18	M10	85°
MD21.06.85.D32B	140	8	65	32	21	M12	85°
MD29.08.85.D40B	150	8	75	40	29	M16	85°

ab \varnothing 25 mm 2 Spannflächen
from \varnothing 25 mm 2 clamping flats

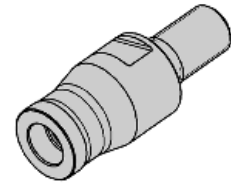
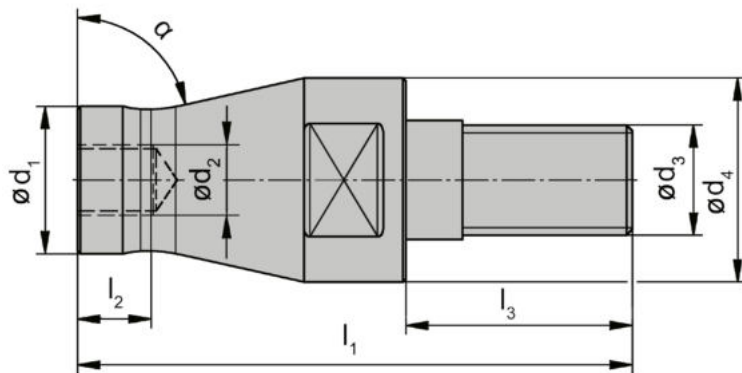

Bestellnummer Part number	l_1	l_2	l_3	d_1	d_2	d_3	d_4	SW	α
MD18.02.77.M10	49	6	20	13	M8	M10	18	15	77,5°
MD21.04.77.M12	56	10	22	18	M10	M12	21	17	77,5°
MD29.06.77.M16	52	6	23	21	M12	M16	29	24	77,5°

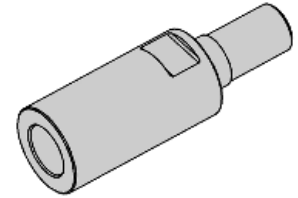
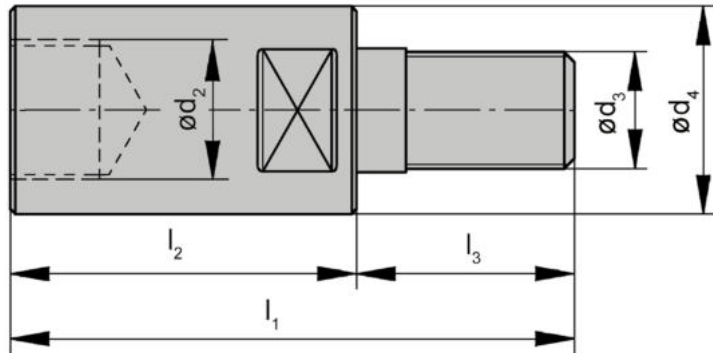

Bestellnummer Part number	l_1	l_2	l_3	d_2	d_3	d_4	SW
MD13.02.00.M08	48	30	18	M8	M8	13	10
MD18.04.00.M10	55	35	20	M10	M10	18	15
MD21.06.00.M12	57	35	22	M12	M12	21	17
MD29.08.00.M16	58	35	23	M16	M16	29	24

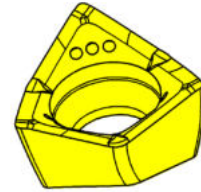
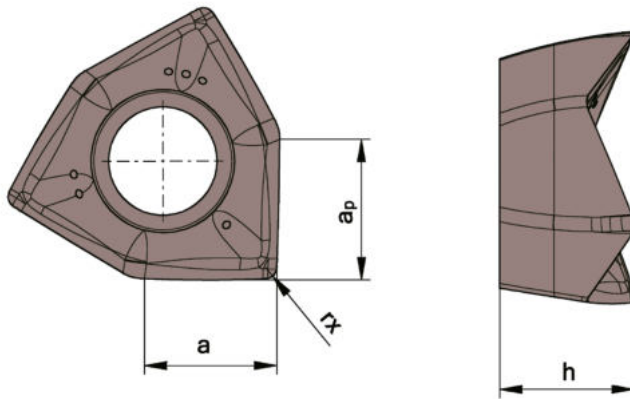
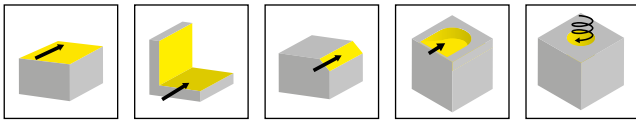

HM-Sorten
Carbide grades

▲ ab Lager
on stock

△ 4 Wochen
4 weeks

Bestellnummer Part number	Ds	a _p	a	h	r _x	HIS	SA4B	TA45
DA31.016.A.00	16	3	3	3,1	-	DA3116	▲	▲
DA31.016.A.02	16	3	3	3,1	0,2	DA3116	▲	▲
DA31.016.A.04	16	3	3	3,1	0,4	DA3116	▲	▲
DA31.020.A.00	20	3	3	3,1	-	DA3120	△	▲
DA31.020.A.02	20	3	3	3,1	0,2	DA3120	▲	▲
DA31.020.A.04	20	3	3	3,1	0,4	DA3120	▲	▲
DA31.025.A.00	25	3	3	3,1	-	DA3125	▲	▲
DA31.025.A.02	25	3	3	3,1	0,2	DA3125	▲	▲
DA31.025.A.04	25	3	3	3,1	0,4	DA3125	▲	△
DA31.032.A.00	32	3	3	3,1	-	DA3132	▲	▲
DA31.032.A.02	32	3	3	3,1	0,2	DA3132	▲	▲
DA31.032.A.04	32	3	3	3,1	0,4	DA3132	▲	▲

HM-Sorte TA45 bevorzugt für leichte Zerspanaufgaben, Aluminium und Schlichten.

HM-Sorte SA4B bevorzugt für mittlere und schwere Zerspanaufgaben.
Carbide grade TA45 preferred for easy to machine materials, aluminium and finishing.
Carbide grade SA4B preferred for middle and difficult to machine materials.

P	●	●
M	●	●
K	●	●
N	●	●
S	-	●
H	-	-

Wendeschneidplatte Indexable insert

DA32

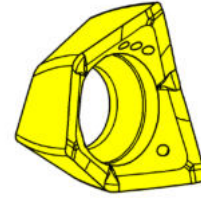
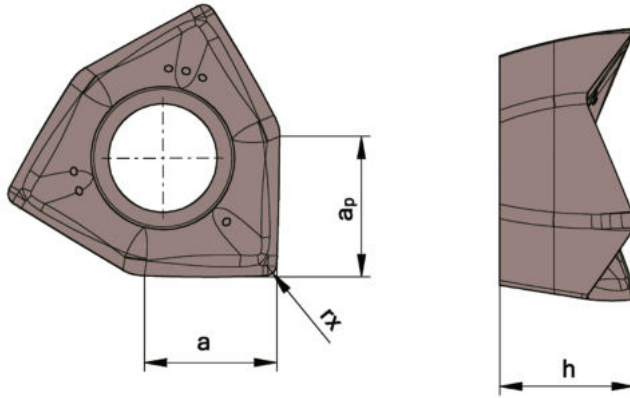
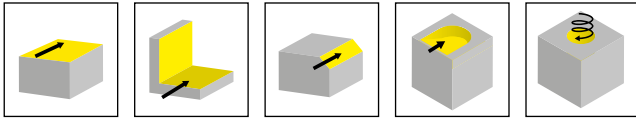

HM-Sorten
Carbide grades

▲ ab Lager
on stock

△ 4 Wochen
4 weeks

Bestellnummer Part number	Ds	a _p	a	h	r _x	HIS	SA4B	TA45
DA32.020.A.00	20	4,8	4,6	4,7	-	DA3220	△	△
DA32.020.A.02	20	4,8	4,6	4,7	0,2	DA3220	▲	△
DA32.020.A.04	20	4,8	4,6	4,7	0,4	DA3220	▲	
DA32.020.A.08	20	4,8	4,6	4,7	0,8	DA3220	▲	▲
DA32.020.A.10	20	4,8	4,6	4,7	1	DA3220	▲	▲
DA32.025.A.00	25	4,8	4,6	4,7	-	DA3225	△	△
DA32.025.A.02	25	4,8	4,6	4,7	0,2	DA3225	▲	△
DA32.025.A.04	25	4,8	4,6	4,7	0,4	DA3225	▲	▲
DA32.025.A.08	25	4,8	4,6	4,7	0,8	DA3225	▲	▲
DA32.025.A.10	25	4,8	4,6	4,7	1	DA3225	△	▲
DA32.032.A.00	32	4,8	4,6	4,7	-	DA3232	△	△
DA32.032.A.02	32	4,8	4,6	4,7	0,2	DA3232	▲	▲
DA32.032.A.04	32	4,8	4,6	4,7	0,4	DA3232	▲	▲
DA32.032.A.08	32	4,8	4,6	4,7	0,8	DA3232	▲	▲
DA32.032.A.10	32	4,8	4,6	4,7	1	DA3232	▲	▲

HM-Sorte TA45 bevorzugt für leichte Zerspanaufgaben, Aluminium und Schlichten.

HM-Sorte SA4B bevorzugt für mittlere und schwere Zerspanaufgaben.

Carbide grade TA45 preferred for easy to machine materials, aluminium and finishing.

Carbide grade SA4B preferred for middle and difficult to machine materials.

P	●	●
M	●	●
K	●	●
N	●	●
S	-	●
H	-	-

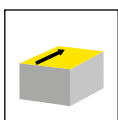
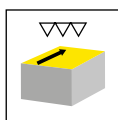

CVD-D

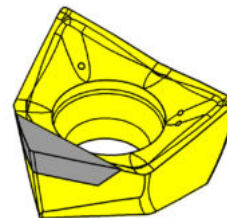
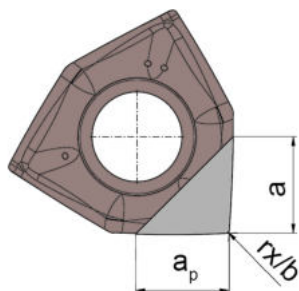
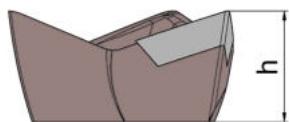

HM-Sorten
Carbide grades

▲ ab Lager
on stock

Δ 4 Wochen
4 weeks

Bestellnummer Part number	D _s	a _p	a	h	r _x	b x 45°	HIS	HD05
DA32.020.25.02.C	20	3,8	3,5	4,7	0,2	-	DA3220	▲
DA32.020.25.X2.C	20	3,8	3,5	4,7	-	0,2	DA3220	Δ
DA32.025.25.02.C	25	3,8	3,5	4,7	0,2	-	DA3225	▲
DA32.025.25.X2.C	25	3,8	3,5	4,7	-	0,2	DA3225	Δ
DA32.032.25.02.C	32	3,8	3,5	4,7	0,2	-	DA3232	▲
DA32.032.25.X2.C	32	3,8	3,5	4,7	-	0,2	DA3232	▲
								P -
								M -
								K -
								N ●
								S -
								H -

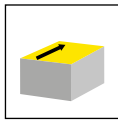
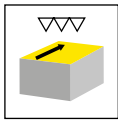

PKD
PCD

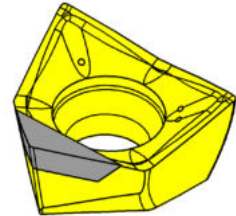
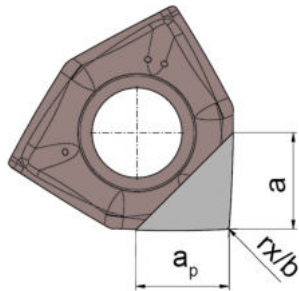
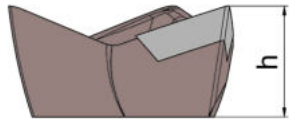

HM-Sorten
Carbide grades

▲ ab Lager
on stock

△ 4 Wochen
4 weeks

Bestellnummer Part number	Ds	a _p	a	h	r _x	HIS	PD75
DA32.020.25.02.P	20	3,8	3,5	4,7	0,2	DA3220	▲
DA32.025.25.02.P	25	3,8	3,5	4,7	0,2	DA3225	▲
DA32.032.25.02.P	32	3,8	3,5	4,7	0,2	DA3232	▲
							P -
							M -
							K -
							N ●
							S -
							H -

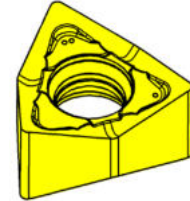
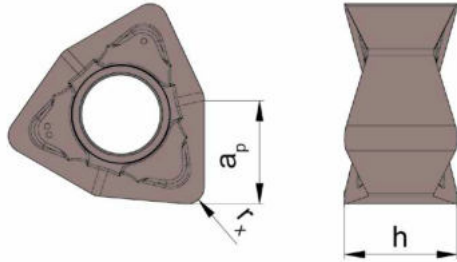
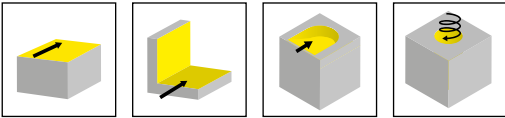

▲ ab Lager
on stock

△ 4 Wochen
4 weeks

HM-Sorten
Carbide grades

Bestellnummer Part number	a_p	h	r_x	HIS	SA4B	SD6A
DA62.0400.A.04	4,5	5,2	0,4	DA6200	▲	▲
DA62.0400.A.08	4,5	5,16	0,8	DA6200	▲	▲
					P ●	○
					M ●	-
					K ●	●
					N ●	-
					S -	-
					H -	-

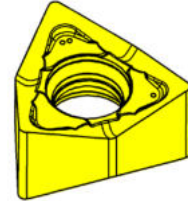
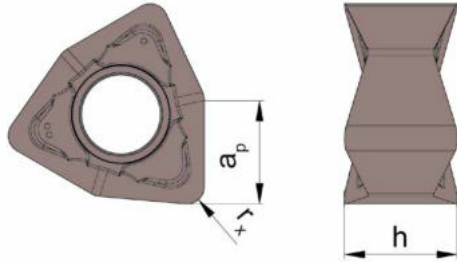
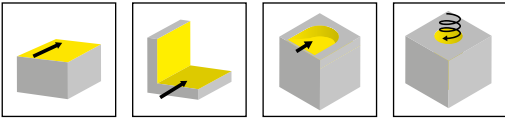

HM-Sorten
Carbide grades

▲ ab Lager
on stock

Δ 4 Wochen
4 weeks

Bestellnummer Part number	a_p	h	r_x	HIS	SA4B
SDA62.0400.A.08	4,5	5,16	0,8	DA6200	▲
					P ●
					M ●
					K ●
					N ●
					S -
					H -

Vorschubswerte DA31 / DA32

Feed Rate



ISO	Plattengröße DA31 Vorschub/Zahn f_z (mm) Insert size DA31 Feed/tooth f_z (mm)	Plattengröße DA32 Vorschub/Zahn f_z (mm) Insert size DA32 Feed/tooth f_z (mm)
P	0,03 - 0,15	0,04 - 0,25
M	0,03 - 0,12	0,03 - 0,17
K	0,03 - 0,15	0,04 - 0,25
N	0,03 - 0,40	0,04 - 0,50
S	0,03 - 0,08	0,03 - 0,15

Beim 45°-Fräsen kann der Vorschub pro Zahn f_z um den Faktor 1,4 erhöht werden.

When 45° Milling the feed per tooth f_z could be increased by factor 1,4.

Schnittgeschwindigkeiten finden Sie im Kapitel N in diesem Katalog.

Cutting speeds can be found in chapter N in this catalogue.

Eintauchwinkel, senkrecht Eintauchen seitlich und ins Volle, Aufbohren beim 90° Fräsen

Ramp angle and plunging with a 90° milling cutter

Ø (mm) Plattengröße / Insert size	32 DA32	25 DA32	20 DA32	32 DA31	25 DA31	20 DA31	16 DA31
Eintauchwinkel (°) Diving angle (°)	3,5°	3,5°	3,5°	4,0°	3,5°	3,5°	3,0°
max. senkrecht eintauchen ins Volle (mm) vertical full diving max. (mm)	1,0	0,6	0,4	1,7	0,8	0,6	0,4
Senkrecht eintauchen, max. seitliche Zustellung a_e (mm) vertical side diving a_e max. (mm)	4,6	4,6	4,6	3,1	3,1	3,1	3,1
Aufbohren, mind. Vorbohren mit D_b (mm) Predrilling D_b min. (mm)	22,8	15,8	10,8	25,8	18,8	13,8	9,8

Eintauchwinkel und senkrecht Eintauchen beim 45°-Fräsen

Ramp angle and plunging with a 45° milling cutter

Ø (mm) Plattengröße / Insert size	17 DA32	14,4 DA31	10,5 DA31
Eintauchwinkel (°) Diving angle (°)	11°	7°	10,5°
max. senkrecht eintauchen ins Volle (mm) vertical full diving max. (mm)	3,2	2,0	2,0

Korrekturfaktor für verringerte Schnitttiefe in Abhängigkeit vom Eckenradius beim 45° Fräsen.

Correction factor for reduced cutting depth in consideration to the corner radius when 45° milling.

Eckenradius r_x (mm) Corner radius r_x (mm)	Korrekturfaktor f_{ap} (mm) Correction factor f_{ap} (mm)
0	0
0,2	0,078
0,4	0,17
0,8	0,33
1,0	0,41

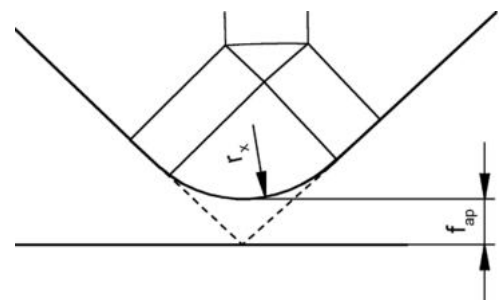

ISO	Vorschub/Zahn f_z (mm) Feed/tooth f_z (mm)
P	0,04 - 0,25
M	0,03 - 0,17
K	0,04 - 0,25
N	0,04 - 0,50
S	0,03 - 0,15

Schneidkreis-Ø Cutting edge Ø [mm]	Eintauchwinkel Diving angle [°]
20	2,4
25	1,75
32	1,25
40	0,95
50	0,7
63	0,55
80	0,4

Schnittgeschwindigkeiten finden Sie im Kapitel N in diesem Katalog.

Cutting speeds can be found in chapter N in this catalogue.

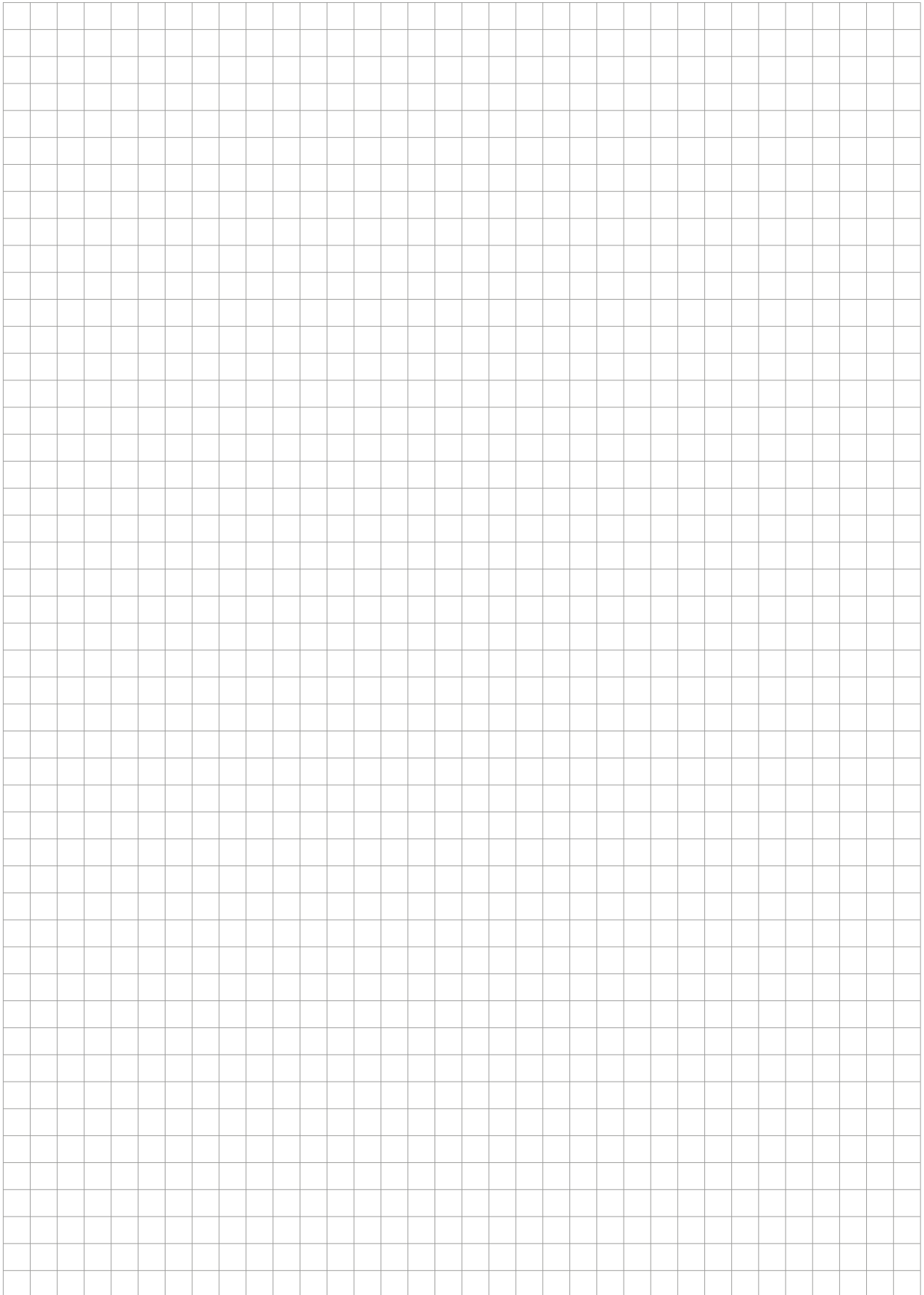

Schaftfräser
End Mill
DAH25/DAH37/
DAH82

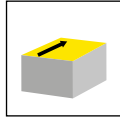

Seite/Page
494-495, 500, 507

Einschraubfräser
Screw-in cutter
DAH25/DAH37/
DAH82

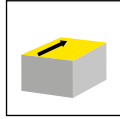

Seite/Page
496, 501, 508

Wendeschneidplatte
Indexable insert
DAH25/DAH37/DAH82/
DAH84

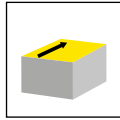

Seite/Page
497, 503-504, 510, 512

Aufsteckfräser
Arbour Mounted Cutter
DAH37/DAH82/
DAH84

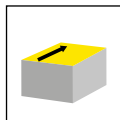

Seite/Page
502, 509, 511

DAH



Hochvorschubfräsen System DAH

- Schaftfräser
- Einschraubfräser
- Aufsteckfräser
- Wendeschneidplatten

High feed milling System DAH

- End Mill
- Screw-in Cutter
- Arbour Mounted Cutter
- Indexable Inserts

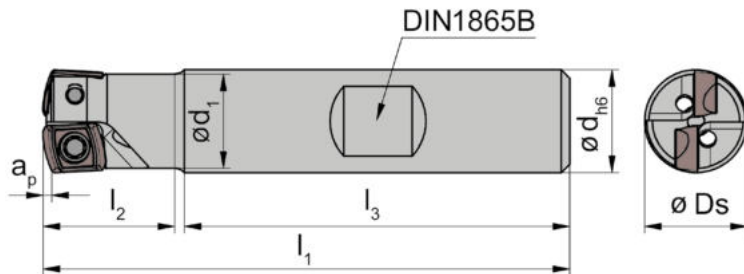
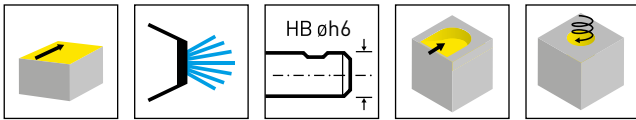

Bestellnummer Part number	Z	Ds	d	l ₁	l ₂	d ₁	l ₃	a _p	HWS
DAH25.012.D122.02B	2	12	12	61,5	15	11	45	1	DAH25
DAH25.016.D163.03B	3	16	16	69,5	20	14,5	48	1	DAH25
DAH25.020.D204.03B	3	20	20	76,5	25	18	50	1	DAH25

Ersatzteile
Spare Parts

Schaftfräser End Mill	Spannschraube Clamping Screw	TORX PLUS®-Schlüssel TORX PLUS® Wrench
DAH25.012.D122.02B	030.2547.T8P	T8PL
DAH25....	030.2553.T8P	T8PL

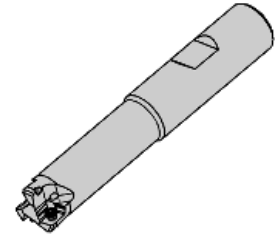
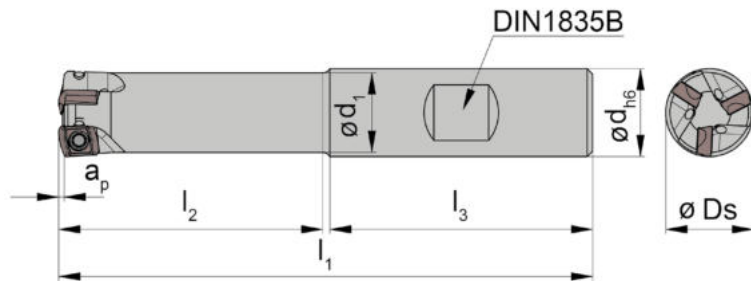
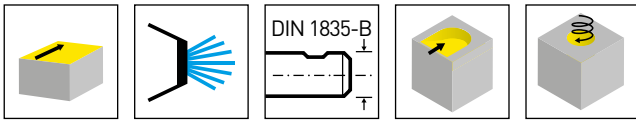

Bestellnummer Part number	Z	Ds	d	l ₁	l ₂	d ₁	l ₃	a _p	HWS
DAH25.25.012.D124.02B	2	12	12	82,5	36	11,5	45	1	DAH25
DAH25.25.016.D165.02B	2	16	16	97,5	48	15,4	48	1	DAH25
DAH25.25.016.D165.03B	3	16	16	97,5	48	15,4	48	1	DAH25
DAH25.25.020.D206.03B	3	20	20	111,5	60	19	50	1	DAH25
DAH25.25.025.D257.04B	4	25	25	132,5	75	24	56	1	DAH25

Ersatzteile

Spare Parts

Schaftfräser End Mill	Spannschraube Clamping Screw	TORX PLUS®-Schlüssel TORX PLUS® Wrench
DAH25.25.012.D124.02B	030.2547.T8P	T8PL
DAH25.25....	030.2553.T8P	T8PL

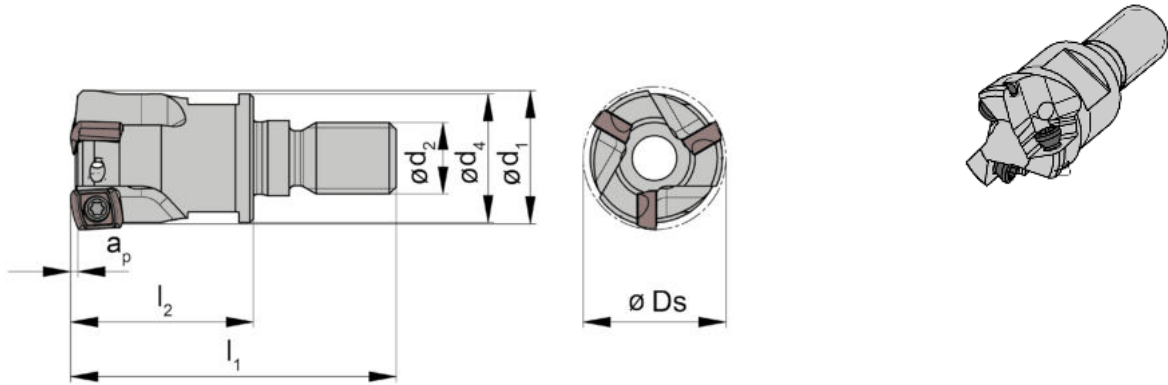
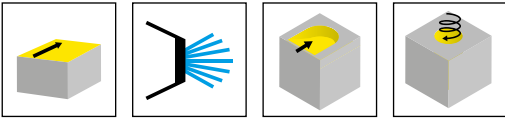

Bestellnummer Part number	Z	Ds	l ₁	l ₂	d ₁	a _p	d ₂	d ₄	HWS	HMS
DAH25.012.M062.02	2	12	26	13,5	11	1	M6	11,5	DAH25	6001
DAH25.016.M083.02	2	16	39	20,5	13	1	M8	15,4	DAH25	08001
DAH25.016.M083.03	3	16	39	20,5	13	1	M8	15,4	DAH25	08001
DAH25.020.M104.03	3	20	45	25,5	18	1	M10	19	DAH25	10001
DAH25.025.M125.04	4	25	50	28	21	1	M12	24	DAH25	12001

Ersatzteile

Spare Parts

Einschraubfräser Screw-in cutter	Spannschraube Clamping Screw	TORX PLUS®-Schlüssel TORX PLUS® Wrench
DAH25.012.M062.02	030.2547.T8P	T8PL
DAH25.016.M083.02	030.2553.T8P	T8PL

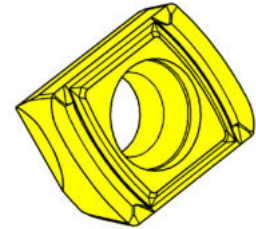
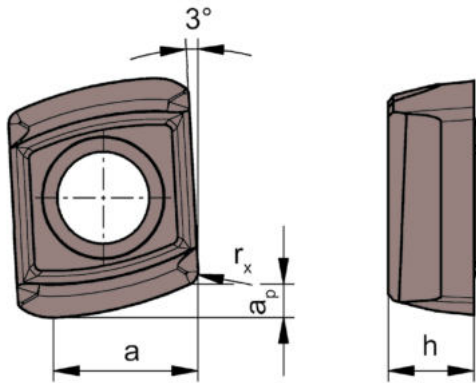
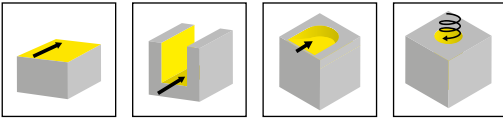

HM-Sorten
Carbide grades

▲ ab Lager
on stock

△ 4 Wochen
4 weeks

Bestellnummer Part number	a_p	a	h	r_x	HIS	SA4B
DAH.25.011.D.04	1	4,4	2,6	0,4	DAH25	▲
						P ●
						M ●
						K ●
						N ●
						S -
						H -

ISO	Vorschub/Zahn f_z (mm) Feed/tooth f_z (mm)
P	0,5 - 1,8
M	0,5 - 1,5
K	0,6 - 1,8
N	0,8 - 2,5
S	0,5 - 1,5

Schnittgeschwindigkeiten finden Sie im Kapitel N in diesem Katalog.

Cutting speeds can be found in chapter N in this catalogue.

Eintauchwinkel

Diving angle

\emptyset (mm)	Eintauchwinkel (°) Diving angle (°)
12	6,5
16	2,5
20	1,5
25	1,0

Programmerradius und Abweichung

Programming radius and difference

r_{th} (mm)	max. Abweichung (mm) max. difference (mm)
1,4	0,61

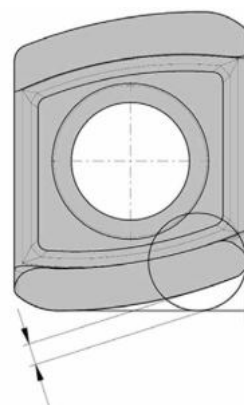

theoretischer Eckenradius r_{th}
= Programmerradius
theoretical corner radius r_{th}
= programming radius

Z = Zähnezahl
Number of teeth

d_{eff} = effektiver Schneidkreis-Ø
effective cutting edge Ø

n = Drehzahl
Revolutions

$$n = \frac{v_c \cdot 1000}{d_{\text{eff}} \cdot \pi} \text{ [1/min]}$$

v_c = Schnittgeschwindigkeit
Cutting speed

$$v_c = \frac{d_{\text{eff}} \cdot \pi \cdot n}{1000} \text{ [m/min]}$$

f_z = Vorschub/Zahn
Feed/tooth

$$f_z = \frac{v_f}{Z \cdot n} \text{ [mm]}$$

v_f = Vorschubgeschwindigkeit
Feed rate

$$v_f = f_z \cdot Z \cdot n \text{ [mm/min]}$$

Q = Materialabtragungsrate
Material removal rate

$$Q = \frac{a_e \cdot a_p \cdot v_f}{1000} \text{ [cm}^3\text{/min]}$$

Zur Ermittlung der Drehzahl und der Schnittgeschwindigkeit muss mit dem effektiven Durchmesser d_{eff} gerechnet werden.

Dieser berechnet sich in Abhängigkeit der Schnitttiefe a_p , dem Schneidkreisdurchmesser D_s und dem Korrekturwert K_D zu:

$$d_{\text{eff}} = K_D + (D_s - 12)$$

The effective cutting diameter d_{eff} must be calculated to obtain the correct RPM and the cutting feed.

The effective cutting diameter is calculated using the following values and formula.

a_p = depth of cut

D_s = cutter diameter

K_D = from Correction value chart

$$d_{\text{eff}} = K_D + (D_s - 12)$$

Korrekturwert Correction value

a_p [mm]	K_D [mm]
0,1	5,3
0,2	6,5
0,3	7,4
0,4	8,1
0,5	8,8
0,6	9,4
0,7	10,0
0,8	10,5
0,9	11,0
1,0	12,0

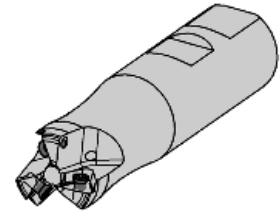
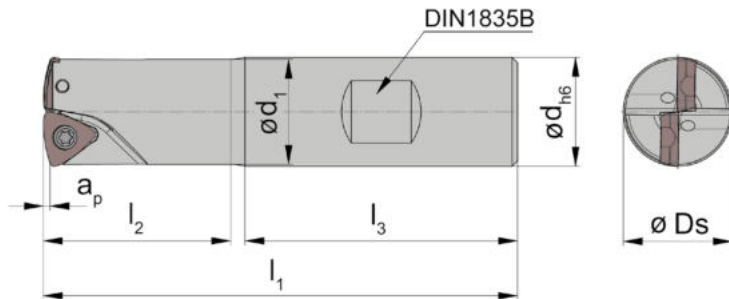
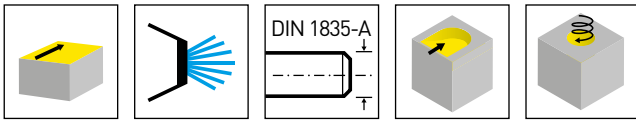

Bestellnummer Part number	Z	Ds	d	l ₁	l ₂	d ₁	l ₃	a _p	HWS
DAH37.020.D204.02B	2	20	20	87	34	19	50	1,2	DAH37
DAH37.025.D255.03B	3	25	25	101	41	24	56	1,2	DAH37
DAH37.032.D326.04B	4	32	32	111	47	31	60	1,2	DAH37

L

Ersatzteile
Spare Parts

Schaftfräser End Mill	Spannschraube Clamping Screw	TORX PLUS®-Schlüssel TORX PLUS® Wrench
DAH37...	030.3070.T10P	T10PL

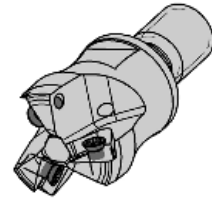
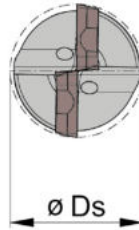
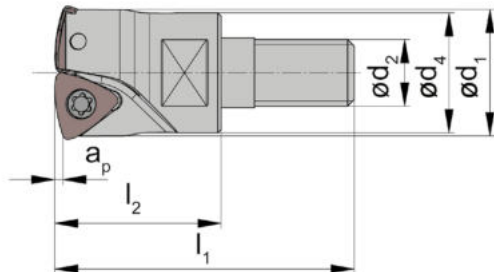
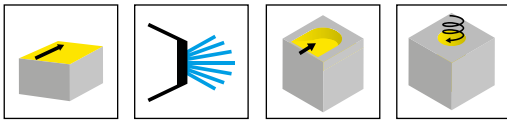

Bestellnummer Part number	Z	Ds	l ₁	l ₂	d ₁	a _p	d ₂	d ₄	SW	HWS	HMS
DAH37.020.M104.02	2	20	45	25	19	1,2	M10	18	15	DAH37	10001
DAH37.025.M125.03	3	25	52	30	24	1,2	M12	21	17	DAH37	12001
DAH37.032.M166.04	4	32	58	35	31	1,2	M16	29	24	DAH37	16001
DAH37.040.M166.05	5	40	58	35	39	1,2	M16	29	24	DAH37	16001

Ersatzteile
Spare Parts

Einschraubfräser Screw-in cutter	Spannschraube Clamping Screw	TORX PLUS®-Schlüssel TORX PLUS® Wrench
DAH37...	030.3070.T10P	T10PL



Abbildung = rechtsschneidend
Picture = right hand cutting version

Bestellnummer Part number	Z	Ds	ap	h ₂	h	d ₅	d _k	l ₂	b	C	d ₂	HWS
DAH37.040.A1635.05	5	40	1,2	34,4	35	16	33	22	8,4	5,6	16	DAH37
DAH37.050.A2235.06	6	50	1,2	39,4	40	19,5	41	24	10,4	6,3	22	DAH37
DAH37.063.A2240.07	7	63	1,2	39,4	40	19,5	49	24	10,4	6,3	22	DAH37
DAH37.063.A2740.07	7	63	1,2	44,4	45	21,5	49	27	12,4	7	27	DAH37
DAH37.080.A3245.08	8	80	1,2	54,4	55	29,5	59	33	12,4	8	32	DAH37

L

Ersatzteile
Spare Parts

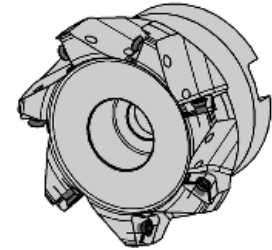
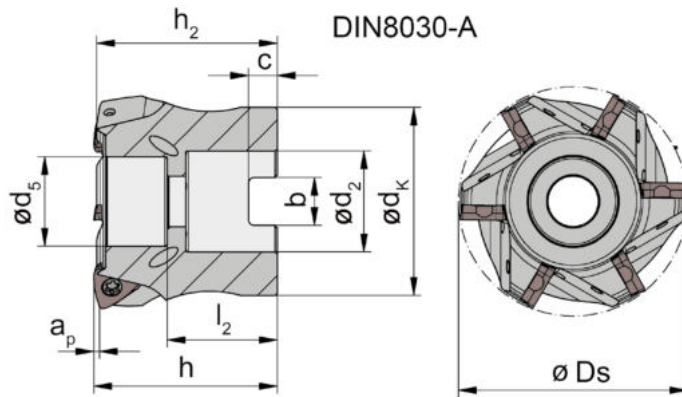
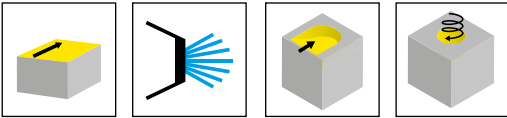
Aufsteckfräser Arbour Mounted Cutter	Spannschraube Clamping Screw	TORX PLUS®-Schlüssel TORX PLUS® Wrench
DAH37...	030.3070.T10P	T10PL

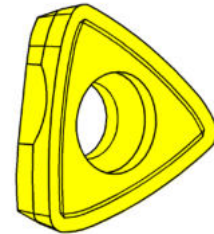
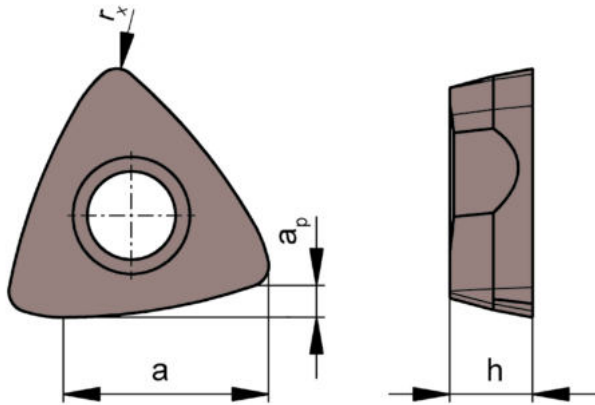
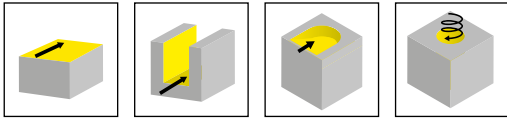

HM-Sorten
Carbide grades

▲ ab Lager
on stock

Δ 4 Wochen
4 weeks

Bestellnummer Part number	a_p	a	h	r_x	HIS	SA4B	SC6A
DAH.37.022.N.08	1,2	7,9	3,18	0,8	DAH37	▲	▲
neutrale Geometrie neutral geometry						P ●	●
						M ●	●
						K ●	●
						N ●	●
						S -	-
						H -	-



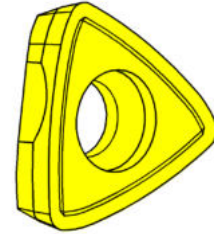
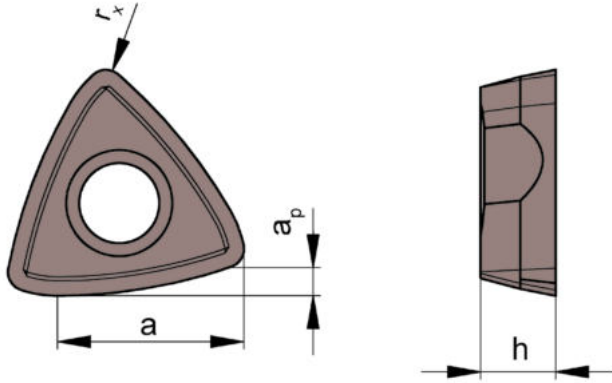
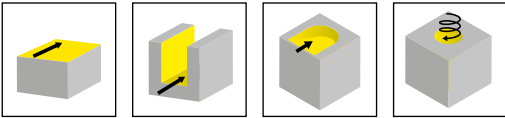

HM-Sorten
Carbide grades

▲ ab Lager
on stock

△ 4 Wochen
4 weeks

Bestellnummer Part number	a_p	a	h	r_x	HIS	SA4B
DAH.37.022.S.08	1,2	7,9	3,18	0,8	DAH37	▲
positive Geometrie positive geometry						P ●
						M ●
						K ●
						N ●
						S -
						H -

ISO	Vorschub/Zahn f_z (mm) Feed/tooth f_z (mm)
P	0,6 - 2,2
M	0,6 - 2,0
K	0,7 - 2,0
N	1,0 - 2,8
S	0,6 - 1,8

Schnittgeschwindigkeiten finden Sie im Kapitel N in diesem Katalog.

Cutting speeds can be found in chapter N in this catalogue.

Eintauchwinkel

Diving angle

\emptyset (mm)	Eintauchwinkel (°) Diving angle (°)
20	5,0
25	4,0
32	1,0
40	0,5
50	0,5
63	0,4
80	0,4

Programmerradius und Abweichung

Programming radius and difference

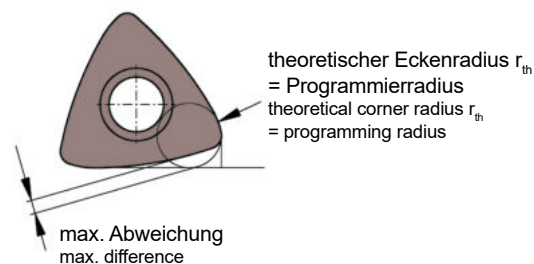

r_{th} (mm)	max. Abweichung (mm) max. difference (mm)
2	0,83

Z = Zähnezahl
Number of teeth

d_{eff} = effektiver Schneidkreis-Ø
effective cutting edge Ø

n = Drehzahl
Revolutions

$$n = \frac{v_c \cdot 1000}{d_{\text{eff}} \cdot \pi} \text{ [1/min]}$$

v_c = Schnittgeschwindigkeit
Cutting speed

$$v_c = \frac{d_{\text{eff}} \cdot \pi \cdot n}{1000} \text{ [m/min]}$$

f_z = Vorschub/Zahn
Feed/tooth

$$f_z = \frac{v_f}{Z \cdot n} \text{ [mm]}$$

v_f = Vorschubgeschwindigkeit
Feed rate

$$v_f = f_z \cdot Z \cdot n \text{ [mm/min]}$$

Q = Materialabtragungsrate
Material removal rate

$$Q = \frac{a_e \cdot a_p \cdot v_f}{1000} \text{ [cm}^3\text{/min]}$$

Zur Ermittlung der Drehzahl und der Schnittgeschwindigkeit muss mit dem effektiven Durchmesser d_{eff} gerechnet werden.

Dieser berechnet sich in Abhängigkeit der Schnitttiefe a_p , dem Schneidkreisdurchmesser D_s und dem Korrekturwert K_D zu:

$$d_{\text{eff}} = K_D + (D_s - 20)$$

The effective cutting diameter d_{eff} must be calculated to obtain the correct RPM and the cutting feed.

The effective cutting diameter is calculated using the following values and formula.

a_p = depth of cut

D_s = cutter diameter

K_D = from Correction value chart

$$d_{\text{eff}} = K_D + (D_s - 20)$$

Korrekturwert Correction value

a_p [mm]	K_D [mm]
0,1	9,71
0,2	11,47
0,3	12,81
0,4	13,93
0,5	14,92
0,6	15,82
0,7	16,63
0,8	17,39
0,9	18,10
1,0	18,77
1,1	19,40
1,2	20,00



Abbildung = rechtsschneidend
Picture = right hand cutting version

Bestellnummer Part number	Z	Ds	d	l_1	l_3	a_p	n_{max}	HWS
DAH82.020.D204.02B	2	20	20	87	50	1	21000	DAH82
DAH82.025.D255.03B	3	25	25	101	56	1	18500	DAH82
DAH82.032.D326.04B	4	32	32	111	60	1	16500	DAH82
DAH82.035.D326.04B	4	35	32	111	60	1	15500	DAH82
DAH82.040.D326.05B	5	40	32	111	60	1	14500	DAH82

Ersatzteile
Spare Parts

Schaftfräser End Mill	Spannschraube Clamping Screw	TORX PLUS®-Schlüssel TORX PLUS® Wrench
DAH82...	030.3070.T10P	T10PL

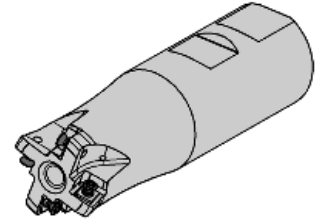
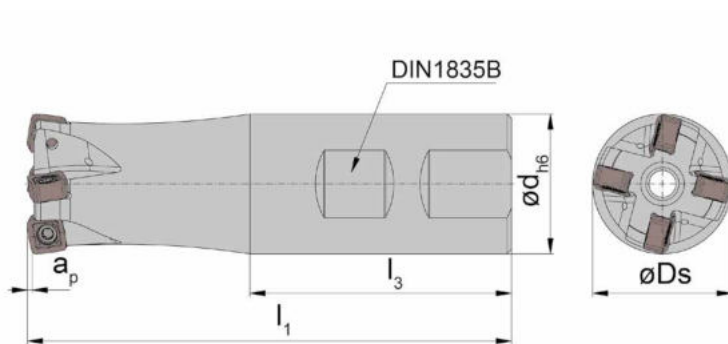
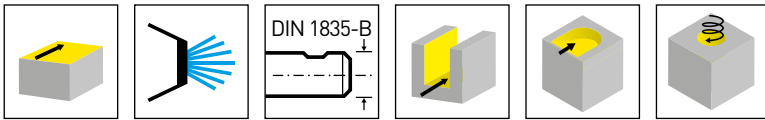

Abbildung = rechtsschneidend
Picture = right hand cutting version

Bestellnummer Part number	Z	Ds	l ₁	l ₂	d ₄	a _p	d ₂	SW	n _{max}	HWS	HMS
DAH82.020.M104.02	2	20	45	25	18	1	M10	15	21000	DAH82	10001
DAH82.025.M125.03	3	25	52	30	21	1	M12	17	18500	DAH82	12001
DAH82.032.M166.04	4	32	58	35	29	1	M16	24	16500	DAH82	16001
DAH82.035.M166.04	4	35	58	35	29	1	M16	24	15500	DAH82	16001
DAH82.040.M166.05	5	40	58	35	29	1	M16	24	14500	DAH82	16001

Ersatzteile
Spare Parts

Einschraubfräser Screw-in cutter	Spannschraube Clamping Screw	TORX PLUS®-Schlüssel TORX PLUS® Wrench
DAH82...	030.3070.T10P	T10PL

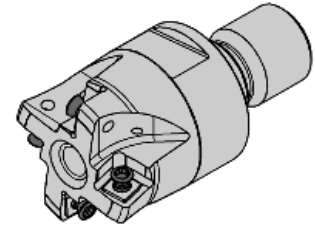
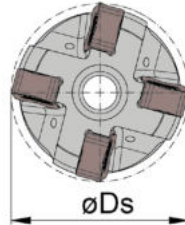
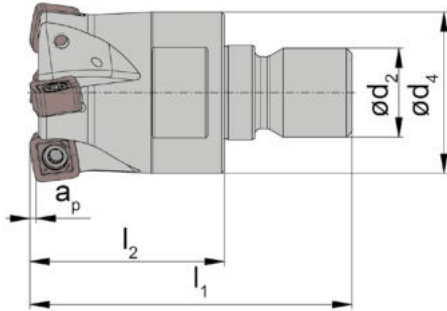
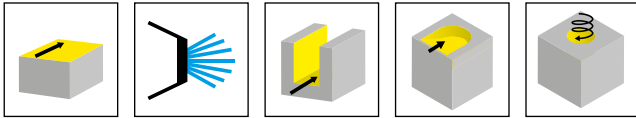

Abbildung = rechtsschneidend
Picture = right hand cutting version

Bestellnummer Part number	Z	Ds	ap	h ₂	h	d ₅	d _k	l ₂	b	C	d ₂	n _{max}	HWS
DAH82.040.A1635.05	5	40	1	33,5	35	16	33	22	8,4	5,6	16	14500	DAH82
DAH82.042.A1635.05	5	42	1	33,5	35	16	33	22	8,4	5,6	16	14000	DAH82
DAH82.050.A2240.06	6	50	1	38,5	40	19,5	41	24	10,4	6,3	22	13000	DAH82
DAH82.052.A2240.06	6	52	1	38,5	40	19,5	41	24	10,4	6,3	22	13000	DAH82
DAH82.063.A2240.07	7	63	1	38,5	40	19,5	49	24	10,4	6,3	22	13000	DAH82

Ersatzteile
Spare Parts

Aufsteckfräser Arbour Mounted Cutter	Spannschraube Clamping Screw	TORX PLUS®-Schlüssel TORX PLUS® Wrench
DAH82...	030.3070.T10P	T10PL

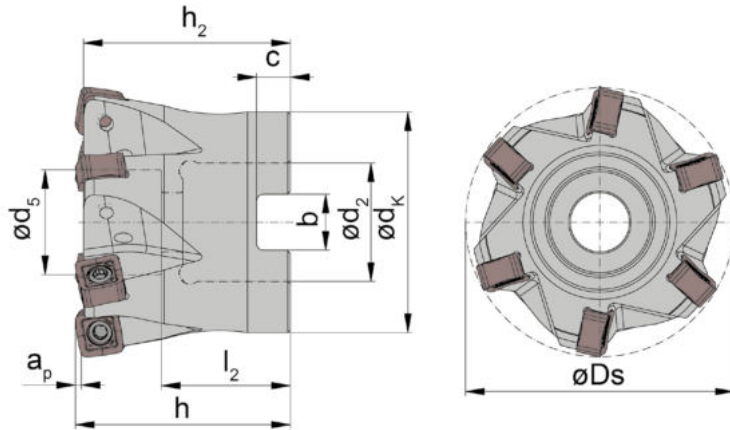
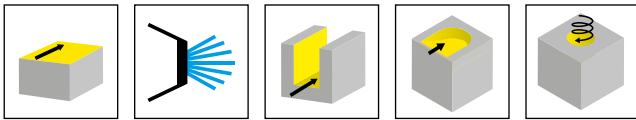
Wendeschnidplatte Indexable insert

DAH82

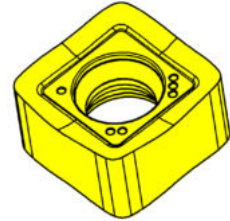
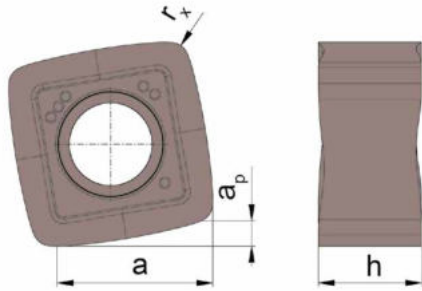
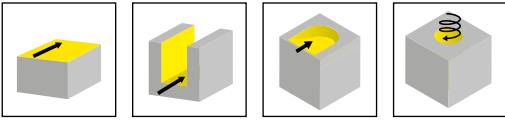

HM-Sorten
Carbide grades

▲ ab Lager
on stock

△ 4 Wochen
4 weeks

Bestellnummer Part number	a_p	a	h	r_x	HIS	IG6B	SA4B	SC6A
DAH.82.030.S.08	1	6,8	4,5	0,8	DAH82	▲	▲	▲
positive Geometrie positive geometry						P ●	●	●
						M o	●	●
						K o	●	●
						N o	●	●
						S o	-	-
						H -	-	-



Abbildung = rechtsschneidend
Picture = right hand cutting version

Bestellnummer Part number	Z	Ds	ap	h ₂	h	d ₅	d _k	l ₂	b	C	d ₂	n _{max}	HWS
DAH84.050.A2240.04	4	50	1,5	38	40	16,5	41	25	10,4	6,3	22	8000	DAH84
DAH84.052.A2240.04	4	52	1,5	38	40	16,5	41	25	10,4	6,3	22	7500	DAH84
DAH84.063.A2240.05	5	63	1,5	38	40	19,5	49	25	10,4	6,3	22	6500	DAH84
DAH84.066.A2240.05	5	66	1,5	38	40	19,5	49	25	10,4	6,3	22	6500	DAH84
DAH84.080.A2750.06	6	80	1,5	48	50	21,5	59	28	12,4	7	27	5500	DAH84
DAH84.085.A2750.06	6	85	1,5	48	50	21,5	59	28	12,4	7	27	5500	DAH84
DAH84.100.A3250.07	7	100	1,5	48	50	30	80	33	14,4	8	32	5000	DAH84
DAH84.125.A4063.08	8	125	1,5	61	63	56	89	35	16,4	9	40	4000	DAH84

Ersatzteile

Spare Parts

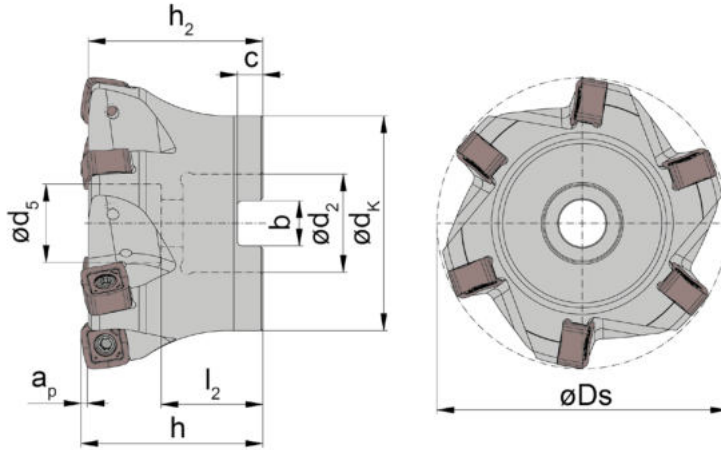
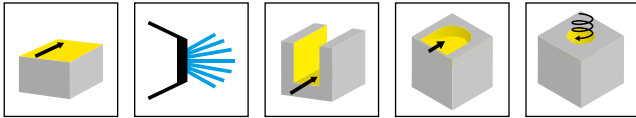
Aufsteckfräser Arbour Mounted Cutter	Spannschraube Clamping Screw	TORX PLUS®-Schlüssel TORX PLUS® Wrench	Fräseranzugsschraube Tightening Bolt
DAH84...	030.0412.T15P	T15PQ	
DAH84.125.A4063.08	030.0412.T15P	T15PQ	20.30.6367



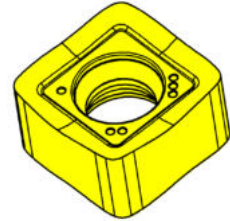
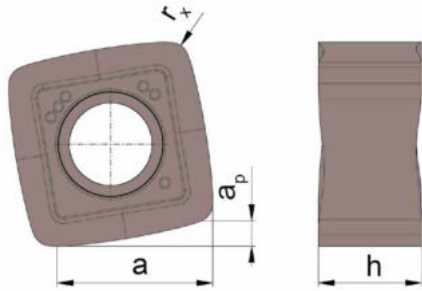
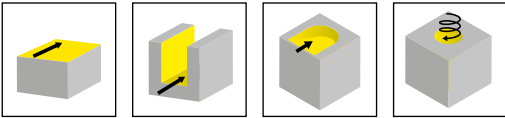

HM-Sorten
Carbide grades

▲ ab Lager
on stock

△ 4 Wochen
4 weeks

Bestellnummer Part number	a_p	a	h	r_x	HIS	IG6B	SA4B	SC6A
DAH.84.030.S.12	1,5	9,8	7	1,2	DAH84	▲	▲	▲
positive Geometrie positive geometry						P ●	●	●
						M o	●	●
						K o	●	●
						N o	●	●
						S o	-	-
						H -	-	-

Vorschubswerte DAH82 / DAH84

Feed Rate



ISO	DAH82	DAH84
	Vorschub/Zahn f_z (mm) Feed/tooth f_z (mm)	Vorschub/Zahn f_z (mm) Feed/tooth f_z (mm)
P	0,6 - 2,2	0,8 - 2,2
M	0,6 - 2,0	0,6 - 2,2
K	0,7 - 2,0	0,7 - 2,2
N	1,0 - 2,8	1,5 - 3,0
S	0,6 - 1,8	0,7 - 2,0

Schnittgeschwindigkeiten finden Sie im Kapitel N in diesem Katalog.

Cutting speeds can be found in chapter N in this catalogue.

Berechnung Fräsermittelpunktsbahn

- D = Bohrungsdurchmesser Werkstück
- D_s = Schneidkreisdurchmesser
- r_s = Schneidkreisradius
- U_{FMB} = Umfang Fräsermittelpunktsbahn

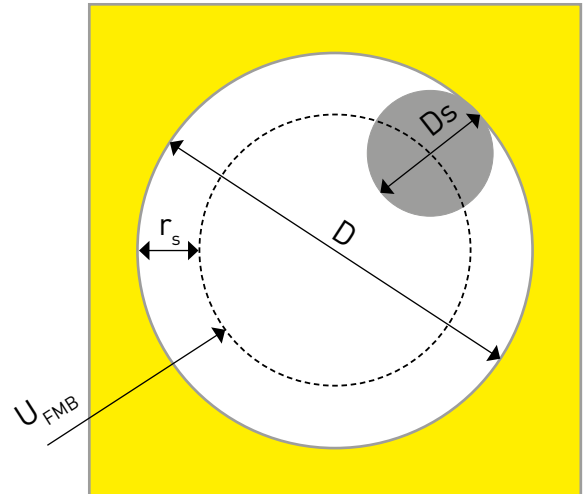

$$U_{FMB} = \pi \times (\text{Bohrungsdurchmesser Werkstück} - \text{Schneidkreisdurchmesser})$$

$$\longrightarrow U_{FMB} = \pi \times (D - D_s)$$

oder

$$U_{FMB} = \pi \times (\text{Bohrungsdurchmesser Werkstück} - (2 \times \text{Schneidkreisradius}))$$

$$\longrightarrow U_{FMB} = \pi \times (D - (2 \times r_s))$$

Berechnung über Fräsermittelpunktsbahn: Basis ist das rechtwinklige Dreieck

- a = Rampenwinkel
- b = Schnitttiefe je Umdrehung (Steigung)
- a = Umfang Fräsermittelpunktsbahn

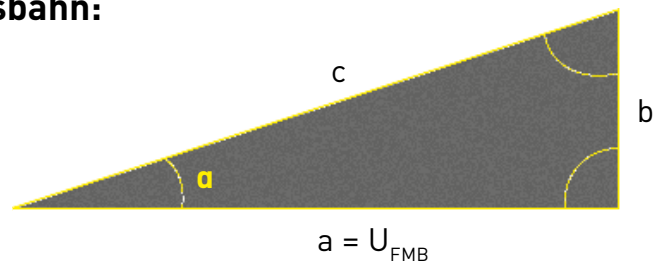

Beispielbetrachtung fehlender Rampenwinkel = ?

- Bohrungsdurchmesser Werkstück D = 98 mm
- Schnitttiefe je Umdrehung b = 0,8 mm
- Schneidkreisdurchmesser D_s = 50 mm

$$\tan \alpha = \frac{\text{Gegenkathete } b}{\text{Ankathete } a}$$

$$\tan \alpha = \frac{0,8 \text{ mm}}{150,8 \text{ mm}}$$

$$\alpha = 0,30^\circ$$

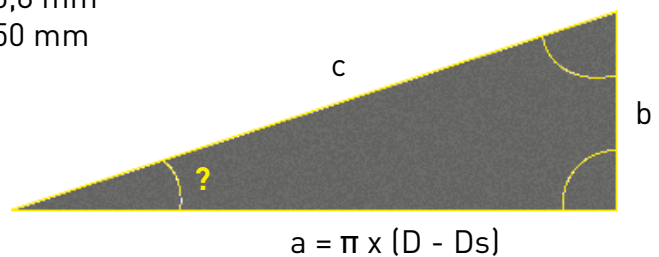

Fräsermittelpunktsbahn - Theoretisch ermittelte Werte

DAH82	
Schneidkreis-Ø [mm]	Eintauchwinkel [°]
20	5
25	3,9
32	2,8
35	2,4
40	1,9
42	1,8
50	1,4

DAH84	
Schneidkreis-Ø [mm]	Eintauchwinkel [°]
50	2,7
52	2,5
63	1,8
66	1,7
80	1,3
85	1,2
100	1,0
125	0,8

Empfehlung helikales Eintauchen DAH82:

$$a_{p \max} = 1 \text{ mm}$$

→ Zustellung je Umdrehung: 50% des $a_{p \max}$ als Startwert

→ je nach Verhältnisse bis 80 % des $a_{p \max}$ möglich

→ 0,5 mm bis 0,8 mm Zustellung je Umdrehung

Empfehlung helikales Eintauchen DAH84:

$$a_{p \max} = 1,5 \text{ mm}$$

→ Zustellung je Umdrehung: 67% des $a_{p \max}$ als Startwert

→ je nach Verhältnisse bis 80 % des $a_{p \max}$ möglich

→ 1,0 mm bis 1,2 mm Zustellung je Umdrehung

Berechnung Bohrungsdurchmesser ebener Grund DAH82

$$D_{\min} = (D_s - a) \times 2$$

$$D_{\min} = (50 \text{ mm} - 6,8 \text{ mm}) \times 2$$

$$D_{\min} = 86,4 \text{ mm}$$



Bedeutet:

Mit dem Schneidkreisdurchmesser 50 mm ist ein Durchmesser von 86,4 mm mit ebenem Grund zu erreichen.

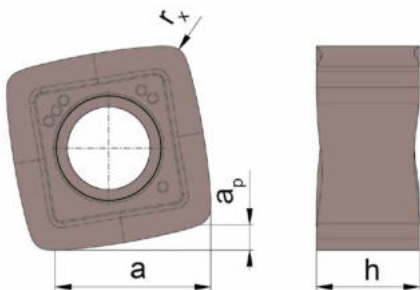
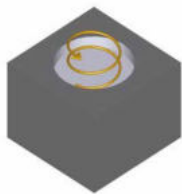

$$D_{\max} = (D_s - r_x) \times 2$$

$$D_{\max} = (50 \text{ mm} - 0,8 \text{ mm}) \times 2$$

$$D_{\max} = 98,4 \text{ mm}$$



Bedeutet:

Mit dem Schneidkreisdurchmesser 50 mm ist ein Durchmesser von 98,4 mm **ohne** ebenem Grund zu erreichen. Es bleibt Restmaterial in der Mitte stehen.

$$r_x = 0,8 \text{ mm}$$

$$a = 6,8 \text{ mm}$$

Berechnung Bohrungsdurchmesser ebener Grund DAH84

$$D_{\min} = (D_s - a) \times 2$$

$$D_{\min} = (50 \text{ mm} - 9,8 \text{ mm}) \times 2$$

$$D_{\min} = 80,4 \text{ mm}$$



Bedeutet:

Mit dem Schneidkreisdurchmesser 50 mm ist ein Durchmesser von 80,4 mm mit ebenem Grund zu erreichen.

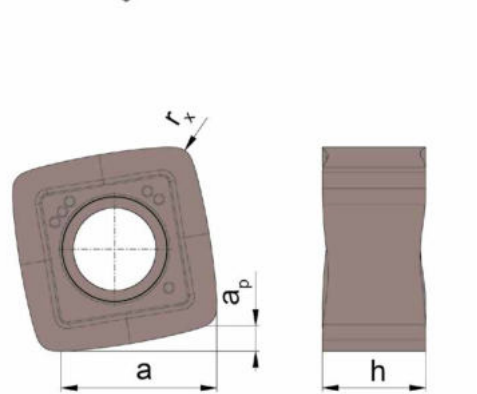
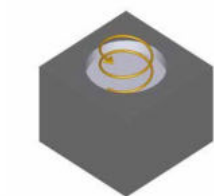

$$D_{\max} = (D_s - r_x) \times 2$$

$$D_{\max} = (50 \text{ mm} - 1,2 \text{ mm}) \times 2$$

$$D_{\max} = 97,6 \text{ mm}$$



Bedeutet:

Mit dem Schneidkreisdurchmesser 50 mm ist ein Durchmesser von 97,6 mm **ohne** ebenem Grund zu erreichen. Es bleibt Restmaterial in der Mitte stehen.

$$r_x = 1,2 \text{ mm}$$

$$a = 9,8 \text{ mm}$$

Calculation of cutter centre path

- D = Bore diameter of workpiece
- D_s = Cutting diameter
- r_s = Cutting radius
- U_{FMB} = Circumference of cutter centre path

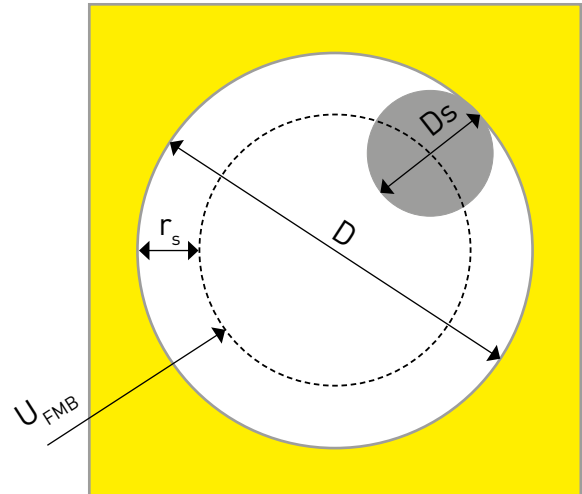

$$U_{FMB} = \pi \times (\text{Bore diameter of workpiece} - \text{Cutting diameter})$$

$$\longrightarrow U_{FMB} = \pi \times (D - D_s)$$

or

$$U_{FMB} = \pi \times (\text{Bore diameter of workpiece} - (2 \times \text{Cutting radius}))$$

$$\longrightarrow U_{FMB} = \pi \times (D - (2 \times r_s))$$

Calculation using cutter centre path: The basis is the right-angled triangle

- α = Ramp angle
- b = Depth of cut per rotation (Pitch)
- a = Circumference of cutter centre path

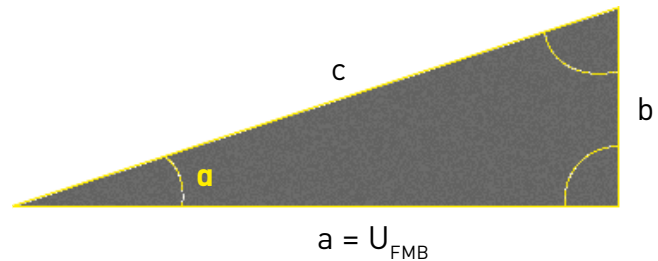

Example of missing ramp angle = ?

- Bore diameter of workpiece D = 98 mm
- Depth of cut per rotation b = 0.8 mm
- Cutting diameter D_s = 50 mm

$$\tan \alpha = \frac{\text{Opposite side } b}{\text{Adjacent side } a}$$

$$\tan \alpha = \frac{0.8 \text{ mm}}{150.8 \text{ mm}}$$

$$\alpha = 0.30^\circ$$

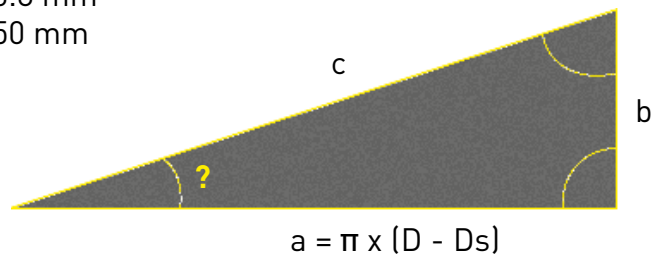

Cutter centre path - Theoretical values

DAH82	
Cutting Ø [mm]	Plunge angle [°]
20	5
25	3.9
32	2.8
35	2.4
40	1.9
42	1.8
50	1.4

DAH84	
Cutting Ø [mm]	Plunge angle [°]
50	2.7
52	2.5
63	1.8
66	1.7
80	1.3
85	1.2
100	1.0
125	0.8

Recommendation for helical plunging DAH82:

$$a_{p \max} = 1 \text{ mm}$$

→ Feed per revolution: 50% of $a_{p \max}$ as starting value

→ Depending on conditions, up to 80 % of the $a_{p \max}$ possible

→ 0.5 mm up to 0.8 mm feed per revolution

Recommendation for helical plunging DAH84:

$$a_{p \max} = 1.5 \text{ mm}$$

→ Feed per revolution: 67% of $a_{p \max}$ as starting value

→ Depending on conditions, up to 80 % of the $a_{p \max}$ possible

→ 1.0 mm up to 1.2 mm feed per revolution

Calculation of bore diameter with flat base DAH82

$$D_{\min} = (Ds - a) \times 2$$

$$D_{\min} = (50 \text{ mm} - 6.8 \text{ mm}) \times 2$$

$$D_{\min} = 86.4 \text{ mm}$$



Meaning:

With a cutting diameter 50 mm, a bore diameter of 86.4 mm **with** a flat base can be achieved.

$$D_{\max} = (Ds - r_x) \times 2$$

$$D_{\max} = (50 \text{ mm} - 0.8 \text{ mm}) \times 2$$

$$D_{\max} = 98.4 \text{ mm}$$



Meaning:

With a cutting diameter 50 mm, a diameter of 98.4 mm **without** a flat base can be achieved. Material remains in the centre.

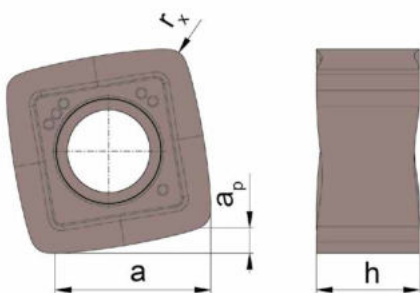
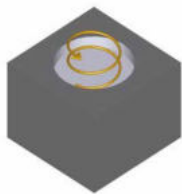

$$r_x = 0.8 \text{ mm}$$

$$a = 6.8 \text{ mm}$$

Calculation of bore diameter with flat base DAH84

$$D_{\min} = (Ds - a) \times 2$$

$$D_{\min} = (50 \text{ mm} - 9.8 \text{ mm}) \times 2$$

$$D_{\min} = 80.4 \text{ mm}$$



Meaning:

With a cutting diameter 50 mm, of a bore diameter of 80.4 mm **with** a flat base can be achieved.

$$D_{\max} = (Ds - r_x) \times 2$$

$$D_{\max} = (50 \text{ mm} - 1.2 \text{ mm}) \times 2$$

$$D_{\max} = 97.6 \text{ mm}$$



Meaning:

With a cutting diameter 50 mm, a diameter of 97.6 mm **without** a flat base can be achieved. Material remains in the centre.

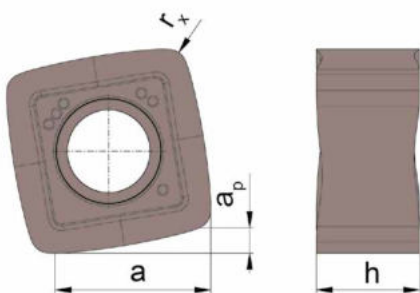
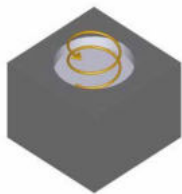

$$r_x = 1.2 \text{ mm}$$

$$a = 9.8 \text{ mm}$$

Korrekturwert - warum?

Correction factors - why?

- Bei der Verwendung eines Hochvorschubfräasers ist der effektive Schneidkreis durchmesser nicht identisch mit dem angegebenen Schneidkreis
- Die Korrekturwerte stehen in Abhängigkeit der Schnitttiefe a_p .
- Dies gilt für die Bearbeitung des Planfräsen.
- Berechnung für D_s effektiv für das Planfräsen: **$D_s \text{ effektiv} = D_s - K$**

- When using a high feed milling cutter, the effective cutting diameter is not identical with the specified value.
- The correction factors are dependent on the cutting depth a_p .
- This applies to face milling.
- Calculation for D_s effective for face milling: **$D_s \text{ effective} = D_s - K$**

DAH82	
Schnitttiefe Depth of cut a_p [mm]	Korrekturwert Correction factor K [mm]
0,1	10,9
0,2	9,5
0,3	8,3
0,4	7,0
0,5	5,9
0,6	4,8
0,7	3,9
0,8	3,0
0,9	2,2
1,0	1,6

DAH84	
Schnitttiefe Depth of cut a_p [mm]	Korrekturwert Correction factor K [mm]
0,1	16,3
0,2	14,6
0,3	13,0
0,4	11,7
0,5	10,4
0,6	9,3
0,7	8,2
0,8	7,3
0,9	6,4
1,0	5,6
1,1	4,9
1,2	4,1
1,3	3,5
1,4	2,8
1,5	2,3



System/System	Seite/Page
M406	524
M409	534
M610	558

Schaftfräser
End Mill
M406

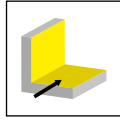

Seite/Page
526-528

Einschraubfräser
Screw-in cutter
M406

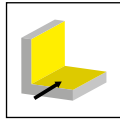

Seite/Page
529

Aufsteckfräser
Arbour Mounted Cutter
M406

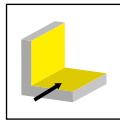

Seite/Page
530

Wendeschneidplatte
Indexable insert
406

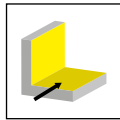

Seite/Page
531

Schneidplatte
Insert
406

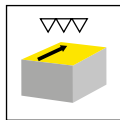

Seite/Page
532

M406



Tangentialfräsen mit System 406

- 90° Schafffräser
- 90° Einschraubfräser
- Aufsteckfräser

Tangential milling with system 406

- 90° End Mill
- 90° Screw-in Cutter
- Disc Milling Cutter



Abbildung = rechtsschneidend
Picture = right hand cutting version

Bestellnummer Part number	Z	Ds	d	l ₁	l ₂	d ₁	l ₃	a _p	n _{max}	HWS
M406.016.D16.3.02A	2	16	16	75	25	15	48	6,3	23700	40600R
M406.020.D20.4.03A	3	20	20	85	33	19	50	6,3	21200	40600R
M406.025.D25.5.04A	4	25	25	95	37	24	56	6,3	19000	40600R
M406.032.D32.6.05A	5	32	32	111	47	31	60	6,3	16700	40600R
M406.040.D32.6.06A	6	40	32	111	49	39	60	6,3	15000	40600R

Ersatzteile

Spare Parts

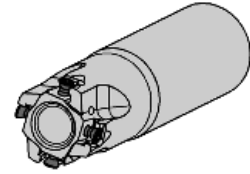
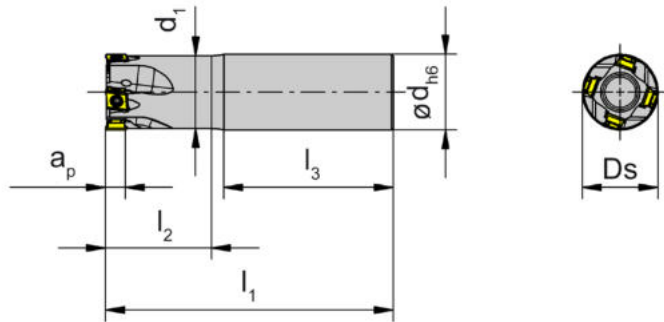
Schaftfräser End Mill	Spannschraube Clamping Screw	TORX PLUS®-Schlüssel TORX PLUS® Wrench
M406...02A -...03A	030.2669.T8P	T8PL
M406...04A -...06A	030.2608.T8P	T8PL



Abbildung = rechtsschneidend
Picture = right hand cutting version

Bestellnummer Part number	Z	Ds	d	l ₁	l ₂	d ₁	l ₃	a _p	n _{max}	HWS
M406.016.D16.3.02B	2	16	16	75	25	15	48	6,3	23700	40600R
M406.020.D20.4.03B	3	20	20	85	33	19	50	6,3	21200	40600R
M406.025.D25.5.04B	4	25	25	95	37	24	56	6,3	19000	40600R
M406.032.D32.6.05B	5	32	32	111	47	31	60	6,3	16700	40600R

Ersatzteile
Spare Parts

Schaftfräser End Mill	Spannschraube Clamping Screw	TORX PLUS®-Schlüssel TORX PLUS® Wrench
M406...02B -...03B	030.2669.T8P	T8PL
M406...04B -...06B	030.2608.T8P	T8PL

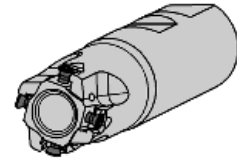
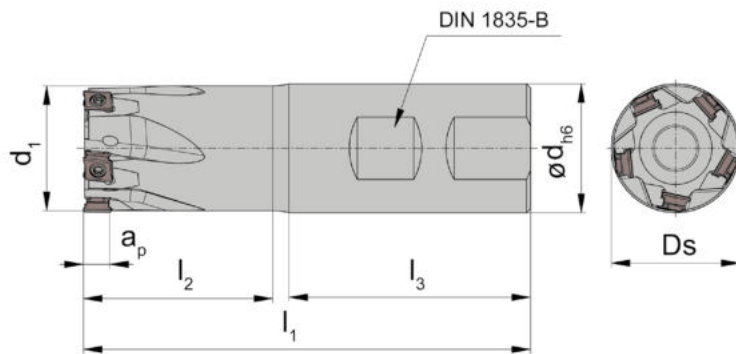
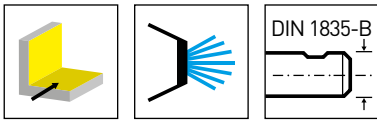

Abbildung = rechtsschneidend
Picture = right hand cutting version

Bestellnummer Part number	Z	Ds	d	l ₁	l ₂	d ₁	l ₃	a _p	n _{max}	HWS
M406.016.D12.1.02A	2	16	12	55	20	15	35	6,3	23700	40600R
M406.020.D16.1.03A	3	20	16	55	20	19	35	6,3	21200	40600R
M406.025.D16.2.04A	4	25	16	65	30	24	35	6,3	19000	40600R
M406.025.D20.2.04A	4	25	20	65	30	24	35	6,3	19000	40600R
M406.032.D16.2.05A	5	32	16	65	30	31	35	6,3	16700	40600R
M406.032.D20.2.05A	5	32	20	65	30	31	35	6,3	16700	40600R
M406.040.D16.2.06A	6	40	16	65	30	39	35	6,3	15000	40600R
M406.040.D20.2.06A	6	40	20	65	30	39	35	6,3	15000	40600R

Ersatzteile

Spare Parts

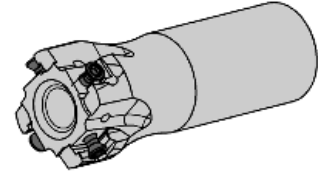
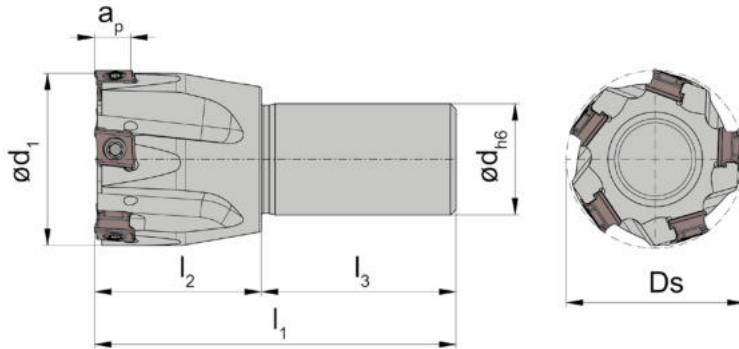
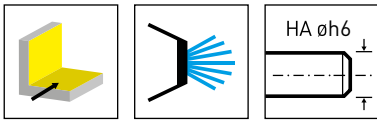
Schaftfräser End Mill	Spannschraube Clamping Screw	TORX PLUS®-Schlüssel TORX PLUS® Wrench
M406...02A - ...03A	030.2669.T8P	T8PL
M406...04A - ...06A	030.2608.T8P	T8PL



Abbildung = rechtsschneidend
Picture = right hand cutting version

Bestellnummer Part number	Z	Ds	l ₁	l ₂	d ₁	a _p	d ₂	d ₄	SW	n _{max}	HWS	HMS
M406.016.M08.3.02	2	16	41	23	15	6,3	M8	13	10	23700	40600R	08001
M406.020.M10.4.03	3	20	50	30	19	6,3	M10	18	15	21200	40600R	10001
M406.025.M12.5.04	4	25	57	35	24	6,3	M12	21	17	19000	40600R	12001
M406.032.M16.6.05	5	32	66	43	31	6,3	M16	29	24	16700	40600R	16001
M406.040.M16.6.06	6	40	66	43	39	6,3	M16	29	24	15000	40600R	16001

Ersatzteile

Spare Parts

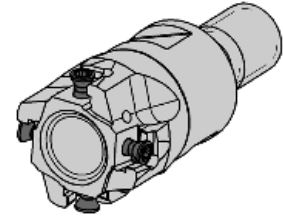
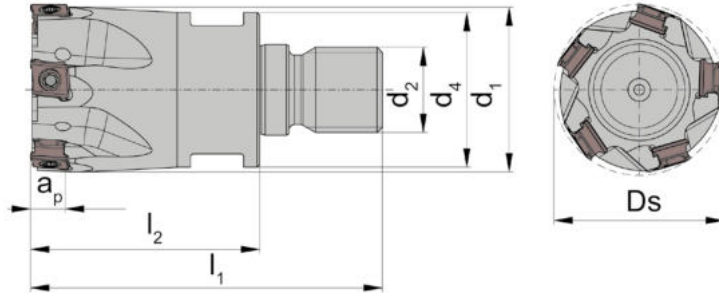
Einschraubfräser Screw-in cutter	Spannschraube Clamping Screw	TORX PLUS®-Schlüssel TORX PLUS® Wrench
M406...02 -...03	030.2669.T8P	T8PL
M406...04 -...06	030.2608.T8P	T8PL

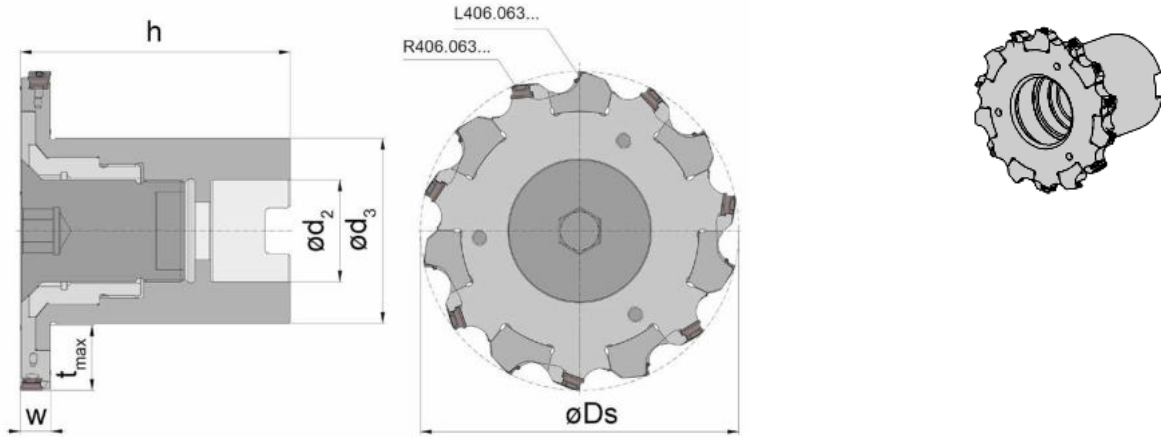
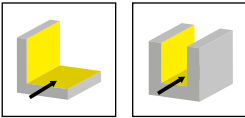

Bestellnummer Part number	Z	Z _{eff}	Ds	t _{max}	h _{min}	h _{max}	d ₃	d ₂	w _{min}	w _{max}	rechte WSP right hand insert	linke WSP left hand insert	HWS
M406.0100.A32.ES.96	14	7	100	20	84,8	88,1	58	32	9,6	12,9	7x R406.063...	7x L406.063...	40600R • 40600L

Aufsteckfräser einstellbar!
Arbour mounted cutter is adjustable!

Ersatzteile
Spare Parts

Aufsteckfräser Arbour Mounted Cutter	Schraube Screw	Spannschraube Clamping Screw	TORX PLUS®-Schlüssel TORX PLUS® Wrench	Verstelladapter Adjustment Adapter
M406.0100.A32.ES.96	C406.0100.A32.ES.96	030.2608.T8P	T8PL	A406.0100.A32.ES.96

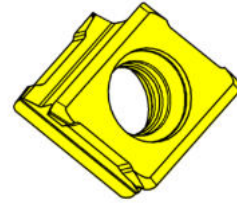
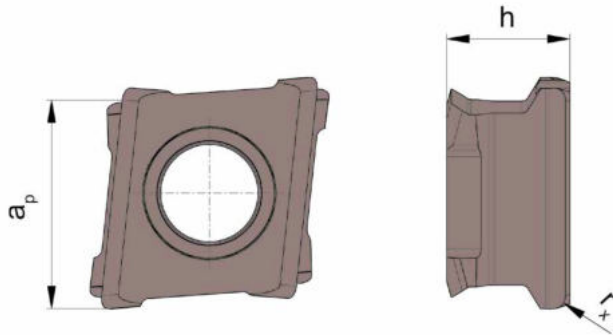
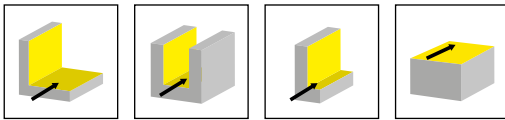

HM-Sorten
Carbide grades

▲ ab Lager
on stock

△ 4 Wochen
4 weeks

Bestellnummer Part number	a_p	h	r_x	HIS	K10	AS46	AS4B	IG35	NE2B
R406.063.U.02	6,3	3,85	0,2	40600R		△	▲		
R406.063.U.04	6,3	3,85	0,4	40600R		▲	▲		
R406.063.U.08	6,3	3,85	0,8	40600R		▲	▲		
R406.063.W.02	6,3	3,85	0,2	40600R	▲			▲	▲
R406.063.W.04	6,3	3,85	0,4	40600R	▲			▲	▲
R406.063.W.08	6,3	3,85	0,8	40600R	▲			▲	▲
L406.063.U.02	6,3	3,85	0,2	40600L		△	▲		
L406.063.U.04	6,3	3,85	0,4	40600L		▲	▲		
L406.063.U.08	6,3	3,85	0,8	40600L		▲	▲		
L406.063.W.02	6,3	3,85	0,2	40600L	▲			▲	▲
L406.063.W.04	6,3	3,85	0,4	40600L	▲			▲	▲
L406.063.W.08	6,3	3,85	0,8	40600L	▲			▲	▲
P	●	○	●	-	-				
M	○	○	●	●	-				
K	●	●	●	-	-				
N	●	○	○	-	●				
S	○	○	●	●	-				
H	-	-	-	-	-				

mit 4 nutzbaren Schneidkanten
with 4 usable cutting edges

präzisionsgeschliffen
precision ground

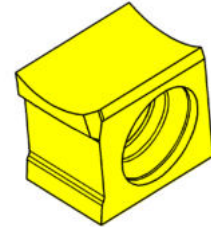
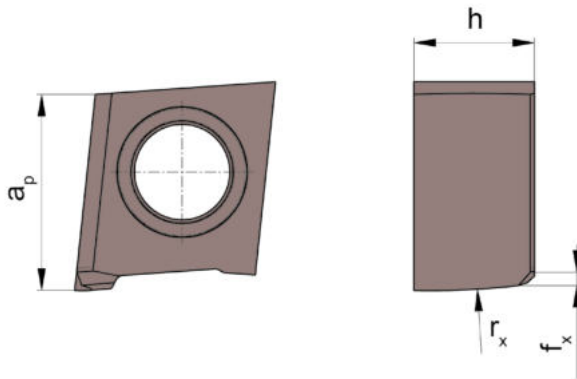
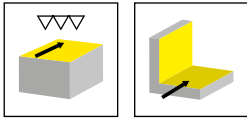

▲ ab Lager
on stock

HM-Sorten
Carbide grades

Δ 4 Wochen
4 weeks

Bestellnummer Part number	a_p	h	r_x	f_x	HIS	AS46	AS4B
R406.063.S.F4	6	3,85	100	0,4	40600R	▲	▲
Breitschlichtschneide, präzisionsgeschliffen Wiper geometry, precision ground						P ●	●
1 nutzbare Schneidkante with 1 usable cutting edge						M ●	●
						K ●	●
						N ●	●
						S ●	●
						H -	-

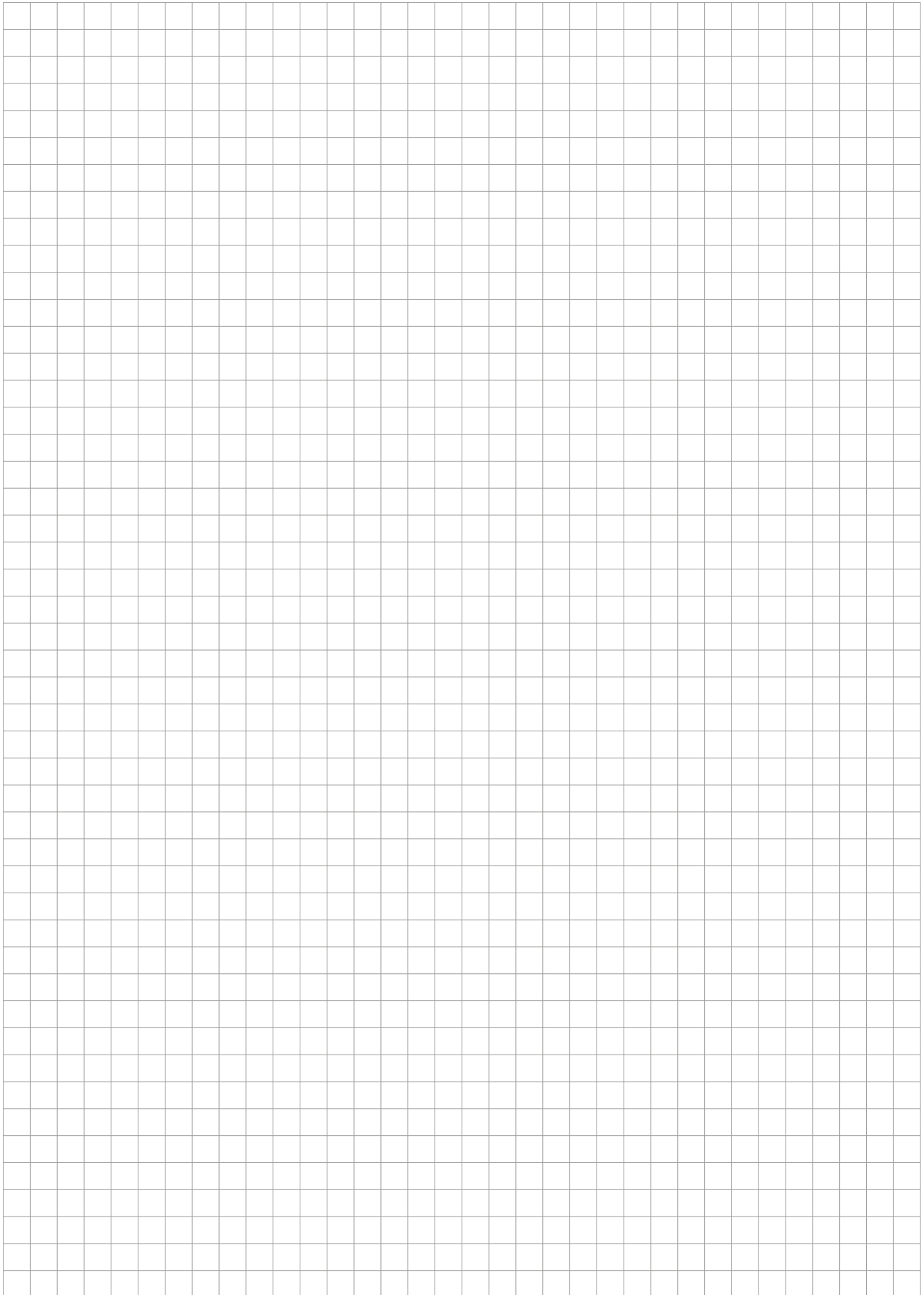

Schafffräser
End Mill
M409

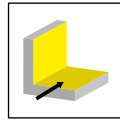

Seite/Page
536-538

Einschraubfräser
Screw-in cutter
M409

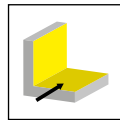

Seite/Page
539

Eckfräser
Shoulder Mill
M409

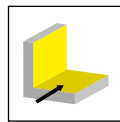

Seite/Page
540-541

Planfräser
Face Mill
M409

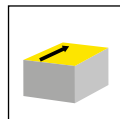

Seite/Page
542-545

Walzenstirnfräser
Shell End Mill
M409

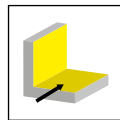

Seite/Page
546

Scheibenfräser
Disc Milling Cutter
M409

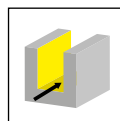

Seite/Page
547

Aufsteckfräser
Arbour Mounted Cutter
M409

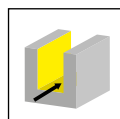

Seite/Page
548

Wendeschneidplatte
Indexable insert
409

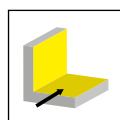

Seite/Page
549

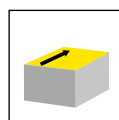

Seite/Page
550

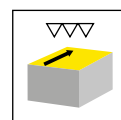

Seite/Page
551

Montageanleitung
Mounting Instructions

Seite/Page
552-557

M409



Tangentialfräsen mit System 409

- 90° Schafffräser
- 90° Einschraubfräser
- Eckfräser
- Planfräser
- Walzenstirnfräser
- Scheibenfräser

Tangential milling with system 409

- 90° End Mill
- 90° Screw-in cutter
- Shoulder Mill
- Face Mill
- Shell End Mill
- Disc Milling Cutter



Abbildung = rechtsschneidend
Picture = right hand cutting version

Bestellnummer Part number	Z	Ds	d	l ₁	l ₂	d ₁	l ₃	a _p	Form	n _{max}	HWS
M409.032.D32.6.04A	4	32	32	111	47	31	60	9,3	A	15600	40900R
M409.040.D32.6.05A	5	40	32	111	47	39	60	9,3	A	13900	40900R

enge Teilung
narrow pitch

Ersatzteile
Spare Parts

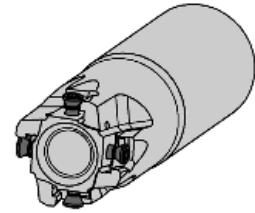
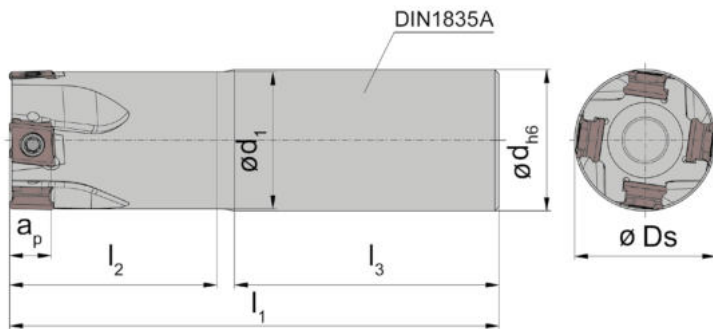
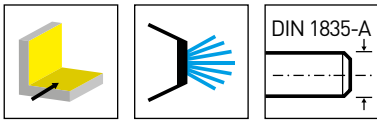
Schaftfräser End Mill	Spannschraube Clamping Screw	TORX PLUS®-Schlüssel TORX PLUS® Wrench
M409...	030.3511.T10P	T10PL



Abbildung = rechtsschneidend
Picture = right hand cutting version

Bestellnummer Part number	Z	Ds	d	l ₁	l ₂	d ₁	l ₃	a _p	Form	n _{max}	HWS
M409.032.D32.6.03B	3	32	32	111	47	31	60	9,3	B	15600	40900R
M409.040.D32.6.04B	4	40	32	111	47	39	60	9,3	B	13900	40900R

enge Teilung
narrow pitch

Ersatzteile
Spare Parts

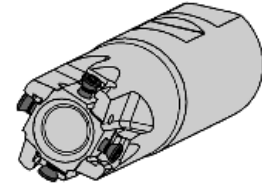
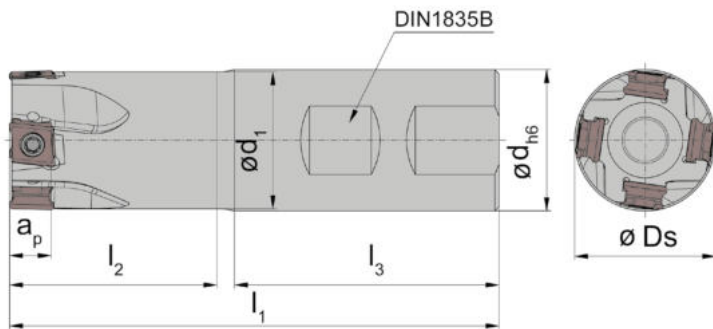
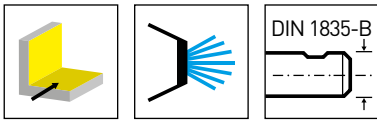
Schaftfräser End Mill	Spannschraube Clamping Screw	TORX PLUS®-Schlüssel TORX PLUS® Wrench
M409...	030.3511.T10P	T10PL



Abbildung = rechtsschneidend
Picture = right hand cutting version

Bestellnummer Part number	Z	Ds	d	l ₁	l ₂	d ₁	l ₃	a _p	Form	n _{max}	HWS
M409.032.D32.6.03B	3	32	32	111	47	31	60	9,3	B	15600	40900R
M409.040.D32.6.04B	4	40	32	111	47	39	60	9,3	B	13900	40900R

weite Teilung
wide pitch

Ersatzteile
Spare Parts

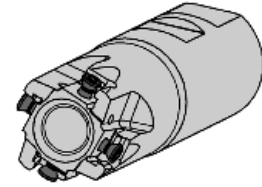
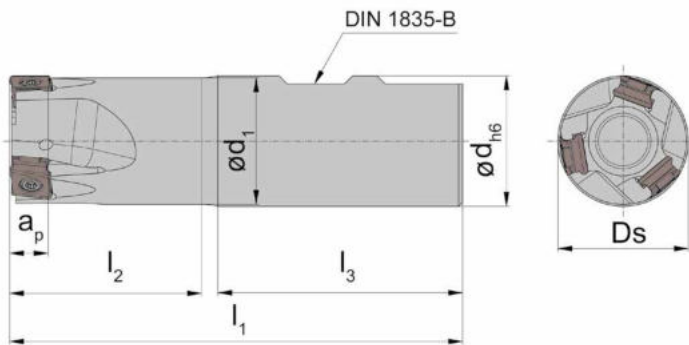
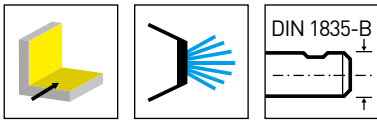
Schaftfräser End Mill	Spannschraube Clamping Screw	TORX PLUS®-Schlüssel TORX PLUS® Wrench
M409...	030.3511.T10P	T10PL



Abbildung = rechtsschneidend
Picture = right hand cutting version

Bestellnummer Part number	Z	Ds	l ₁	l ₂	d ₁	a _p	d ₂	d ₄	SW	n _{max}	HWS	HMS
M409.032.M16.6.03	3	32	66	43	31	9,3	M16	29	24	15600	40900R	16001
M409.032.M16.6.04	4	32	66	43	31	9,3	M16	29	24	15600	40900R	16001
M409.040.M16.6.04	4	40	66	43	39	9,3	M16	29	24	13900	40900R	16001
M409.040.M16.6.05	5	40	66	43	39	9,3	M16	29	24	13900	40900R	16001

Ersatzteile
Spare Parts

Einschraubfräser Screw-in cutter	Spannschraube Clamping Screw	TORX PLUS®-Schlüssel TORX PLUS® Wrench
M409...	030.3511.T10P	T10PL

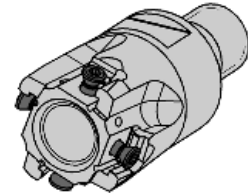
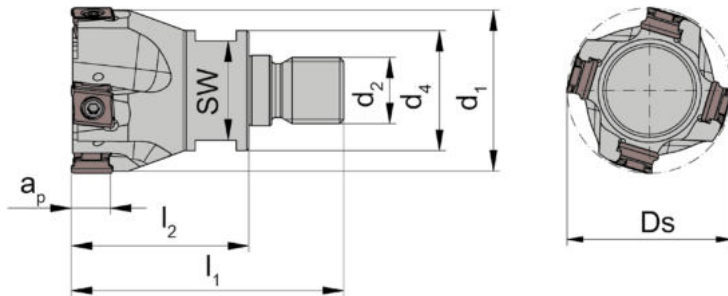

Abbildung = rechtsschneidend
Picture = right hand cutting version

Bestellnummer Part number	Z	Ds	ap	h ₂	h	d ₅	d ₁	d ₂	l ₂	b	C	d _k	n _{max}	HWS
M409.0040.A16.05	5	40	9,3	34,5	35	16	39	16	22	8,4	5,6	33	13900	40900R
M409.0050.A22.07	7	50	9,3	39,5	40	19,5	49	22	24	10,4	6,3	41	12500	40900R
M409.0063.A22.08	8	63	9,3	39,5	40	19,5	62	22	25	10,4	6,3	49	11100	40900R
M409.0063.A27.08	8	63	9,3	39,5	40	23	62	27	27,5	12,4	7	49	11100	40900R
M409.0080.A27.10	10	80	9,3	49,5	50	21,5	79	27	28	12,4	7	59	9800	40900R
M409.0100.A32.12	12	100	9,3	49,5	50	30	99	32	33	14,4	8	80	8800	40900R
M409.0125.A40.16	16	125	9,3	62,5	63	56	124	40	35	16,4	9	89	7900	40900R
M409.0160.A40.20	20	160	9,3	62,5	63	90	159	40	29	16,4	9	110	6900	40900R
M409.0200.A60.24	24	200	9,3	62,5	63	135	199	60	42	25,7	14	130	6200	40900R
M409.0250.A60.30	30	250	9,3	62,5	63	150	249	60	42	25,7	14	160	5500	40900R

bis ø100 mm Aufsteckfräser nach DIN 8030-A, ø125 mm DIN8030-B, ab ø160 mm DIN8030-C
up to ø100 mm arbour mounted cutter as per DIN 8030-A, ø125 DIN8030-B, from ø160 mm DIN 8030-C

ab ø160 mm: Verfügbarkeit und innere Kühlmittelzufuhr auf Anfrage
from ø160 mm: availability and internal coolant upon customers request

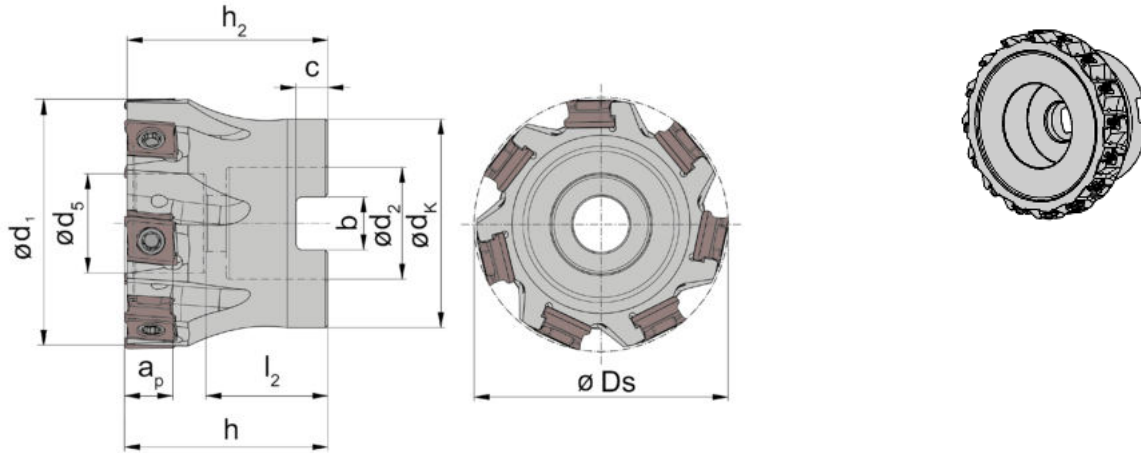
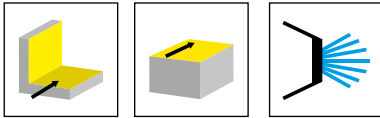
Ersatzteile

Spare Parts

Eckfräser Shoulder Mill	Spannschraube Clamping Screw	TORX PLUS®-Schlüssel TORX PLUS® Wrench	Fräseranzugsschraube Tightening Bolt
M409....	030.3511.T10P	T10PL	
M409.0...A40..	030.3511.T10P	T10PL	20.30.6367
M409.0...A60..	030.3511.T10P	T10PL	30.45.6367



Abbildung = rechtsschneidend
Picture = right hand cutting version

Bestellnummer Part number	Z	Ds	ap	h ₂	h	d ₅	d ₁	d ₂	l ₂	b	C	d _k	n _{max}	HWS
M409.0040.A16.04	4	40	9,3	34,5	35	16	39	16	22	8,4	5,6	33	13900	40900R
M409.0050.A22.05	5	50	9,3	39,5	40	19,5	49	22	24	10,4	6,3	41	12500	40900R
M409.0063.A22.06	6	63	9,3	39,5	40	19,5	62	22	25	10,4	6,3	49	11100	40900R
M409.0063.A27.06	6	63	9,3	39,5	40	23	62	27	27,5	12,4	7	49	11100	40900R
M409.0080.A27.07	7	80	9,3	49,5	50	21,5	79	27	28	12,4	7	59	9800	40900R
M409.0100.A32.08	8	100	9,3	49,5	50	30	99	32	33	14,4	8	80	8800	40900R
M409.0125.A40.10	10	125	9,3	62,5	63	56	124	40	35	16,4	9	89	7900	40900R
M409.0160.A40.14	14	160	9,3	62,5	63	90	159	40	29	16,4	9	110	6900	40900R
M409.0200.A60.16	16	200	9,3	62,5	63	135	199	60	42	25,7	14	130	6200	40900R
M409.0250.A60.20	20	250	9,3	62,5	63	150	249	60	42	25,7	14	160	5500	40900R

bis ø100 mm Aufsteckfräser nach DIN 8030-A, ø125 mm DIN8030-B, ab ø160 mm DIN8030-C
up to ø100 mm arbour mounted cutter as per DIN 8030-A, ø125 DIN8030-B, from ø160 mm DIN 8030-C

ab ø160 mm: Verfügbarkeit und innere Kühlmittelzufuhr auf Anfrage
from ø160 mm: availability and internal coolant upon customers request

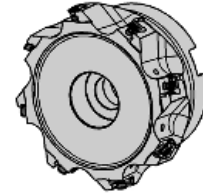
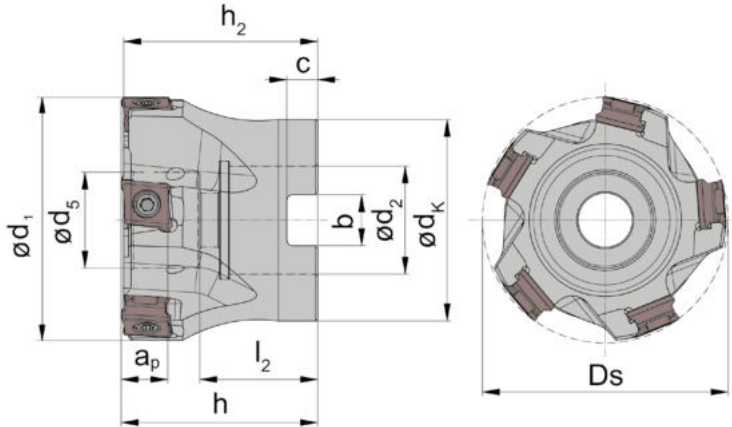
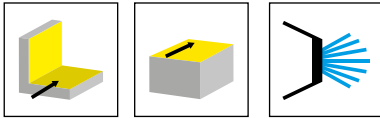
Ersatzteile

Spare Parts

Eckfräser Shoulder Mill	Spannschraube Clamping Screw	TORX PLUS®-Schlüssel TORX PLUS® Wrench	Fräseranzugsschraube Tightening Bolt
M409....	030.3511.T10P	T10PL	
M409.0...A40..	030.3511.T10P	T10PL	20.30.6367
M409.0...A60..	030.3511.T10P	T10PL	30.45.6367



Abbildung = rechtsschneidend
Picture = right hand cutting version

Bestellnummer Part number	Z	Ds	ap	h ₂	h	d ₅	d ₁	d ₂	l ₂	b	C	d _k	n _{max}	HWS
M409.0040.A16.45.05	5	40	6,2	32,5	35	16	55	16	22	8,4	5,6	33	13900	40900R
M409.0050.A22.45.07	7	50	6,2	37,5	40	19,5	67	22	24	10,4	6,3	41	12500	40900R
M409.0063.A22.45.08	8	63	6,2	37,5	40	19,5	80	22	25	10,4	6,3	49	11100	40900R
M409.0063.A27.45.08	8	63	6,2	37,5	40	22	79	27	27,5	12,4	7	49	11100	40900R
M409.0080.A27.45.10	10	80	6,2	47,5	50	22	96	27	27,5	12,4	7	59	9800	40900R
M409.0125.A40.45.16	16	125	6,2	60,5	63	56	141	40	35	16,4	9	89	7900	40900R
M409.0160.A40.45.20	20	160	6,2	60,5	63	90	176	40	29	16,4	9	110	6900	40900R
M409.0200.A60.45.24	24	200	6,2	60,5	63	135	216	60	42	25,7	14	130	6200	40900R
M409.0250.A60.45.30	30	250	6,2	60,5	63	150	266	60	42	25,7	14	160	5500	40900R

bis ø100 mm Aufsteckfräser nach DIN 8030-A, ø125 mm DIN8030-B, ab ø160 mm DIN8030-C
up to ø100 mm arbour mounted cutter as per DIN 8030-A, ø125 mm DIN8030-B, from ø160 mm DIN 8030-C

ap= 6,2 mm bei rx= 0,8 mm
ap = 6,2 mm can be reached with rx = 0,8 mm

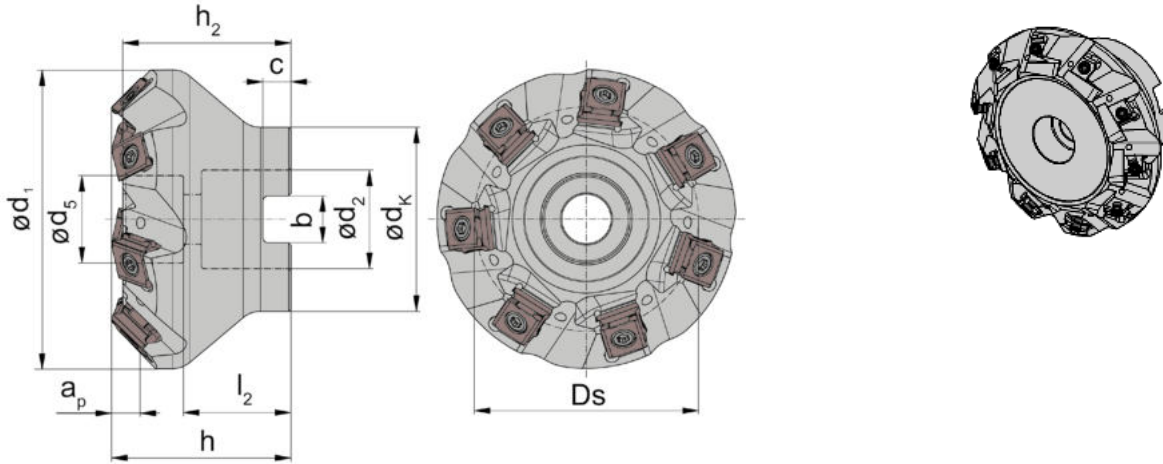
ab ø160 mm: Verfügbarkeit und innere Kühlmittelzufuhr auf Anfrage
from ø160 mm: availability and internal coolant upon customers request

Ersatzteile
Spare Parts

Planfräser Face Mill	Spannschraube Clamping Screw	TORX PLUS®-Schlüssel TORX PLUS® Wrench	Fräseranzugsschraube Tightening Bolt
M409....	030.3511.T10P	T10PL	
M409.0...A40..	030.3511.T10P	T10PL	20.30.6367
M409.0...A60..	030.3511.T10P	T10PL	30.45.6367



Abbildung = rechtsschneidend
Picture = right hand cutting version

Bestellnummer Part number	Z	Ds	ap	h ₂	h	d ₅	d ₁	d ₂	l ₂	b	C	d _k	n _{max}	HWS
M409.0040.A16.45.04	4	40	6,2	32,5	35	17	55	16	18	8,4	5,6	33	13900	40900R
M409.0050.A22.45.05	5	50	6,2	37,5	40	20	67	22	20	10,4	6,3	41	12500	40900R
M409.0063.A22.45.06	6	63	6,2	37,5	40	20	79	22	20	10,4	6,3	49	11100	40900R
M409.0080.A27.45.07	7	80	6,2	47,5	50	22	96	27	27,5	12,4	7	59	9800	40900R
M409.0100.A32.45.08	8	100	6,2	47,5	50	30	116	32	32,5	14,4	8	80	8800	40900R
M409.0160.A40.45.14	14	160	6,2	60,5	63	90	176	40	29	16,4	9	110	6900	40900R
M409.0200.A60.45.16	16	200	6,2	60,5	63	135	216	40	42	25,7	14	130	6200	40900R

bis ø100 mm Aufsteckfräser nach DIN 8030-A, ø125 mm DIN8030-B, ab ø160 mm DIN8030-C
up to ø100 mm arbour mounted cutter as per DIN 8030-A, ø125 DIN8030-B, from ø160 mm DIN 8030-C

ap= 6,2 mm bei rx= 0,8 mm
ap = 6,2 mm can be reached with rx = 0,8 mm

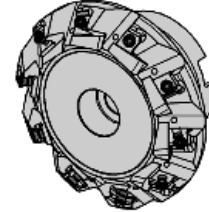
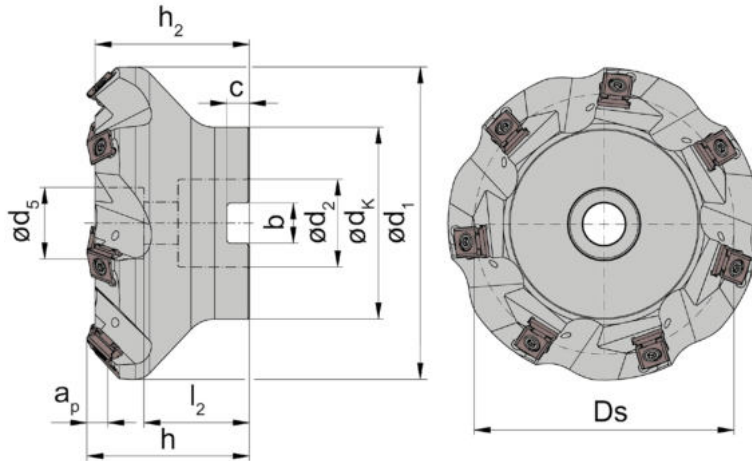
ab ø160 mm: Verfügbarkeit und innere Kühlmittelzufuhr auf Anfrage
from ø160 mm: availability and internal coolant upon customers request

Ersatzteile

Spare Parts

Planfräser Face Mill	Spannschraube Clamping Screw	TORX PLUS®-Schlüssel TORX PLUS® Wrench	Fräseranzugsschraube Tightening Bolt
M409....	030.3511.T10P	T10PL	
M409.0160.A40.45.14	030.3511.T10P	T10PL	20.30.6367
M409.0200.A60.45.16	030.3511.T10P	T10PL	30.45.6367



Abbildung = rechtsschneidend
Picture = right hand cutting version

Bestellnummer Part number	Z	Ds	ap	h ₂	h	d ₅	d ₁	d ₂	b	C	d _k	n _{max}	HWS
M409.0040.A16.60.05	5	40	7,7	32,5	35	16	50	16	8,4	5,6	33	13900	40900R
M409.0050.A22.60.07	7	50	7,7	37,5	40	19,5	63	22	10,4	6,3	41	12500	40900R
M409.0063.A22.60.08	8	63	7,7	37,5	40	19,5	73	22	10,4	6,3	49	11100	40900R
M409.0063.A27.60.08	8	63	7,7	37,5	40	19,5	75	27	12,4	7	49	11100	40900R
M409.0100.A32.60.12	12	100	7,7	47,5	50	22	112	32	14,4	8	59	8800	40900R
M409.0160.A40.60.20	20	160	7,7	60,5	63	90	172	40	16,4	9	110	6900	40900R
M409.0200.A60.60.24	24	200	7,7	60,5	63	135	212	60	25,7	14	130	6200	40900R
M409.0250.A60.60.30	30	250	7,7	60,5	63	150	262	60	25,7	14	160	5500	40900R

bis ø100 mm Aufsteckfräser nach DIN 8030-A, ø125 mm DIN8030-B, ab ø160 mm DIN8030-C
up to ø100 mm arbour mounted cutter as per DIN 8030-A, ø125 mm DIN8030-B, from ø160 mm DIN 8030-C

ap = 7,7 mm bei rx = 0,8 mm
ap = 7,7 mm can be reached with rx = 0,8 mm

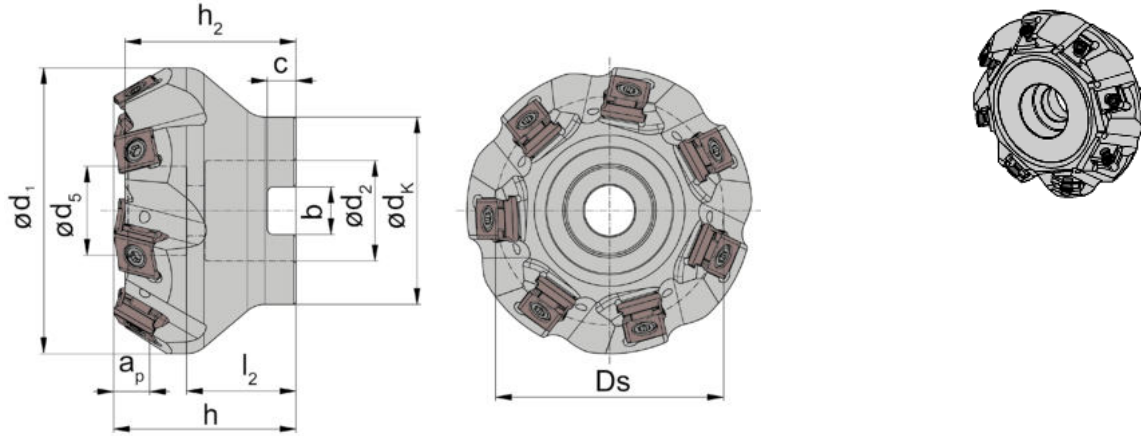
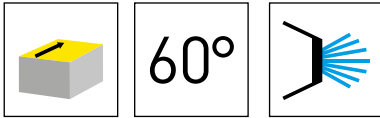
ab ø160 mm: Verfügbarkeit und innere Kühlmittelzufuhr auf Anfrage
from ø160 mm: availability and internal coolant upon customers request

Ersatzteile

Spare Parts

Planfräser Face Mill	Spannschraube Clamping Screw	TORX PLUS®-Schlüssel TORX PLUS® Wrench	Fräseranzugsschraube Tightening Bolt
M409....	030.3511.T10P	T10PL	
M409.0160.A40.60.20	030.3511.T10P	T10PL	20.30.6367
M409.02...	030.3511.T10P	T10PL	30.45.6367



Abbildung = rechtsschneidend
Picture = right hand cutting version

Bestellnummer Part number	Z	Ds	ap	h ₂	h	d ₅	d ₁	d ₂	b	C	d _k	n _{max}	HWS
M409.0040.A16.60.04	4	40	7,7	32,5	35	17	52	16	8,4	5,6	33	13900	40900R
M409.0050.A22.60.05	5	50	7,7	37,5	40	20	62	22	10,4	6,3	41	12500	40900R
M409.0100.A32.60.08	8	100	7,7	47,5	50	30	112	32	14,4	8	80	8800	40900R
M409.0125.A40.60.10	10	125	7,7	60,5	63	56	137	40	16,4	9	89	7900	40900R
M409.0160.A40.60.14	14	160	7,7	60,5	63	90	172	40	16,4	9	110	6900	40900R
M409.0200.A60.60.16	16	200	7,7	60,5	63	135	212	60	25,7	14	130	6200	40900R
M409.0250.A60.60.20	20	250	7,7	60,5	63	150	262	60	25,7	14	160	5500	40900R

bis ø100 mm Aufsteckfräser nach DIN 8030-A, ø125 mm DIN8030-B, ab ø160 mm DIN8030-C
up to ø100 mm arbour mounted cutter as per DIN 8030-A, ø125 mm DIN8030-B, from ø160 mm DIN 8030-C

ap = 7,7 mm bei rx = 0,8 mm
ap = 7,7 mm can be reached with rx = 0,8 mm

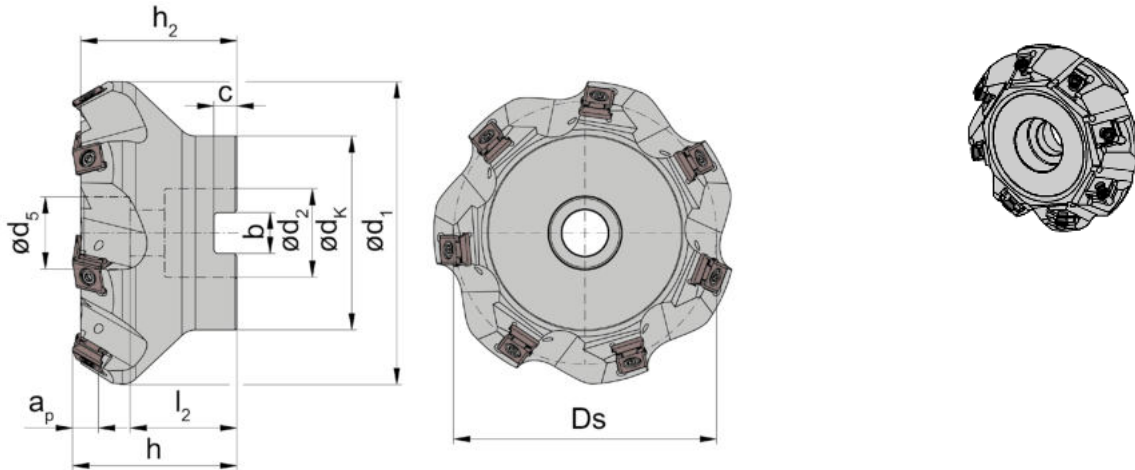
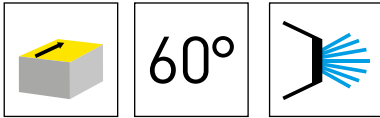
ab ø160 mm: Verfügbarkeit und innere Kühlmittelzufuhr auf Anfrage
from ø160 mm: availability and internal coolant upon customers request

Ersatzteile

Spare Parts

Planfräser Face Mill	Spannschraube Clamping Screw	TORX PLUS®-Schlüssel TORX PLUS® Wrench	Fräseranzugsschraube Tightening Bolt
M409....	030.3511.T10P	T10PL	
M409.0125.../...160...	030.3511.T10P	T10PL	20.30.6367
M409.02...	030.3511.T10P	T10PL	30.45.6367



Abbildung = rechtsschneidend
Picture = right hand cutting version

Bestellnummer Part number	Z	Z _{eff}	Ds	a _p	h ₂	h	d _s	d ₂	l ₂	b	C	d _k	n _{max}	HWS
M409.0040.A16.W.10	10	2	40	43,2	64,5	65	16	16	53,4	8,4	5,6	39	13900	40900R
M409.0050.A22.W.15	15	3	50	43,2	64,5	65	19,5	22	49	10,4	6,3	49	12500	40900R
M409.0063.A27.W.20	20	4	63	43,2	64,5	65	21,5	27	48,8	12,4	7	62	11100	40900R

Wendeschneidplatte R409.093.U.08 ist bevorzugt zu verwenden.
Indexable insert R409.093.U.08 is preferred to use.

Ersatzteile

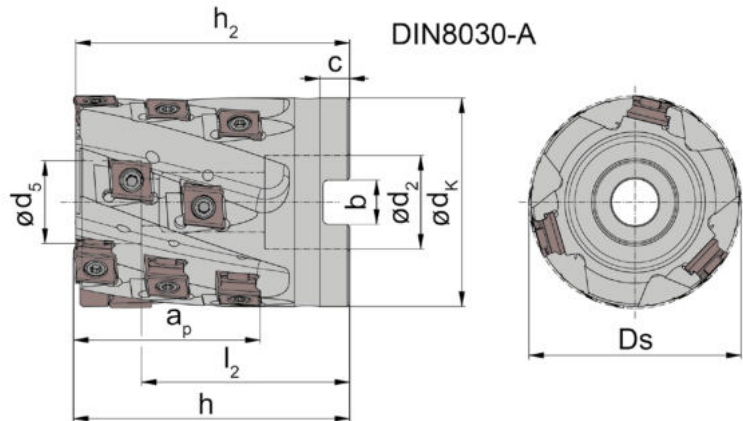
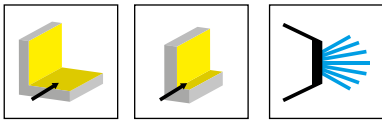
Spare Parts

Walzenstirnfräser Shell End Mill	Spannschraube Clamping Screw	TORX PLUS®-Schlüssel TORX PLUS® Wrench
M409...	030.3511.T10P	T10PL



Abbildung = rechtsschneidend
Picture = right hand cutting version

Bestellnummer Part number	Z	Z _{eff}	D _s	t _{max}	d ₂	b ₂	w	n _{max}	rechte WSP right hand insert	linke WSP left hand insert	HWS
M409.0100.32.S.14	10	5	100	26	32	14,4	14	8800	5x R409.093.U.08	5x L409.093.U.08	40900R • 40900L
M409.0100.32.S.18	10	5	100	26	32	18,4	18	8800	5x R409.093.U.08	5x L409.093.U.08	40900R • 40900L
M409.0125.40.S.14	12	6	125	34,5	40	14,4	14	7900	6x R409.093...	6x L409.093...	40900R • 40900L
M409.0125.40.S.18	12	6	125	34,5	40	18,4	18	7900	6x R409.093...	6x L409.093...	40900R • 40900L

Ersatzteile

Spare Parts

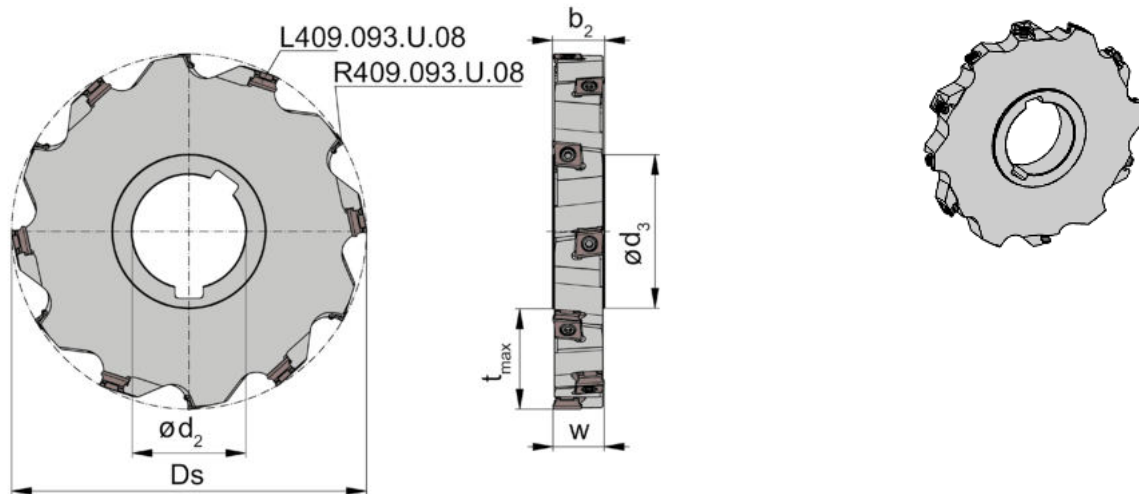
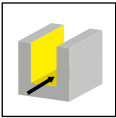
Scheibenfräser Disc Milling Cutter	Spannschraube Clamping Screw	TORX PLUS®-Schlüssel TORX PLUS® Wrench
M409...	030.3511.T10P	T10PL

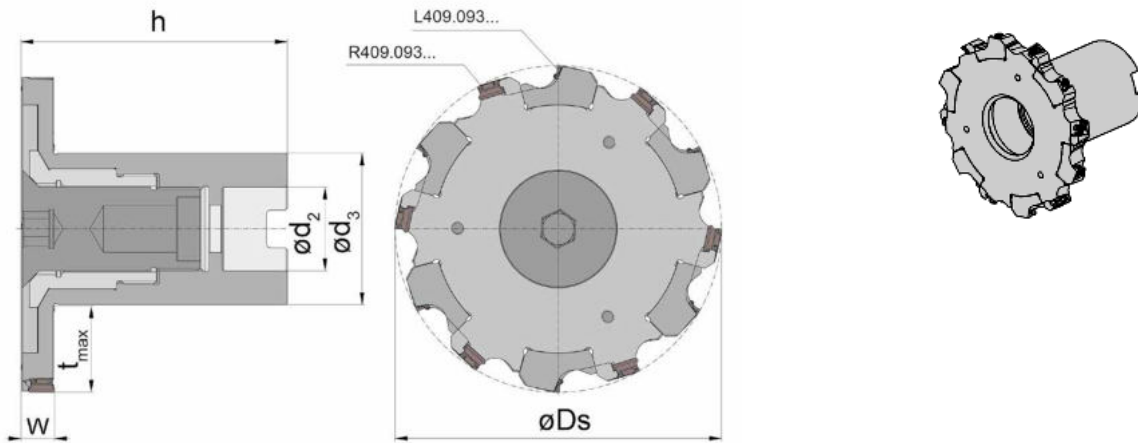
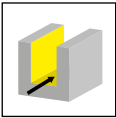

Bestellnummer Part number	Z	Z _{eff}	Ds	t _{max}	h _{min}	h _{max}	d ₃	d ₂	w _{min}	w _{max}	rechte WSP right hand insert	linke WSP left hand insert	HWS
M409.0125.A32.ES.129	12	6	125	32,5	102	107,9	58	32	12,9	18,8	6x R409.093...	6x L409.093...	40900R • 40900L

Aufsteckfräser einstellbar!
Arbour mounted cutter is adjustable!

Ersatzteile
Spare Parts

Aufsteckfräser Arbour Mounted Cutter	Schraube Screw	Spannschraube Clamping Screw	TORX PLUS®-Schlüssel TORX PLUS® Wrench	Verstelladapter Adjustment Adapter
M409.0125.A32.ES.129	C409.0125.A32.ES.129	030.3511.T10P	T10PL	A409.0125.A32.ES.129

Wendeschnidplatte

Indexable insert

409

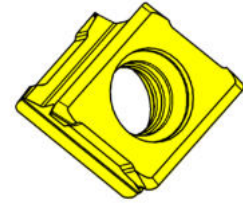
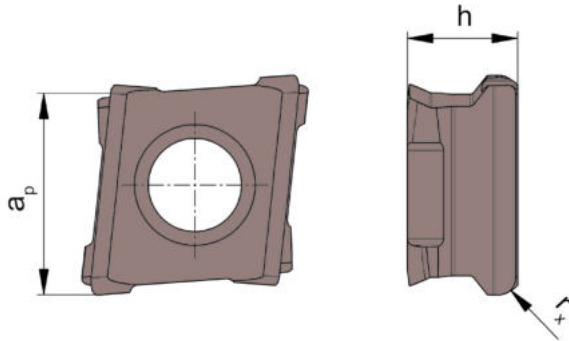
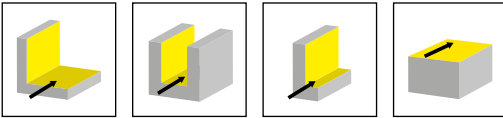

HM-Sorten
Carbide grades

▲ ab Lager
on stock

△ 4 Wochen
4 weeks

Bestellnummer Part number	a _p	h	r _x	HIS	K10	AS46	AS4B	IG35	NE2B
R409.093.U.02	9,3	5,2	0,2	40900R		△	▲		
R409.093.U.04	9,3	5,2	0,4	40900R		▲	▲		
R409.093.U.08	9,3	5,2	0,8	40900R		▲	▲		
R409.093.U.12	9,3	5,2	1,2	40900R		▲	▲		
R409.093.W.02	9,3	5,2	0,2	40900R	▲			▲	▲
R409.093.W.04	9,3	5,2	0,4	40900R	▲			▲	▲
R409.093.W.08	9,3	5,2	0,8	40900R	▲			▲	▲
R409.093.W.12	9,3	5,2	1,2	40900R				▲	▲
L409.093.U.02	9,3	5,2	0,2	40900L		△	▲		
L409.093.U.04	9,3	5,2	0,4	40900L		▲	▲		
L409.093.U.08	9,3	5,2	0,8	40900L		▲	▲		
L409.093.U.12	9,3	5,2	1,2	40900L			▲		
L409.093.W.02	9,3	5,2	0,2	40900L	▲			▲	▲
L409.093.W.04	9,3	5,2	0,4	40900L	▲			▲	▲
L409.093.W.08	9,3	5,2	0,8	40900L	▲			▲	▲
L409.093.W.12	9,3	5,2	1,2	40900L				▲	△
P	●	○	●	-	-				
M	○	○	●	●	-				
K	●	●	●	-	-				
N	●	○	○	-	●				
S	○	○	●	●	-				
H	-	-	-	-	-				

mit 4 nutzbaren Schneidkanten
with 4 usable cutting edges

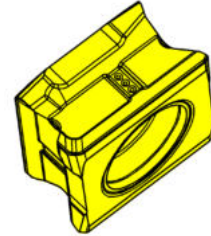
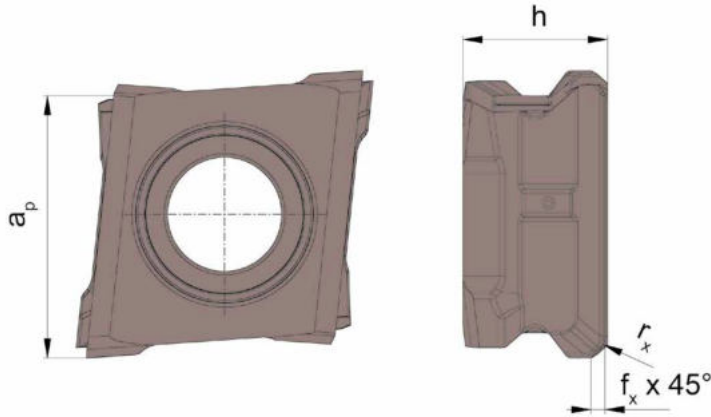
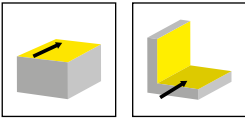

HM-Sorten
Carbide grades
▲ ab Lager
on stock
△ 4 Wochen
4 weeks

Bestellnummer Part number	a_p	h	r_x	f_x	HIS	AS45	AS46
RS409.090.P.F05	9	5,2	0,6	0,5	40900R	▲	▲
LS409.090.P.F05	9	5,2	0,6	0,5	40900L	▲	▲

mit 4 nutzbaren Schneidkanten
with 4 usable cutting edges

P	●	○
M	●	○
K	●	●
N	○	○
S	●	○
H	-	-

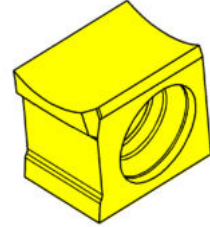
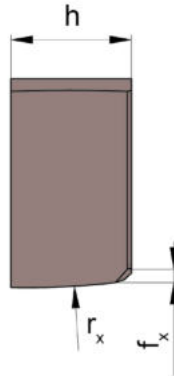
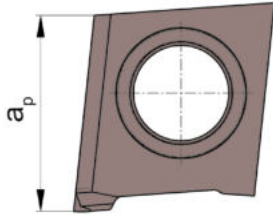
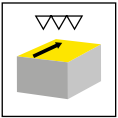

▲ ab Lager
on stock

HM-Sorten
Carbide grades

Δ 4 Wochen
4 weeks

Bestellnummer Part number	a_p	h	r_x	f_x	HIS	AS46	AS4B
R409.093.S.F4	9,3	5,2	100	0,4	40900R	▲	▲
Breitschlichtschneide, präzisionsgeschliffen Wiper geometry, precision ground						P ●	●
1 nutzbare Schneidkante with 1 usable cutting edge						M ●	●
						K ●	●
						N ○	○
						S ○	○
						H -	-

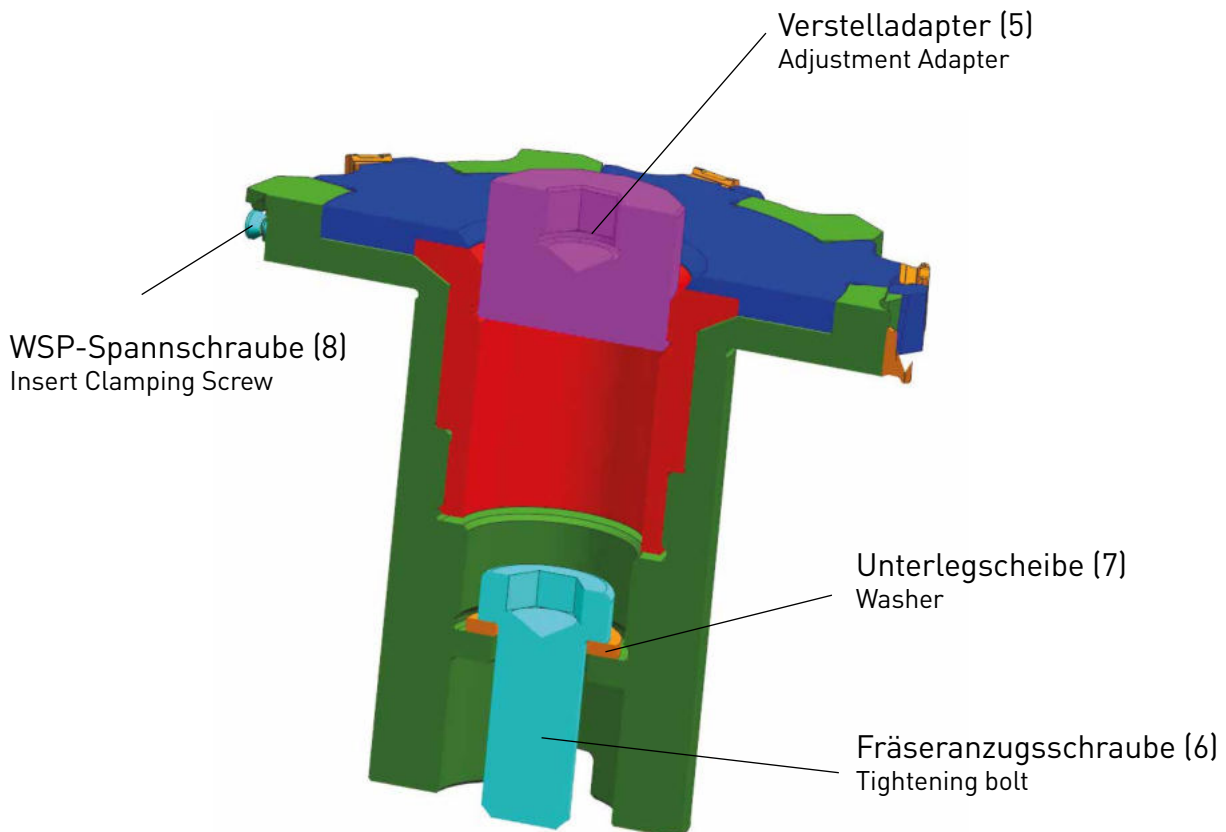
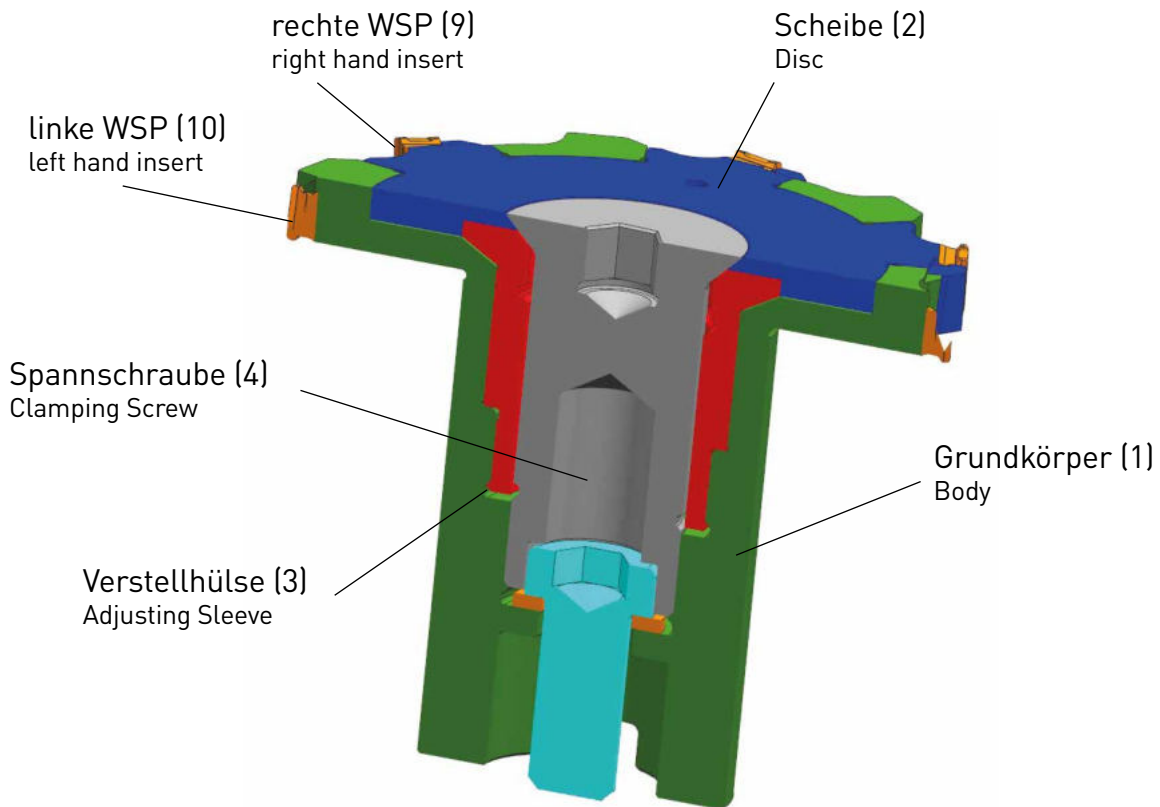

1. Montage der Wendeschneidplatten mittels WSP-Spannschraube (8);
[rechte WSP (9) und linke WSP (10) Ausführung]

Mount the indexable insert using clamping screw (8);
[right-hand insert (9) and left-hand insert (10) version]

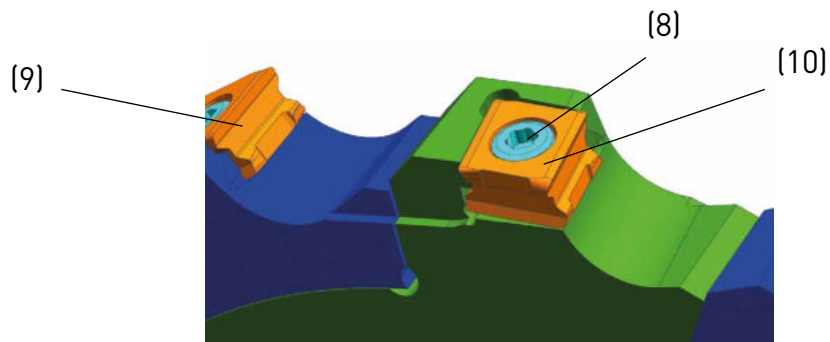

2. Spannschraube (4) lösen und heraus drehen
Loosen the clamping screw (4) and twist it out

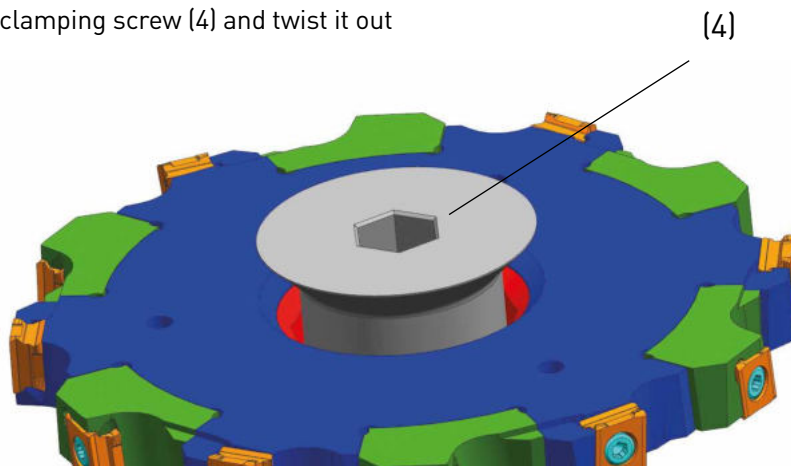

3. Fräs Werkzeug mit beigelegter Unterscheibe (7) und Fräseranzugschraube (6) auf die Werkzeugaufnahme (nicht abgebildet) montieren

Mount the milling tool with the enclosed washer (7) and cutter tightening bolt (6) on the toolholder (not shown)

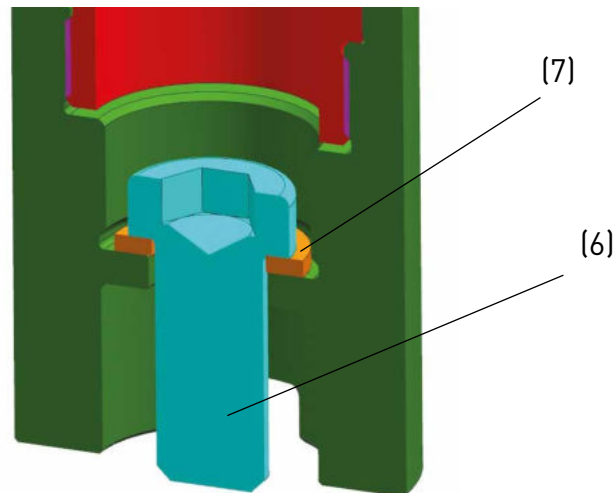

4. Schneidbreite des Fräses mithilfe des Verstelladapters (5) auf das geforderte Maß voreinstellen

Pre-set the cutting width of the milling cutter to the required dimension with the aid of the adjustment adapter (5)

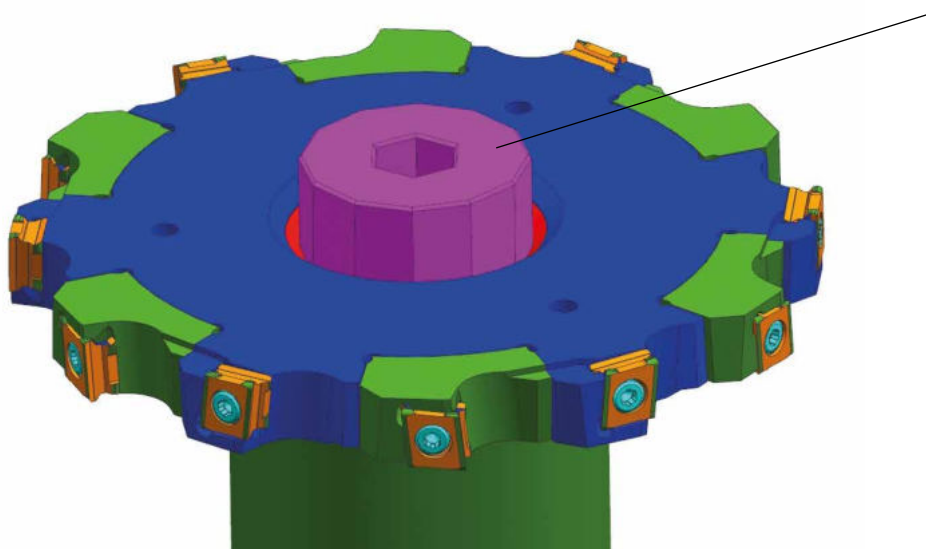

Einstellung auf einem Werkzeugvoreinstellgerät:

- Montiertes Werkzeug in die Adaption des Voreinstellgerätes einsetzen
- Sicher stellen, dass das Mindestmaß (System 409 → 12,9 mm; System 406 → 9,6 mm) des Werkzeugs eingestellt ist.

Anmerkung: Verstellhülse (3) ist auf Anschlag eingedreht

Adjustment on a tool presetter:

- Insert the mounted tool into the adapter of the presetter.
- Ensure the minimum dimension (system 409 → 12.9 mm; System 406 → 9.6 mm) of the tool.

Note: Adjusting sleeve (3) is tightened fully

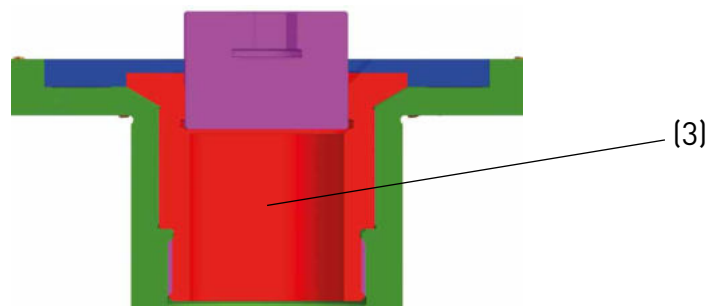

- Untere Schneidenreihe ausmessen [linke WSP's (9)]
 - Obere Schneidenreihe ausmessen [rechte WSP's (10)]
- Measure the lower cutting edge row [left hand inserts (9)]
 - Measure the upper cutting edge row [right hand inserts (10)]

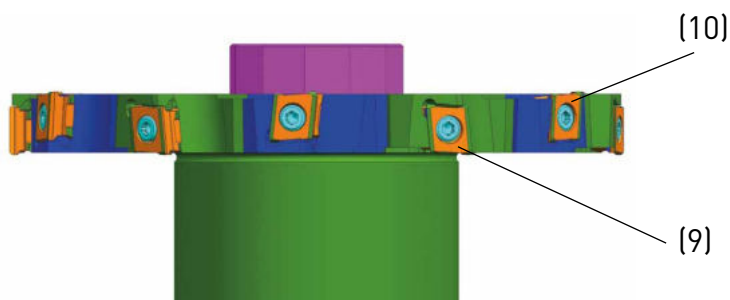

- e. Mittels des Verstelladapters (5) die Schneidbreite justieren (axiale Verstellung je Umdrehung entspricht 1,5 mm)
- e. Adjust the cutting width by means of the adjustment adapter (5) (axial adjustment for each turn corresponds to 1.5 mm)

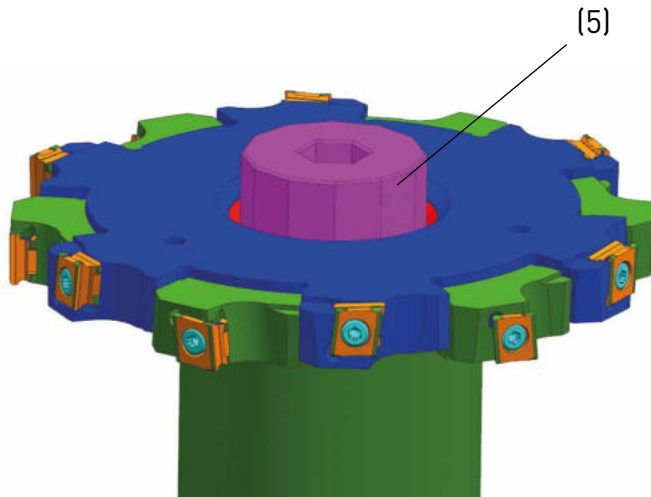

- f. Spannschraube (4) eindrehen und festziehen
- f. Screw in and tighten the clamping screw (4)

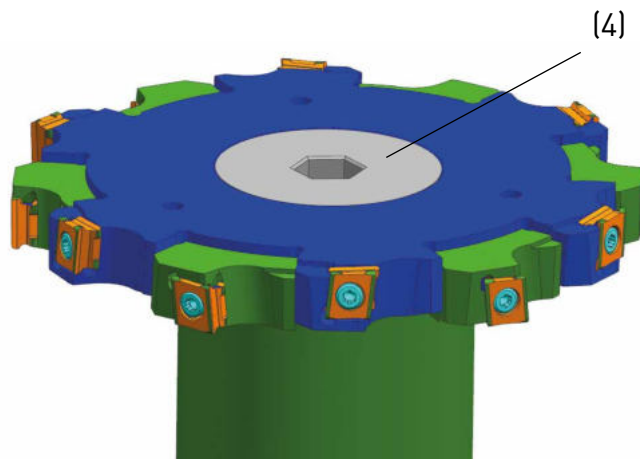

Hinweis:

- 1) Nach der ersten gefertigten Nut ist diese zu messen bzw. zu prüfen. Eine Korrektur der Schneidbreite des Fräswerkzeugs ist gegebenenfalls vorzunehmen.
- 2) Grundsätzlich ist bei der Montage und Demontage auf Sauberkeit der einzelnen Teile zu achten.
- 3) Empfehlenswert ist das Schmieren bzw. Fetten der Lauf- und Gewindeflächen des Einstellmechanismus.
- 4) Die maximale Schneidbreite beachten:
System 409 → 18,8 mm; System 406 → 12,9 mm

Note:

- 1) After the first groove has been machined, it must be measured or checked. If necessary, the cutting width of the milling tool must be corrected.
- 2) The individual parts must be kept clean during assembly and disassembly
- 3) We recommend lubricating or greasing the contact and thread surfaces of the adjustment mechanism.
- 4) Observe the maximum cutting width:
System 409 → 18.8 mm; System 406 → 12.9 mm

Eckfräser
Shoulder Mill
M610

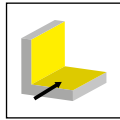

Seite/Page
560

Aufsteckfräser
Arbour Mounted Cutter
M610

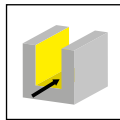

Seite/Page
561

Wendeschneidplatte
Indexable insert
610

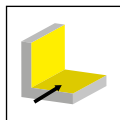

Seite/Page
562

M610



**Tangentialfräsen
mit System 610**

Schneidkreis-Ø 100-125 mm

**Tangential milling
with system 610**

cutting edge Ø 100-125 mm

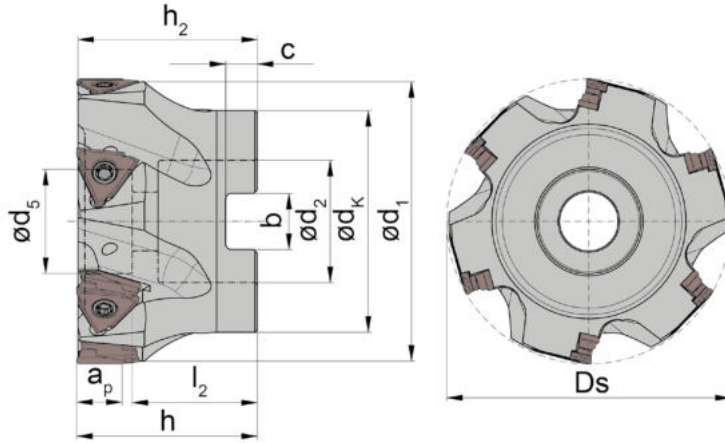
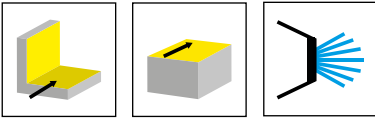

Bestellnummer Part number	Z	Ds	ap	h ₂	h	d ₅	d ₁	d ₂	l ₂	b	C	d _k	n _{max}	HWS
M610.0050.A22.05	5	50	9,9	39,7	40	19,5	49	22	24	10,4	6,3	41	10000	61000R
M610.0063.A22.06	6	63	9,9	39,7	40	19,5	62	22	25	10,4	6,3	49	9000	61000R
M610.0063.A27.06	6	63	9,9	39,7	40	23	62	27	27,5	12,4	7	49	9000	61000R
M610.0080.A27.08	8	80	9,9	49,7	50	21,5	79	27	28	12,4	7	59	8000	61000R
M610.0100.A32.10	10	100	9,9	49,7	50	30	99	32	33	14,4	8	80	7000	61000R
M610.0125.A40.12	12	125	9,9	62,7	63	56	124	40	35	16,4	9	89	6000	61000R

Ersatzteile
Spare Parts

Eckfräser Shoulder Mill	Spannschraube Clamping Screw	TORX PLUS®-Schlüssel TORX PLUS® Wrench	Fräseranzugsschraube Tightening Bolt
M610....	030.3513.T15P	T15PQ	
M610.0125.A40.12	030.3513.T15P	T15PQ	20.30.6367

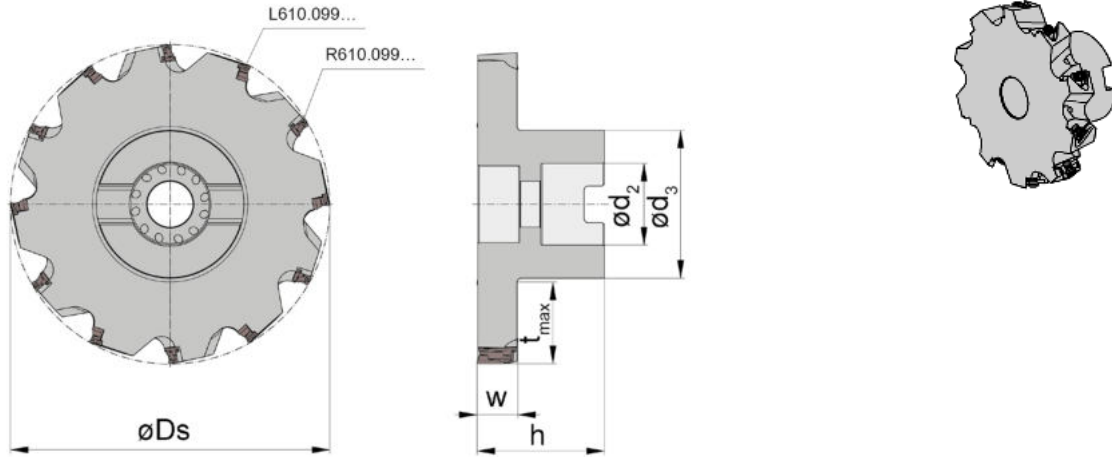
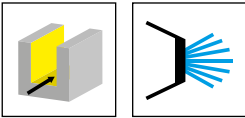

Bestellnummer Part number	Z	Z _{eff}	Ds	t _{max}	h	d ₃	d ₂	n _{max}	w	rechte WSP right hand insert	linke WSP left hand insert	HWS
M610.0125.A32.S.16	12	6	125	32,5	50	58	32	6000	16	6x R610.099.U....	6x L610.099.U....	61000L

Ersatzteile

Spare Parts

Aufsteckfräser Arbour Mounted Cutter	Spannschraube Clamping Screw	TORX PLUS®-Schlüssel TORX PLUS® Wrench
M610.0125.A32.S.16	030.3513.T15P	T15PQ

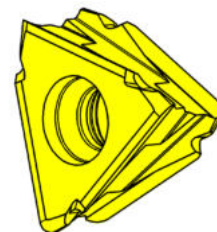
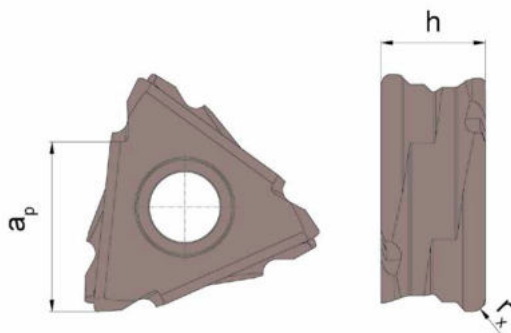
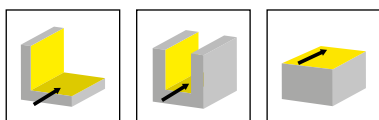

HM-Sorten
Carbide grades

▲ ab Lager
on stock

△ 4 Wochen
4 weeks

Bestellnummer Part number	a_p	h	r_x	HIS	AS46	AS4B	IG35	NE2B
R610.099.U.04	9,9	6,2	0,4	61000R	▲	▲		
R610.099.W.04	9,9	6,2	0,4	61000R			▲	△
R610.099.W.08	9,9	6,2	0,8	61000R			▲	△
L610.099.U.04	9,9	6,2	0,4	61000L	△	▲		
L610.099.W.04	9,9	6,2	0,4	61000L			△	△
L610.099.W.08	9,9	6,2	0,8	61000L			△	△
P	o	●	-	-				
M	o	●	●	-				
K	●	●	-	-				
N	o	o	-	●				
S	o	●	●	-				
H	-	-	-	-				

Mittlere Spandicke h_m zur Ermittlung des Vorschubs

Medium chip thickness h_m for calculating the feed rate

ISO	406 / 409	610
	h_m (mm)	h_m (mm)
P	0,08 - 0,14	0,08 - 0,10
M	0,07- 0,09	0,04 - 0,06
K	0,12 - 0,16	0,09 - 0,11
N	0,1 - 0,12	0,06 - 0,08
S	0,06 - 0,09	0,04 - 0,06

$$f_z = (h_m \times \pi \times d_e \times \phi_s) / (360^\circ \times a_e) \text{ [vereinfacht } f_z = h_m \times \sqrt{d_e/a_e} \text{ bei } a_e/d_e < 0,3]$$

$$f_z = (h_m \times \pi \times d_e \times \phi_s) / (360^\circ \times a_e) \text{ [simplified } f_z = h_m \times \sqrt{d_e/a_e} \text{ with } a_e/d_e < 0,3]$$

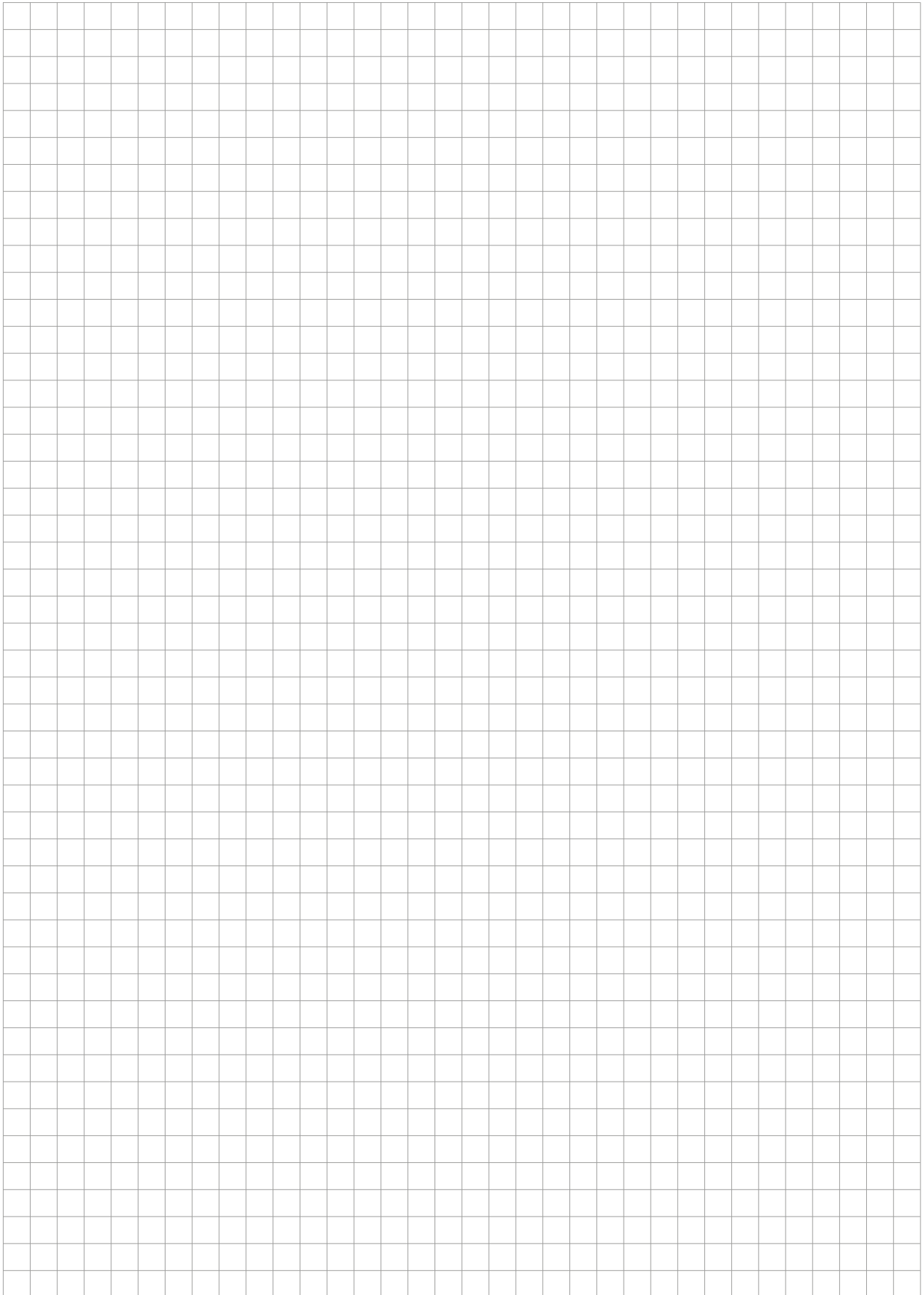

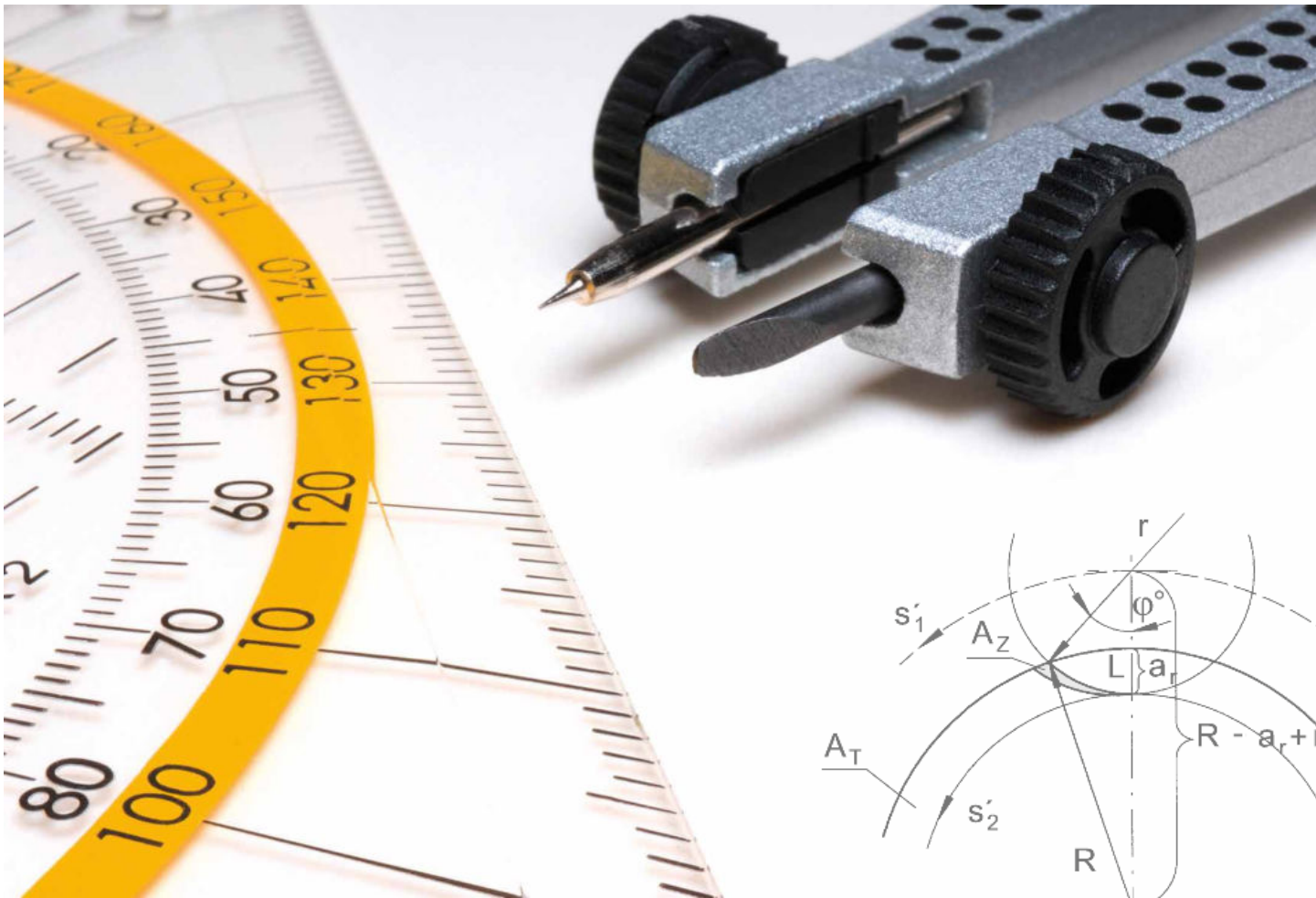

Inhalt/Summary	Seite/Page
Anzugsmomente Torque Specification	566 - 568
Technische Hinweise Technical Instructions	569 - 570
Formelzeichen Cutting Data	571
Schnittdaten Cutting Data	572 - 577
Beschichtungsübersicht Coating Overview	578 - 579

Nachstehende Drehmomente sind für die Spannschrauben zulässig. Wir empfehlen keine zusätzlichen Gleitmittel wie Kupferpaste oder ähnliches für die Schrauben zu verwenden.

Following torques are allowed for screws of inserts. We do not recommend using any additional lubricants such as copper paste or similar for the screws.

Typ Type	Schraube Screw	M_d Nm	Schlüssel Clamping wrench	Klinge Blade
380	5.12T20P	6,50	T20PQ	DT20PK / DT20PQ
381	5.12T20P	6,50	T20PQ	DT20PK / DT20PQ
382...06	5F.06T15P	5,50	T15PQ	DT15PK
382...08	5F.08T20P	5,50	T20PQ	DT20PK
382...10/12/14	5.10T20P	6,50	T20PQ	DT20PK / DT20PQ
383...06	5F.06T15P	5,50	T15PQ	DT15PK
383...08	5F.08T20P	5,50	T20PQ	DT20PK
383...10/12	5.10T20P	6,50	T20PQ	DT20PK / DT20PQ
ABS	5.12T20P	6,50	T20PQ	DT20PK / DT20PQ
ADR.01...	C009000	0,75	T6W	DT6K
ADR.02/03...	C009001	1,50	T8L	DT8K
ADR.04/05/06...	C009002	1,50	T8L	DT8K
B105/BKT105	6.075T15P	5,00	T15PQ	DT15PK
B110/BKT110	6.075T15P	5,00	T15PQ	DT15PK
BKT356	5.12T20P	6,50	T20PQ	DT20PK / DT20PQ
DAH	5.12T20P	6,50	T20PQ	DT20PK / DT20PQ
DAH.M.25.012...	030.2547.T8P	1,30	T8PL	DT8PK
DAH.M.25	030.2553.T8P	1,30	T8PL	DT8PK
DAH.M.37	030.3070.T10P	3,40	T10PL	DT10PK
DAH.M.62	5.12T20P	6,50	T20PQ	DT20PK / DT20PQ
DAM31...02B	030.2541.T8P	1,10	T8PL	DT8PK
DAM31...03A/B	030.2547.T8P	1,10	T8PL	DT8PK
DAM31...04A/B	030.2553.T8P	1,10	T8PL	DT8PK
DAM31...05A/B	030.2557.T8P	1,10	T8PL	DT8PK
DAM32...A...	030.3576.T10P	3,50	T10PL	DT10PK
DAM32...02A/B	030.3562.T10P	3,50	T10PL	DT10PK
DAM32.025.D...03A/B	030.3569.T10P	3,50	T10PL	DT10PK
DAM32.032.D...03A/B	030.3576.T10P	3,50	T10PL	DT10PK
DAM32.417...03B	030.3569.T10P	3,50	T10PL	DT10PK
DAM62	030.3070.T10P	3,00	T10PL	DT10PK
DRHD	6.075T15P	5,00	T15PQ	DT15PK
HSK	5.12T20P	6,50	T20PQ	DT20PK / DT20PQ
L381.A060...	5F.08T20P	5,50	T20PQ	DT20PK

Anzugsmomente

Torque of Screws



Typ Type	Schraube Screw	M_d Nm	Schlüssel Clamping wrench	Klinge Blade
L381.D080...	5F.08T20P	5,50	T20PQ	DT20PK
L381.D086...	5.12T20P	6,50	T20PQ	DT20PK / DT20PQ
L381.G070...	5.10T20P	6,50	T20PQ	DT20PK / DT20PQ
L381.G080...	5F.08T20P	5,50	T20PQ	DT20PK
L381.G086/090/098	5.12T20P	6,50	T20PQ	DT20PK / DT20PQ
L381.N090...	5F.08T20P	5,50	T20PQ	DT20PK
L381.S...	5.15T20P	6,50	T20PQ	DT20PK / DT20PQ
L381.T...	5F.08T20P	5,50	T20PQ	DT20PK
L381.X090...	5.12T20P	6,50	T20PQ	DT20PK / DT20PQ
M101	030.3543.T8P	2,00	T8PL	DT8PK
M101...A22...30/...40	030.0520.0912	6,50	T15PQ	DT15PK
M101...A32...30/...40	030.0620.0913	8,00	T20PQ	DT20PK / DT20PQ
M101...A40...30/...40	030.1030.0911	15,00	SW6,0 DIN911	
M116	5.13T20EP	6,50	T20PQ	DT20PK / DT20PQ
M117K...05	030.265P.0821	1,20	T8PL	DT8PK
M117K...07	030.265P.0819	1,20	T8PL	DT8PK
M117K...09	030.400P.0227	4,30	T15PQ	DT15PK
M117.MD10...	030.400P.0227	4,30	T15PQ	DT15PK
M117U...05	030.265P.0818	1,20	T8PL	DT8PK
M117U...07	2.6.5T8EP	1,20	T8PL	DT8PK
M117P...05	030.265P.0818	1,20	T8PL	DT8PK
M117P...07	2.6.5T8EP	1,20	T8PL	DT8PK
M271	030.2609.T8P	1,20	T8PL	DT8PK
M274	030.3513.T15P	3,00	T15PQ	DT15PK
M275	3.5.10T10P	3,00	T10PL	DT10PK
M275.D	030.357P.0315	3,00	T10PL	DT10PK
M275.T	3.5.10T10P	3,00	T10PL	DT10PK
M279	030.0516.T20P	6,50	T20PQ	DT20PK / DT20PQ
M304	1.8.4T6EP	0,90	T6PL	DT6K
M306	2.6.5T8EP	1,20	T8PL	DT8PK
M308	3.5.12T10EP	3,00	T10PL	DT10PK
M310...03	030.0324.T7P	1,20	T7PL	DT7PK
M310...04	030.3535.T8P	2,00	T8PL	DT8PK
M310...05	030.3543.T8P	2,00	T8PL	DT8PK
M311	4.14T15P	5,00	T15PQ	DT15PK
M311.0016.00.B/E	4.16T15KP	5,00	T15PQ	DT15PK
M313	5.14T20P	6,50	T20PQ	DT20PK / DT20PQ
M313.0016.00.A/B/E	5.13T20KP	6,50	T20PQ	DT20PK / DT20PQ

Typ Type	Schraube Screw	M_d Nm	Schlüssel Clamping wrench	Klinge Blade
M328	5.14T20P	6,50	T20PQ	DT20PK / DT20PQ
M328.0020.00.A/B/E	5.13T20KP	6,50	T20PQ	DT20PK / DT20PQ
M328.0020.D...	5.17T20P	6,50	T20PQ	DT20PK / DT20PQ
M332	5.17T20P	6,50	T20PQ	DT20PK / DT20PQ
M335	6.17T25P	12,00	T25PQ	DT20PQ
M406...02/03	030.2669.T8P	1,20	T8PL	DT8PK
M406...04/05/06	030.2608.T8P	1,20	T8PL	DT8PK
M406.025.11.D16.1.02.B	030.2608.T8P	1,20	T8PL	DT8PK
M409	030.3511.T10P	3,50	T10PL	DT10PK
M610	030.3513.T15P	3,50	T15Q	DT15K
M620	5.14T20P	6,50	T20PQ	DT20PK / DT20PQ
MDR.01...	C009000	0,75	T6W	DT6K
MDR.02/03...	C009001	1,50	T8L	DT8K
MDR.04/05/06...	C009002	1,50	T8L	DT8K
MDR.08/09/10...	C009004	3,50	T15Q	DT15K
R381.T...	5F.08T20P	6,50	T20PQ	DT20PK / DT20PQ
R381.X073...	5F.08T20P	6,50	T20PQ	DT20PK / DT20PQ
R381.X090...	5.12T20P	6,50	T20PQ	DT20PK / DT20PQ
SM328	5.17T20P	6,50	T20PQ	DT20PK / DT20PQ

Vorschubwerte und Zeitberechnung

Feed rates and time calculation

Einfach und problemlos lässt sich dies mit dem Rechenprogramm HCT bewältigen. Wir empfehlen, die Schnittdaten mit diesem Programm zu ermitteln, weil nur so die hohe Zerspanungsleistung und Standzeit der HORN-Zirkularfräser erreicht werden kann. Grundlagen der Berechnung finden Sie auf den nachfolgenden Seiten dargestellt.

It is simple and easy to calculate your speed and feeds using HORN'S HCT programme. We recommend that you calculate the cutting data with this programme as, it will provide you with the best cutting performance and results. Basic features of the calculations can be found on the following pages.

Grundlegende Hinweise:

Basic recommendations:

Auskraglänge des Fräsers

Overhang of the milling cutter

Wählen Sie die Aufnahmen oder die Fräserschäfte so kurz wie möglich und prüfen Sie den Rund- und Planlauf der Werkzeuge. Große Schnittbreiten kombiniert mit hoher Auskraglänge erfordern oftmals technische Maßnahmen wie Schnittaufteilung, um das gewünschte Fräsergebnis zu erreichen.

Select the shortest possible clamping device and milling shank, to control the runout tolerance of the tools. Large cutting widths in combination with long overhangs require specific manufacturing methods such as dividing the cutting width to achieve the best possible cutting result due to reduced cutting forces.

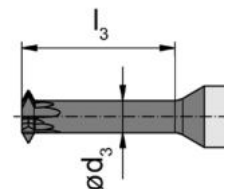

Durchmesser des Fräsers

Diameter of the milling cutter

Rechnerisch ergeben sich dem Bohrungsdurchmesser angenäherte Fräserdurchmesser, die kleinste Fräsermittelpunktsbahn, damit extrem hohe Vorschübe und kurze Bearbeitungszeiten realisiert werden können. Oftmals wird aber der Durchmesser von den Werkstückgegebenheiten bestimmt.

When using a large diameter cutter, whose relationship is close to the bore diameter, manufacturing cycle time can be reduced, due to the smaller centre of rotation and higher feed rates could be realized. Many times the rotation of the milling cutter centre will be defined by the parameters of the workpiece and the whole application setup.

Gewindefräsen

Thread milling

Mit HORN-Zirkulargewindefräsern werden bei voller Frästiefe die Gewindegänge einzeln abgefahren. Dabei ergeben sich Gewinde mit hoher Zylindrizität, besonders in hochfesten Werkstoffen. In Sacklochbohrungen empfiehlt es sich vom Bohrungsgrund nach außen zu arbeiten. Damit vermeidet man das Auffahren auf Späne und vermindert die Gefahr der Beschädigung des Werkzeugs.

Als Faustformel beim Gewindefräsen gilt:

Das Werkzeug darf nicht größer sein als 70% des Kerndurchmessers, ansonsten schneidet das Werkzeug in den Gewindegängen nach.

With HORN thread milling inserts, the thread profile is generated in one full cut to the profile depth of the thread. This produces threads with minimal taper, especially in high alloyed steels. In blind holes, it is recommended to mill from the bottom to the top. Otherwise, there is the risk of damaging the tool because of milling into chips at the bottom of the blind hole.

A general recommendation for thread milling:

The milling cutter diameter should not exceed 70% of the minor diameter of the thread. Otherwise, recutting of the profile occurs, which could bring the whole thread out of tolerance.

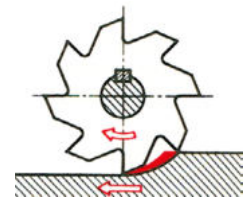

Fräsrichtung

Milling direction

HORN-Zirkularfräswerkzeuge sind rechtsschneidend und es wird empfohlen, wie bei Hartmetall-Werkzeugen üblich, im Gleichlauf zu fräsen.

Most HORN milling tools are right-handed and it is recommended to use them with the climb milling process as this is generally recommended for carbide tools.

Einfahrschleife > 45°
Ramp angle

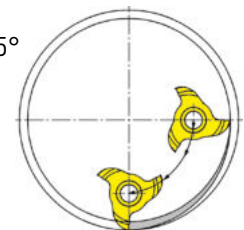

Eintauchen in das Werkstück

Milling entry into the workpiece

Einfaches radiales Eintauchen erregt aufgrund des hohen Umschlingungswinkels oftmals Schwingungen, die sich beim Nutfräsen bis zum Erreichen des Nutgrundes nicht mehr beruhigen. Empfohlen wird deshalb unter 45° bis 180° in einer Einfahrschleife auf Nuttiefe zu fräsen. Die ermittelten Vorschubwerte beziehen sich zwar auf die volle Frästiefe, werden aber auch beim Einfahren beibehalten.

A simple radial entry of the milling cutter creates a very long contact angle which leads to vibrations which will not disappear for the rest of the milling operation and are visual on the bottom of the groove. It is recommended to enter the groove with a ramp angle of 45° up to 180° to the maximum depth of cut. The calculated cutting data refers to the milling condition when the insert is in the full cut, but can be also used for the entry loop.

ISO

a_r	a_e	radiale Schnitttiefe radial depth of cut
d		Schneidkreis-Ø [mm] Cutting edge Ø [mm]
f		Vorschub pro Umdrehung $f = f_z \cdot Z$ [mm/U] [mm/rev] Feed per revolutions
f_z	s_z	Vorschub/Zahn $f_z = \frac{v_f}{Z \cdot n}$ [mm] Feed/tooth
h_m		mittlere Spandicke medium thickness of chip
n		Drehzahl $n = \frac{v_c \cdot 1000}{d \cdot \pi}$ [1/min] Revolutions
r		Radius Fräser Radius of cutter
R		Radius Werkstück Radius of workpiece
v_c		Schnittgeschwindigkeit $v_c = \frac{d \cdot \pi \cdot n}{1000}$ [m/min] Cutting speed
v_f	s'	Vorschubgeschwindigkeit $v_f = f_z \cdot Z \cdot n$ [mm/min] Feed rate
v_{f2}	s'_2	Vorschubgeschwindigkeit der Schneide (Nutgrund-Ø) Feed rate of tool tip
v_{f3}	s'_1	Vorschubgeschwindigkeit der Fräsmittelpunktsbahn Feed rate of tool centre
Z		Zähnezahl Number of teeth

Werkstoff Material		Materialgruppe Material group	Härte (HB) Hardness Brinell	Zug- festigkeit R_m [N/mm ²] Tensile Strength	Beispiel Werkstoff Example Material	K10	TA4_	
P	unlegierter Stahl Carbon steel	~ 0,2 % C	P1.1	125	430	CK15		180-140
		~ 0,4% C gegläht annealed	P1.2	190	610	19Mn6		180-140
		~ 0,4% C vergütet quenched	P1.3	210	640	36Mn5		180-140
		~ 0,6% C gegläht annealed	P1.4	190	610	C55		180-140
		~ 0,6% C vergütet quenched	P1.5	300	1000	CK60		180-140
		Automatenstahl Free cutting steel	P1.6	220	750	9SMn28		
	niedrig legierter Stahl (<5%) Alloyed steel	geglüht annealed	P2.1	180	590	100Cr6		
		vergütet quenched	P2.2	280	960	14NiCr10		
		vergütet quenched	P2.3	350	1250	34CrMo4		
		vergütet quenched	P2.4	430	1450	55Cr3		
	hochlegierter Stahl (>5%) high alloyed steel	geglüht annealed	P3.1	200	680	X10CrAl18		
		gehärtet hardened	P3.2	350	1200	X210Cr2		
	Stahlguss Cast steel	unlegiert unalloyed	P4.1	180	590	GE200		
		legiert alloyed	P4.2	220	750	GX40CrSi28		
	Sinterstahl Sintered steel	weich soft	P5.1	220	570	Sint-D39		
M	Rostfreier Stahl Stainless steel	martensitisch ferritisch martensitic ferritic	M1.1	200	680	X16Cr13		
		austenitisch austenitic ferritic	M1.2	300	1000	X6CrNiMo- Ti17-12-2		
		austenitisch ferritisch austenitic	M1.3	230	780	X2CrNiMo- N17-13-3		
H	Gehärtete Stähle Hardened steels	50-55 HRC	H1.1	-	-			
		55-60 HRC	H1.2	-	-			
		60-63 HRC	H1.3	-	-			
		> 63HRC	H1.4	-	-			

Werkstoff Material		Materialgruppe Material group	Härte (HB) Hardness Brinell	Zug- festigkeit R_m [N/mm ²] Tensile Strength	Beispiel Werkstoff Example Material			
						K10	TA4_	
K	Grauguss Grey cast iron	niedrige Festigkeit low tensile strength	K1.1	180	250	GG-25		160-140
		hohe Festigkeit high tensile strength	K1.2	250	350	GG-40		160-140
	Kugelgraphit- guss Spheroidal graphite cast iron	ferritisch ferritic	K2.1	160	400	GGG-40		160-140
		perlitisch perlitic	K2.1	260	700	GGG-60		160-140
	Temperguss Malleable cast iron	ferritisch ferritic	K3.1	200	400	GTW-45		
		perlitisch perlitic	K3.2	260	700	GTS-55-04		
	Ausferritisches Gusseisen / ADI Ausferritic spheroidal cast iron / ADI	vergütet quenched	K4.1	260	800			
		vergütet quenched	K4.2	350	1050			
		vergütet quenched	K4.3	450	1400			
N	Al-Legierungen Al-alloys	nicht vergütbar not heat treatable	N1.1	30		AlMg1		1200-500
		vergütbar heat treatable	N1.2	100	340	AlMgSi1		1200-500
	Al-Guss- Legierung Al-cast-alloy	< 6% Si	N2.1	80	300	AlMgSi6	600-350	1200-500
		6-10% Si	N2.2	100	320	AlSi7Mg	600-350	1200-500
		10-15 % Si	N2.3	130	450	AlSi12		1200-500
	Kupfer- Legierungen Copper-alloys	Reinkupfer Pure copper	N3.1	100	340	Cu	230-180	1200-500
		Messing, Bronze Brass	N3.2	90	310	CuZn40Pb	230-180	1200-500
		Messing bleifrei Lead-free brass	N3.3	110	430	CuZn40	230-180	1200-500
		hochfest high strength	N3.4	300	1000	CuZn25Al5- Mn4Fe3	230-180	1200-500
	Graphit Graphite		N4.1					
S	Warmfeste Legierung (Fe) Heat resistant alloy	geglüht annealed	S1.1	200	670			30-25
		gehärtet hardened	S1.2	275	930			30-25
	Warmfeste Legierung (Ni, Co) Heat resistant alloy	geglüht annealed	S2.1	250	840	Inconel 600		30-25
		gehärtet hardened	S2.2	350	1200	Inconel 713		30-25

Schnittdaten 406/409/DA/DAH/610

Cutting Data



N

Schnittgeschwindigkeit vc (m/min) / Startwerte
Cutting speed vc (m/min) / Start values

	AS4_	SA4_	SD6_	SC6_	IG3_ IG6_	NE2_	HD05	PD75		
	300-220	180-140	300-220	300-220	200-160					
	260-220	160-140	260-220	260-220	180-160					
	260-220	160-140	260-220	260-220	180-160					
	260-220	160-140	260-220	260-220	180-160					
	1000-350	1200-500					3000-500	3000-500		
	1000-350	1200-500					3000-500	3000-500		
	1000-350	1200-500				3000-500	3000-500	3000-500		
		1200-500				2000-500	3000-500	3000-500		
		1200-500				1500-350	3000-500	3000-500		
		1200-500				300-220	3000-500	3000-500		
		1200-500				230-180	3000-500	3000-500		
		1200-500				240-180	3000-500	3000-500		
		1000-500				250-160	3000-500	3000-500		
		70-30		80-30	80-30					
		70-30		80-30	80-30					
		70-30		80-30	80-30					
		70-30		80-30	80-30					

Werkstoff Material		Materialgruppe Material group	Härte (HB) Hardness Brinell	Zug- festigkeit R_m [N/mm ²] Tensile Strength	Beispiel Werkstoff Example Material	K10	TA4_	
S	Titan	Titanlegierung α Titanium alloy α	S3.1	120	240			30-25
		Titanlegierung α - β Titanium alloy α - β	S3.2	360	1200			30-25
		Titanlegierung β Titanium alloy β	S3.3	410	1400			30-25
O	Thermoplaste Thermoplastics		01.1			1500-500		
	Duroplaste Duro plaste		01.2			1500-500		
	Kunststoffe glasfaser- verstärkt Plastics glass fibre reinforced	GFK	01.3					
	Kunststoffe kohlefaser- verstärkt Plastics carbon fibre reinforced	CKF	01.4					

Schnittdaten 406/409/DA/DAH/610

Cutting Data



N

Schnittgeschwindigkeit v_c (m/min) / Startwerte
Cutting speed v_c (m/min) / Start values

AS4_	SA4_	SD6_	SC6_	IG3_ IG6_	NE2_	HD05	PD75		
	70-30		80-30	80-30					
	70-30		80-30	80-30					
	70-30		80-30	80-30					
					500-1500				
					500-1500				

Schneidstoff Material group	Schichtaufbau Coating structure	Empfehlung Recommendation						Anwendung Application
AN2_ AN4_	AlCrSiN	P05	M05	K05	N05	S05	H05	Bei hohen Schnittgeschwindigkeiten geeignet für Trockenbearbeitung Nut- und Trennfräsen For high cutting speeds, suitable for dry machining, groove and slot milling
		P10	M10	K10	N10	S10	H10	
		P20	M20	K20	N20	S20	H20	
		P30	M30	K30	N30	S30	H30	
		P40	M40	K40	N40			
		P50	M50					
AS4_ AS6_	TiAlN	P05	M05	K05	N05	S05	H05	Ideal für Schruppbearbeitungen, Allrounder auch geeignet für Trocken- bearbeitung Nut- und Trennfräsen Ideal for roughing operations, All-rounder also suitable for dry machining, groove and slot milling
		P10	M10	K10	N10	S10	H10	
		P20	M20	K20	N20	S20	H20	
		P30	M30	K30	N30	S30	H30	
		P40	M40	K40	N40			
		P50	M50					
DD2_		P05	M05	K05	N05	S05	H05	Schruppen und Schlichten Roughing and finishing
		P10	M10	K10	N10	S10	H10	
		P20	M20	K20	N20	S20	H20	
		P30	M30	K30	N30	S30	H30	
		P40	M40	K40	N40			
		P50	M50					
EG3_	AlTiN + TiN	P05	M05	K05	N05	S05	H05	Ideal für Schlichtbearbeitungen bei hohen Schnittgeschwindigkeiten Ideal for finishing operations at high cutting speeds
		P10	M10	K10	N10	S10	H10	
		P20	M20	K20	N20	S20	H20	
		P30	M30	K30	N30	S30	H30	
		P40	M40	K40	N40			
		P50	M50					
EG5_	AlTiN + TiN	P05	M05	K05	N05	S05	H05	Ideal für Schruppbearbeitungen bei hohen Schnittgeschwindigkeiten Nut- und Trennfräsen Ideal for roughing operations at high cutting speeds, groove and slot milling
		P10	M10	K10	N10	S10	H10	
		P20	M20	K20	N20	S20	H20	
		P30	M30	K30	N30	S30	H30	
		P40	M40	K40	N40			
		P50	M50					
IG3_	TiAlSiN	P05	M05	K05	N05	S05	H05	Ideal für Schlichtbearbeitungen bei hohen Schnittgeschwindigkeiten Nut- und Trennfräsen Ideal for finishing operations at high cutting speeds, groove and slot milling
		P10	M10	K10	N10	S10	H10	
		P20	M20	K20	N20	S20	H20	
		P30	M30	K30	N30	S30	H30	
		P40	M40	K40	N40			
		P50	M50					
IG6_	TiAlSiN	P05	M05	K05	N05	S05	H05	Ideal für Schruppbearbeitungen bei hohen Schnittgeschwindigkeiten Nut- und Trennfräsen Ideal for roughing operations at high cutting speeds, groove and slot milling
		P10	M10	K10	N10	S10	H10	
		P20	M20	K20	N20	S20	H20	
		P30	M30	K30	N30	S30	H30	
		P40	M40	K40	N40			
		P50	M50					
NE2_	ta-C	P05	M05	K05	N05	S05	H05	Schruppen und Schlichten Roughing and finishing
		P10	M10	K10	N10	S10	H10	
		P20	M20	K20	N20	S20	H20	
		P30	M30	K30	N30	S30	H30	
		P40	M40	K40	N40			
		P50	M50					

Beschichtungsübersicht

Coating Overview



Schneidstoff Material group	Schichtaufbau Coating structure	Empfehlung Recommendation						Anwendung Application
		P05	M05	K05	N05	S05	H05	
RC2_ RC4_	AlCrSiN	P05	M05	K05	N05	S05	H05	bei hohen Schnittgeschwindigkeiten geeignet für Trockenbearbeitung Nut- und Trennfräsen
		P10	M10	K10	N10	S10	H10	
		P20	M20	K20	N20	S20	H20	at high cutting speeds suitable for dry machining Groove and parting milling
		P30	M30	K30	N30	S30	H30	
		P40	M40	K40	N40			
		P50	M50					
SG3_	TiAlCrSiN	P05	M05	K05	N05	S05	H05	Schruppen und Schlichten
		P10	M10	K10	N10	S10	H10	
		P20	M20	K20	N20	S20	H20	Roughing and finishing
		P30	M30	K30	N30	S30	H30	
		P40	M40	K40	N40			
		P50	M50					
TI2_	TiCn	P05	M05	K05	N05	S05	H05	Schruppen und Schlichten bei moderaten Schnittgeschwindigkeiten, Reduzierung von Aufbauschneiden
		P10	M10	K10	N10	S10	H10	
		P20	M20	K20	N20	S20	H20	Roughing and finishing at moderate cutting speeds, reduction of built-up edges
		P30	M30	K30	N30	S30	H30	
		P40	M40	K40	N40			
		P50	M50					
TN3_	TiN	P05	M05	K05	N05	S05	H05	Schruppen und Schlichten bei moderaten Schnittgeschwindigkeiten Nut- und Trennfräsen
		P10	M10	K10	N10	S10	H10	
		P20	M20	K20	N20	S20	H20	Roughing and finishing at moderate cutting speeds, groove and slot milling
		P30	M30	K30	N30	S30	H30	
		P40	M40	K40	N40			
		P50	M50					
SA4_ SA6_		P05	M05	K05	N05	S05	H05	Schruppen und Schlichten bei mittleren Schnittgeschwindigkeiten, ideal bei hohen Vorschüben
		P10	M10	K10	N10	S10	H10	
		P20	M20	K20	N20	S20	H20	Roughing and finishing at medium cutting speeds, ideal for high feed rates
		P30	M30	K30	N30	S30	H30	
		P40	M40	K40	N40			
		P50	M50					
SC6_	TiCN + Al2O3	P05	M05	K05	N05	S05	H05	Ideal für Schruppbearbeitungen bei hohen Schnittgeschwindigkeiten
		P10	M10	K10	N10	S10	H10	
		P20	M20	K20	N20	S20	H20	Ideal for roughing operations at high cutting speeds
		P30	M30	K30	N30	S30	H30	
		P40	M40	K40	N40			
		P50	M50					

ISO 513		P	M	K	N	S	H
+ Zähigkeit / Tenacity - Verschleißfestigkeit / Wear resistance +	05	05	05	05	05	05	05
	10	10	10	10	10	10	10
	20	20	20	20	20	20	20
	30	30	30	30	30	30	30
	40	40	40	40	40		
	50	50					

Typ Type	Seite Page
108	45-49, 288
111	74-78, 300, 301
116	113-115
304	32-35, 280-282
306	50-59
306	289-291
308	79-85, 302
311	97-103, 310-312, 413, 414
313	126-128, 130-136, 321-323, 419
314	229-231, 257-260, 353, 456
325	160
328	161-167, 331, 332, 423
332	184-187,
335	203
380	221-224, 351, 352
380...IK	223, 225
381	228
381	442-454
382	250-253
383	254-256
406	430, 531, 532
409	431, 549-551
606	60-65
606	292-294
608	86-87,
608	303-305
610	562
611	104-107
611	313, 614
613	137-146,
613	324, 325, 373-376
620	207, 208
628	168-174, 333, 334, 377
632	188-191, 340, 378, 379
636	192-194
713	147, 148
911	108
913	149
928	175
932	195
939	196-198
ABS..380	227
DA31	482
DA32	483-485
DA62	486
DAH25	497
DAH37	503-504
DAH82	510
DAH84	512
DAH25	494-496
DAH37	500-502
DAH82	507-509
DAH84	511
DAM31	469-470, 468, 475, 476
DAM32	468, 471, 473, 475, 476
DAM62	472, 474, 477
DCF	22
DCG	13-18

Typ Type	Seite Page
DCN	20
DCR	19
DCX	21
DGVZ	404
HSK380	226
L313	129, 133
M101	235-239
M116	112
M275	211-214, 345-346, 436, 437
M279	380
M304	30, 279
M304.ST	31
M306	38-40, 287
M306.ER	41
M306.M	44
M306.ST	42
M308	68-69, 299
M308.ER	71
M308.M	73
M308.ST	70
M310	264-270
M310	270
M311	90-91, 94, 309, 412
M311.ER	93
M311.M	96
M311.ST	92
M313	118, 123, 319, 320, 418
M313.ER	121, 122
M313.M	125
M313.ST	119, 120
M328	152-153, 157, 329, 422
M328.ER	155, 156
M328.M	159
M328.ST	154
M332	178-179, 339
M332.ER	181
M332.M	183
M332.ST	180
M335	202
M406	428, 526-530
M409	429, 536-548
M610	560-561
M620	206
MD	478-481
MDR	390
N105	385
N110	385
N314	455
314	455
RS275	218, 347
RS279	381, 382
S101	240-244
S117	385
S275	215-217, 438
S310	271
SDA62	487
SM328	330
WFB	43, 72, 95, 124, 158, 182



**FINDEN SIE JETZT IHRE
PASSENDE WERKZEUGLÖSUNG.**

FIND YOUR RIGHT
TOOLING SOLUTION NOW.

horn-group.com

DEUTSCHLAND, STAMMSITZ

GERMANY, HEADQUARTERS

—

Hartmetall Werkzeugfabrik

Paul Horn GmbH

Horn-Straße 1

72072 Tübingen

Tel. +49 7071 7004-0

Fax +49 7071 72893

info@de.horn-group.com

horn-group.com